

# FORMAX<sup>®</sup>

---

## Cut-True 27S Semi-Automatic Electric Paper Cutter

S/N 890190 and above

OPERATOR MANUAL  
Rev. 4



# TABLE OF CONTENTS

TOPIC	PAGE #
SPECIFICATIONS	1
SAFETY GUIDELINES	1
UNPACKING	1
STAND ASSEMBLY & INSTALLATION	2
OVERVIEW	3 - 4
ATTACHING SIDE TABLES	4
OPERATION	5
TROUBLESHOOTING	6
MAINTENANCE & LUBRICATION	6
RECALIBRATING BACK GAUGE AND LED DISPLAY	7
ERROR MESSAGES	8
CHANGING THE CUTTING STICK	8
BLADE MAINTENANCE	9
BLADE REPLACEMENT	9 - 12

## SPECIFICATIONS

Cutting Action	Dual-button electric
Maximum Cutting Width	Up to 18.9"
Maximum Paper Stack Height	Up to 3.15"
Cutting Length Behind Blade	19.87"
Table Size in Front of Blade	12.37"
Narrow Cut	1.89"
Table Size	32" W x 37" D
LED Cutting Line	Yes
Clamp Style	Automatic
Back Gauge Adjustment	Manual crank
Back Gauge Reading	LED digital display, inches/metric
Blade Change Safety Tool	Included
Dimensions	51" H x 36" W x 39" D
Weight	550 lbs.
Power Supply	110V, 20A dedicated line
Safety Certifications	CE approved, UL pending



## SAFETY GUIDELINES

- \* Operators should read this manual prior to using the cutter.
- \* The Cut-True 27S should only be used by one person at a time.
- \* Keep hands away from the cutting area. The cutter is operated by pressing two "enable switches" simultaneously.
- \* Do not disassemble Plexiglas safety covers, and never attempt to change the settings of any protective devices.
- \* Do not grasp underneath the blade edge.
- \* When changing the blade, carefully follow the instructions in this manual, and be sure to use the supplied Blade Change Safety Tool. Wear leather gloves to provide additional safety.
- \* The Cut-True 27S is designed to cut only paper. DO NOT attempt to cut non-paper materials including metal sheets, wood, plastic or anything other than paper. Machine damage and/or personal injury may occur.
- \* Be sure to check the safety devices before each operating session.

## UNPACKING

The side panels, wooden paper pusher, blade safety device, and back gauge crank with screw are packed separately in the box with the machine. Please set these aside and install after connecting the cutter to the stand.

The cutter should be installed in a location with sufficient space to permit efficient assembly, operation and maintenance. Do not install in locations with direct sunlight or near a heat source.

# STAND ASSEMBLY & INSTALLATION

Please use caution when moving the cutter, and be sure to utilize appropriate lifting devices when attaching to the stand.

Assemble the stand using the following steps:

1.	Set the legs so the 4 threaded pins point upward.
2.	Assemble the crossbars of the stand so the color labels on each match the corresponding legs. Fasten stand securely with hexagonal screws.
3.	Place the chassis correctly onto the assembled stand.
4.	Tighten the four hexagonal nuts.
5.	Position stand shelf in place and fasten securely with enclosed screws.

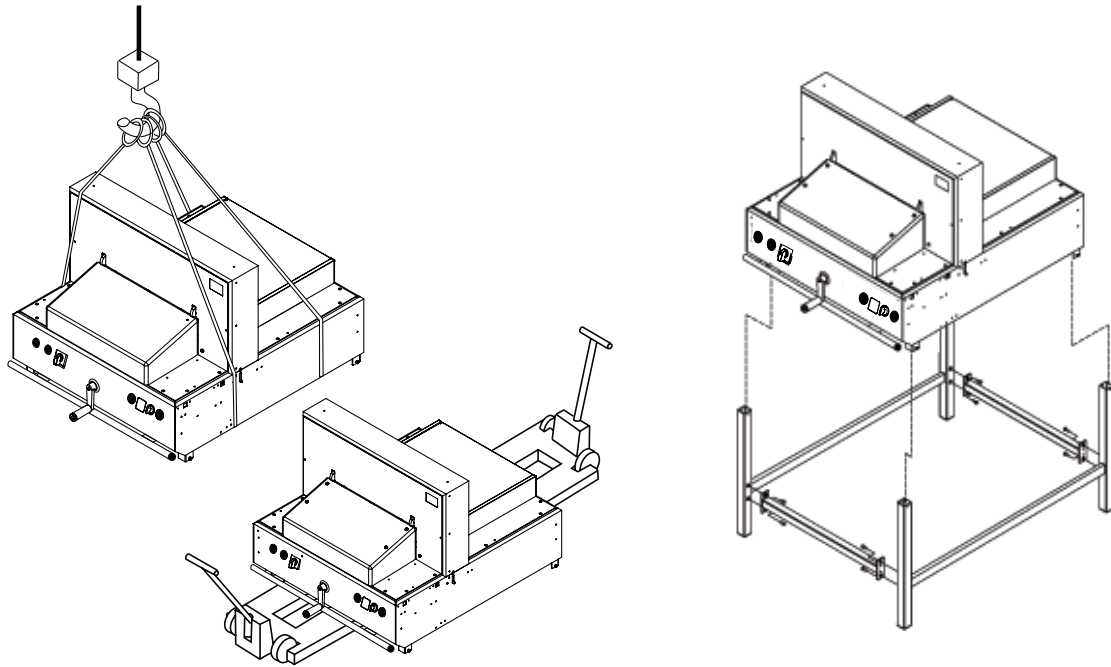

The cutter can be moved by using an overhead motorized lift, pallet jacks, or by hand.

**NOTE:** Four people are required to move the cutter by hand.

To move the cutter by hand, utilize the lifting handles located on the front and back of the machine. To adjust the handles, loosen the knobs on the underside and slide the handles to out to a comfortable position. Retighten the knobs.

When the cutter is in place and securely attached to the stand, loosen the knobs, adjust the handles to their storage position and tighten the knobs.



Lifting handle



Adjustment knob

Adjustment knob

Lifting handles

# OVERVIEW

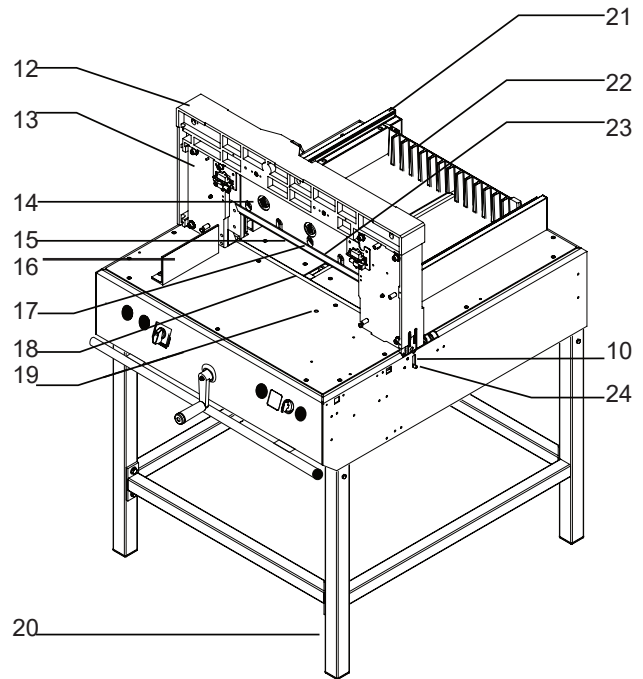
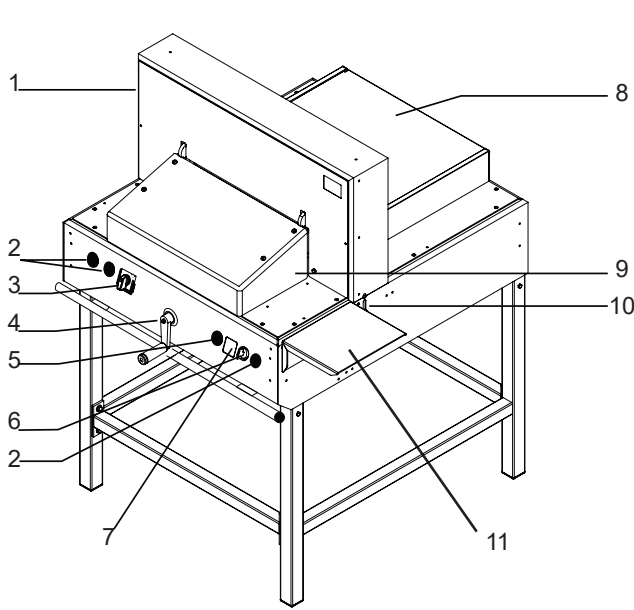

## DESCRIPTION OF PARTS

1.	Cover	Attached to the cutter with four screws. Disassemble only in case of blade change or maintenance.
2.	Enable Switches	These switches must be pushed simultaneously to operate the paper clamp and cutting blade.
3.	Power Switch	Used to turn on and off power to the cutter.
4.	Back Gauge Crank	Used to adjust back gauge to appropriate paper size and cut length. It is indirectly connected with the Back Gauge: to engage the crank, simply push it towards the machine, then turn. To release, pull the crank toward the operator. To move the back gauge toward the operator, turn clockwise. To move the back gauge away from the operator, turn counterclockwise.
5.	Power Light	Shows when machine is powered on.
6.	Key-Activated Mode Select Switch	Turn to right for cutting. Turn to left for blade replacement. Turn to middle to stop all operations.
7.	Digital Measurement Readout	Shows the current position of the back gauge, in mm and inches.
8.	Rear Safety Cover	Clear plexi cover is provided for operator safety and helps to prevent dust buildup.
9.	Front Safety Cover	Prevents operators from placing hands or other objects in the cutting area. Must be in the lowered/closed position in order to operate the cutter. The guard can only be reopened when the blade is in the upright position.
10.	Side Interlock Device A	The cutter will not operate if the 6mm T-wrench used for blade adjustments is still in the adjustment slot.
11.	Side Panel	Additional workspace.
12.	Carrier (support)	Carries the blade holder and the entire mechanism of the machine.
13.	Safety Interlock Device B	The machine can only be operated when the safety guard is closed.
14.	Three Socket Headless Screws	Adjustable screws for even cutting.
15.	Cutting Blade	Made of high-quality carbon steel.
16.	Paper Alignment Bars	Steel side bar helps to align the paper prior to cutting.

17.	Blade Holder	Holds blade in place. There are five screws for blade positioning, (which should be set up and released step-by-step following the blade replacement instructions) and adjusting the blade for even operation.
18.	Cutting Stick	Plastic stick which protects the edge of the blade during cutting. Can be repositioned and used on all four sides before being replaced.
19.	Cutting Stick Access Slot	Insert screwdriver here in order to lift and remove cutting stick.
20.	Stand	Steel stand, assembly required.
21.	Side Gauge with Scale	In mm/cm and inches. The indicator on the back-gauge shows the measurement. Fine adjustment is done via the back gauge crank (4). Minimum adjustment is 0.5mm.
22.	Back Gauge	This is moved by rotating the Back Gauge Crank. Used to move the paper stack into the appropriate cutting position.
23.	LED Laser Cutting Line	Shows operator exactly where the blade will cut the paper stack.
24.	Blade Adjustment Access	The blade height can be adjusted up to 2mm by using the adjustment screw. To lower the blade (+), turn to the left. To raise the blade (-), turn to the right. NOTE: If the blade is adjusted too low, it will cut deeply into the cutting stick, damaging not only the stick but the cutting blade. The optimal blade height is when the last sheet in a stack is cut accurately.
25.	Wooden Push Block (not shown)	Used to help align paper stacks for precise cutting.
26.	Blade Change Safety Tool (not shown)	This device is used to safely remove the blade when it needs to be sharpened or replaced.
27.	Tool Kit	Includes T-wrench and interchangeable bits and sockets, wrench, grease tool, and L shaped blade depth adjustment tool.

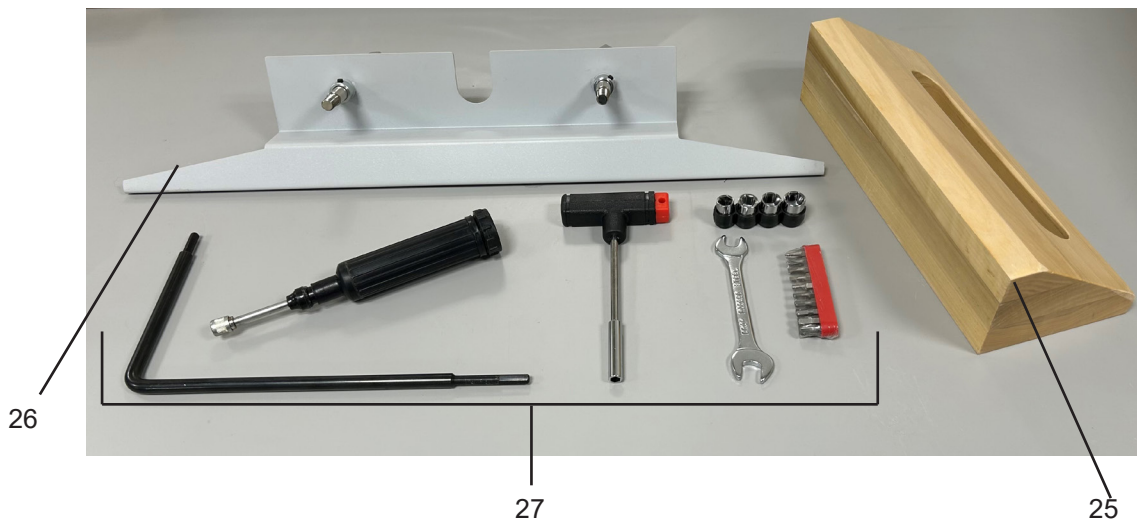

## ATTACHING SIDE TABLES

1. Locate the slots on the right side of the cutter and the tabs on the side table.
2. Align the tabs and the slots and slide downward to attach.
3. Repeat for left side.

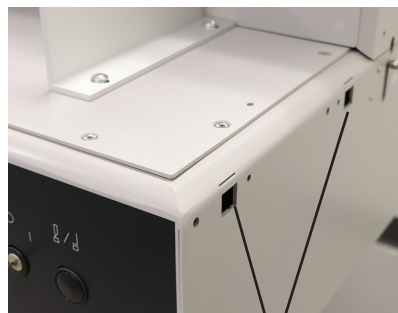

Attachment slots

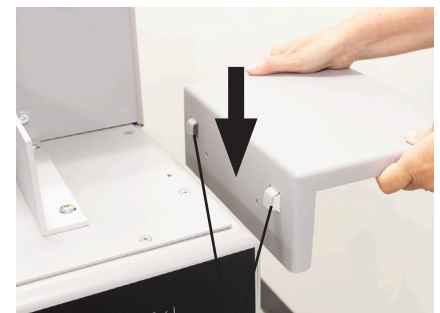

Side table tabs

# OPERATION

1. Turn power on and the LED will display HOME. Push the back gauge crank in and rotate clockwise until the display shows CCW. Now turn the crank counter clockwise to the desired numerical measurement and perform cuts.

**NOTE:** Turning the back gauge after the display shows the CCW message can damage the HOME switch within the Cutter.

**SPECIAL NOTE:** 1.89 inches is the minimum cut that can be performed. Moving the back gauge closer than 1.89 inch will cause the Clamp to come in contact with the back gauge and damage it or jolt it out of square.

Turn the crank counterclockwise to move the back gauge to the correct cutting position based on paper size.

Check the LED display to determine position.

NOTE: The LED display can be set to inches or millimeters. To switch between units, use the red T-wrench or the tip of a pen to push the "Set" button next to the inch/mm LEDs.

NOTE: To prevent the back gauge from moving during paper positioning or cutting, pull the crank slightly toward the operator to disengage it.

2. Open the plexiglass safety cover.
3. Insert paper stack and align with the back gauge and left side guide.

4. The LED cutting line indicates where the blade will cut. Fine tune the position if necessary using the back gauge crank and the LED display.

5. Close the plexiglass safety cover.

NOTE: The blade will not engage if the safety cover is open.

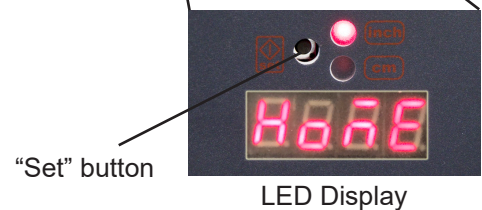

## OPERATION, continued

- Push the 2 operation enable switches simultaneously and hold them until the cutting cycle is complete.



- Open the plexiglass safety cover and remove paper.

**NOTE:** The cutting blade will not engage if the plexiglass safety cover is open.



## TROUBLESHOOTING

PROBLEM:	CHECK THIS:	SOLUTION:
Blade does not move	Check that the power is on.	Be sure power cable is plugged in. Check that the red power switch is turned on.
	Is the plexiglass safety cover fully lowered?	Fully close the safety cover.
	Are both enable buttons being pushed simultaneously?	Be sure cover is closed and press both buttons simultaneously.
Cutter has no power	Check the power source.	Confirm power is reaching the cutter.
	Was the cutter overloaded with too much paper?	Wait until the breaker automatically resets (30-60 seconds). The indicator light will be off. Reduce the size of the paper stack.
Blade is not cutting the last piece of paper in the stack	Does the cutting stick need to be rotated or replaced?	Rotate or replace cutting stick (page 8).
	Is the blade depth adjusted properly?	Adjust blade depth (page 11).
	Does the blade need to be replaced?	Replace blade using blade change safety tool (page 9).

## MAINTENANCE AND LUBRICATION

- Use a dry cloth to wipe surfaces. Do not pour water directly onto the machine. Do not use a brush, acid, or solvents such as benzene, hot water, etc. This will damage the paint.
- All moveable parts need to be lubricated and oiled from time to time. These parts must be cleaned and free of paper dust and oil deposits before lubricating.

# RECALIBRATING BACK GAUGE AND LED DISPLAY

If the number on the LED display does not match the position of the back gauge on the side scale (page 6, #17), or if sheets are not being cut to the correct length, follow the steps below to recalibrate the LED display.

1. Power on the cutter.



Power switch in ON position

2. Turn the back gauge crank clockwise to bring the back gauge to the front, then a few cranks counterclockwise to change the display from HOME to numbers.



3. If the LED display is set to inches, press the "Set" button with the red T-wrench or the tip of a pen for one second to change to centimeters.

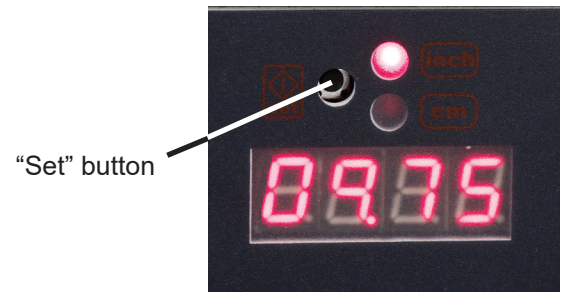

"Set" button

4. Turn the back gauge crank until the side scale position reaches 30cm.



Side scale

Back gauge

5. Press the "Set" button for a few seconds until the LED reads 30.00.
6. Cut one sheet of paper and measure to be sure it is precisely 30cm. If it is the correct length, proceed to step #7.
7. To change the display from centimeters to inches, press the "Set" button for one second. If the back gauge is at 30cm and the display shows 30.00, when you change to inches, it should display 11.81.

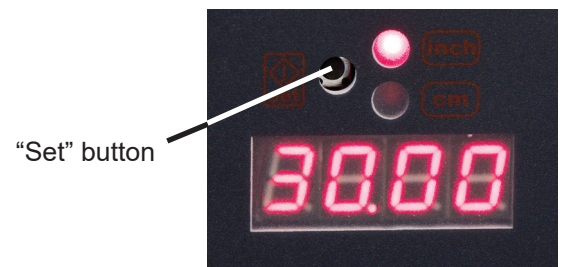

"Set" button

## ERROR MESSAGES

“**CUT.E**” appears in the LED display: the blade has completed 2,000 cutting passes.

Check the blade to see if it is dull or still sharp enough to cut through one sheet of copy paper.

If the blade is still sharp and does not need to be replaced, reset the counter with the following steps:

1. Turn the select switch key to the right.
2. Press and hold the right enable switch for at least 5 seconds, while simultaneously turning the select switch key back to the middle position until the message “CAT” appears in the LED display.
3. Release the right enable switch.

“**E4**” appears in the LED display: Remove the T-wrench from the fine adjustment device.

“**E5**” appears in the LED display: Cutting drive motor is overloaded.

“**E6**” appears in the LED display: The blade couldn't return within the standard period of time after cutting.

## ROTATING / REPLACING THE CUTTING STICK

The cutting stick is the surface the blade contacts during the cutting process. It can be rotated and used on each side, 4 times altogether.

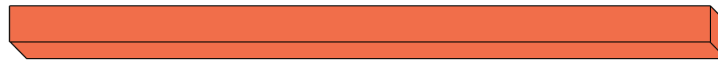

Cutting stick

If the last piece of paper in the stack is not cut through cleanly, and the blade depth has been adjusted properly, the cutting stick should be rotated or replaced.

The cutting stick sits in a channel in the base of the cutter, just below the blade carrier. To remove it, first turn off the power. Then insert the red T-wrench from the tool kit or a small screwdriver into the cutting stick access slot (below left) and press down. Grasp the cutting stick and remove (below right). Rotate the cutting stick to a new side and re-install. If all four sides have been cut, the stick must be replaced.

**NOTE:** When the cutting stick is rotated or replaced, the blade height must be readjusted. See page 13 for blade height adjustment instructions.

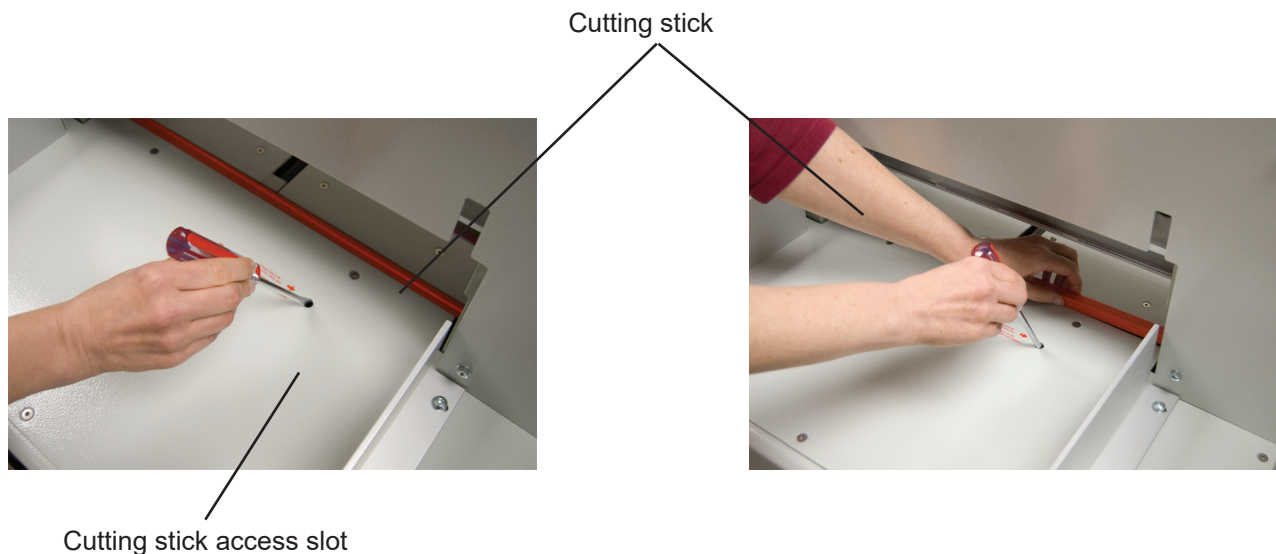

# CUTTING BLADE MAINTENANCE

The cutting blade is made of heat-treated high-carbon steel and is designed for repeated use. However, over time the blade will become dull and not perform to the highest standards. Cutting heavy paper or cardboard will dull the blade more quickly than thinner paper stock. A dull blade will not cut accurately. Blade lifetime with normal copy paper is approximately 1,600 cuts (tested in maximum capacity).

NOTE: If the blade jams in the paper stack or leaves a groove in the paper, it should be changed immediately.

If the blade is not making clean, accurate cuts, check the following:

- \* Have you rotated or replaced the cutting stick? See page 10 for instructions.
- \* Have you correctly adjusted the height of the blade? See page 13 for instructions.

If so, the blade will need to be replaced. The blade can either be re-sharpened by a professional, or it can be replaced with a new blade. To avoid injury, follow the Blade Replacement instructions below using the Blade Change Safety Tool, included with the cutter.

## BLADE REPLACEMENT PROCEDURE

1. Loosen and remove (8) screws from the cover. Remove cover.

Front Cover

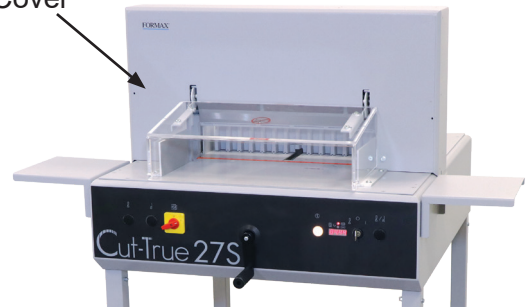

set the key to the blade change position

2. Turn the power switch ON, and turn the select switch to the left.



Power switch ON

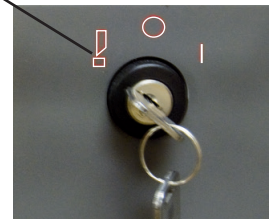

3. Press two enable switches simultaneously to move the blade down to the bottom position.



4. Turn the select switch to the center (OFF) position. Using the T-wrench, remove the far right blade screw (A).

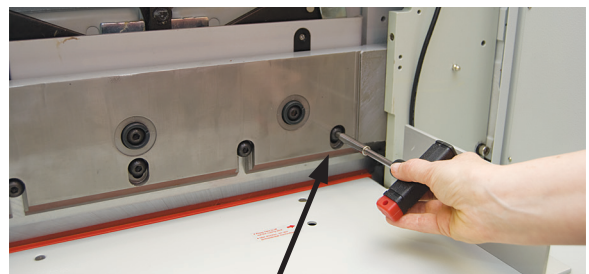

A

5. Turn the select switch to the right. Press the left blade/ clamp activation button to raise the blade. Once fully retracted, turn the select switch to the center (OFF) position and turn the power OFF.

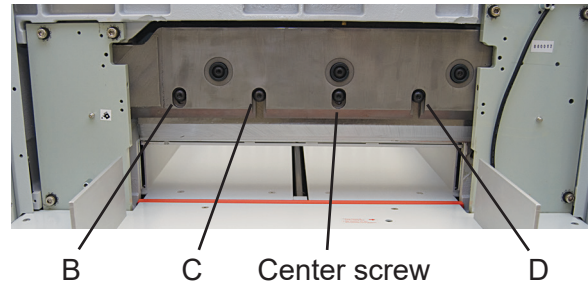

6. Remove the far left screw (B). Remove the screws to the left and right of center (C & D), but leave the center screw in place.  
**NOTE: Do not remove the center screw.**

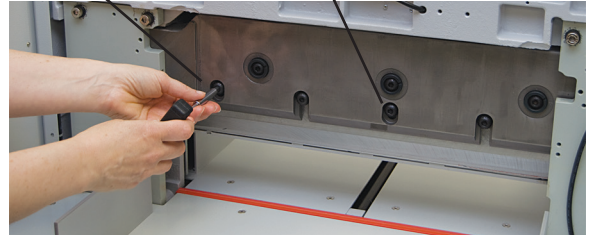

7. Remove the blade change safety tool from the tool box and screw the handles into the two holes to the left and right of center (see photos). Screw them in tightly, to prevent the blade from falling out of the holder.



8. With the blade change safety tool in place, use the T-wrench to remove the center screw.

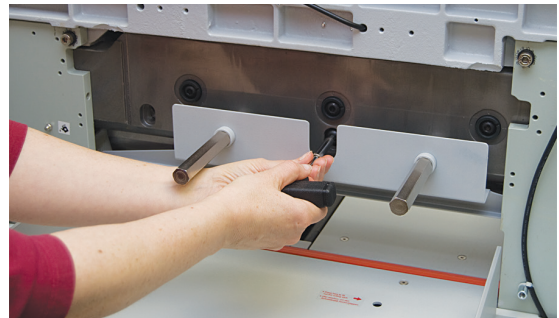

9. Grip and loosen both of the blade change tool handles by turning just a half reverse turn to remove the blade from the machine.

Carefully move the blade and holder downward in order to remove it safely from the machine. **NOTE:** Be careful to avoid injury from the very sharp blade.



10. Carefully remove the old blade from the blade change safety tool. Set it on a flat surface and unscrew the handles. Cap the old blade with a protective pad to prevent injury.

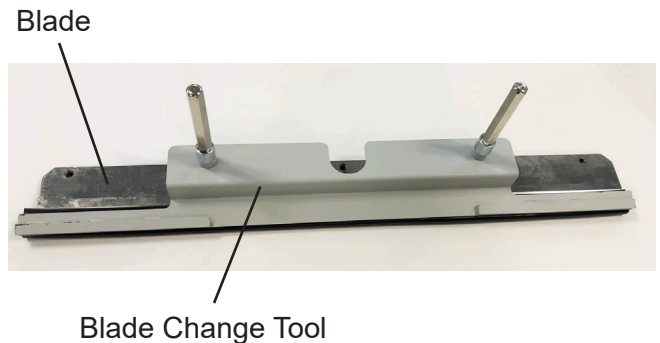

11. Use the T-wrench to turn the three socket headless adjustable screws, and set to "0" point. Turn the blade fine adjustment device clockwise, at the right side of the machine. This ensures the new blade does not cut too deeply into the cutting stick.



12. To access the Blade Adjustment Device, located on the right side of the cutter (Fig. 14a), press down on the silver finger knob, and insert the L-wrench into the adjustment slot.

To move the blade up, turn clockwise.  
To move the blade down, turn counterclockwise.

**NOTE: Be sure to remove the wrench before turning on the power.**



L-shaped wrench



13. Place the new blade with the beveled cutting edge facing up, and the screw holes at the top, as shown here. Remove the protective pad from the new blade.

To attach the blade change tool, place it over the blade and screw the handles into the screw holes.

Reverse the procedure to install the new blade.

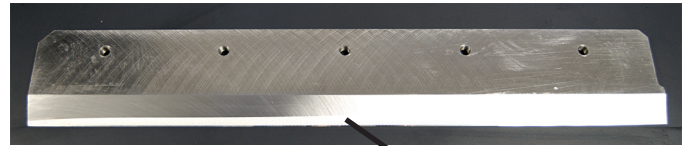

Beveled cutting edge



14. Once the blade screws are all securely in place, check to see if the blade touches the cutting stick evenly. If it is tilted or uneven, adjust the three socket headless screws until the blade and cutting stick match.

Check the cutting depth by turning the Select Switch to the right and cutting a single sheet of paper. If the blade does not cut accurately, adjust the three socket headless screws and the Blade Adjustment Device.



Set key to the cut position

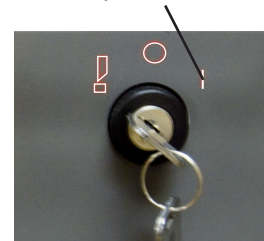

15. Once the blade is properly adjusted, reposition the cover and tighten all screws into place.