

FORMAX[®]

ColorMaxLP2
Digital Color Label Printer

Serial #100048682 and above

SAFETY PRECAUTIONS

THIS EQUIPMENT PRESENTS NO PROBLEM WHEN USED PROPERLY.
OBSERVE SAFETY RULES WHEN OPERATING THE COLORMAXLP2 PRINTER.

BEFORE USING PRINTER, READ THIS MANUAL CAREFULLY AND FOLLOW
RECOMMENDED PROCEDURES, SAFETY WARNINGS, AND INSTRUCTIONS:

- ✓ Keep hands, hair, and clothing clear of rollers and other moving parts.
- ✓ Avoid touching moving parts or materials while machine is in use. Before clearing a jam, be sure machine mechanisms come to a stop.
- ✓ Always turn machine off before making adjustments, cleaning the machine, or performing any maintenance covered in this manual.
- ✓ Power cord and power supply supplied with machine. Plug it into a properly grounded, easily accessible wall outlet near machine. Failure to properly ground machine can result in severe personal injury and/or fire.
- ✓ Power cord and wall plug are primary means of disconnecting machine from power supply.
- ✓ **DO NOT** use an adapter plug on line cord or wall outlet.
- ✓ **DO NOT** remove ground pin from line cord.
- ✓ **DO NOT** route power cord over sharp edges or trap it between furniture.
- ✓ Avoid using wall outlets that are controlled by wall switches or shared with other equipment.
- ✓ Make sure there is no strain on power cord caused by jamming it between equipment, walls or furniture.
- ✓ **DO NOT** remove covers. Covers enclose hazardous parts that should only be accessed by a qualified service representative. Report any cover damage to your service representative.
- ✓ This machine requires periodic maintenance. Contact your authorized service representative for required service schedules.
- ✓ To prevent overheating, do not cover vent openings.
- ✓ Use this equipment only for its intended purpose.

In addition, follow any specific occupational safety and health standards for your workplace or area.

This manual is intended solely for the use and information of Formax, its designated agents, customers, and their employees. The information in this guide was obtained from several different sources that are deemed reliable by all industry standards. To the best of our knowledge, that information is accurate in all respects. However, neither Formax, nor any of its agents or employees shall be responsible for any inaccuracies contained herein.

Memjet® is a registered trademark.

All other trademarks are the property of their respective holders.

All rights reserved. No part of this book may be reproduced or transmitted in any form or by any means, electronic or mechanical, including photocopying, recording, or any information storage and retrieval system, without permission in writing from the publisher.

SECTION 1 – <i>Getting Acquainted</i>	1
Front View	1
Rear View	3
Print Engine View	4
Print Area View (Under Clamshell)	5
Ink Tank Door View	7
Unwinder/Roll Feeder	Error! Bookmark not defined.
Rewinder	Error! Bookmark not defined.
SECTION 2 – <i>Installing Printer</i>	9
Contents of Packaging	9
Unpack and Set-up	10
Choose a Location	9
Remove Shipping Materials	Error! Bookmark not defined.
Install Ink Drip Tray Assembly	11
Install Unwinder/Winder Adapter Plates	Error! Bookmark not defined.
Connect Printer	17
Install Printer Driver	18
Install Over USB Connection	18
Install Over Network Connection, Version A	20
Install Over Network Connection, Version B	23
Install Ink Tanks	25
First Time Install Printhead Cartridge	26
Connect Printer to External Device	29
Load Media	29
Roll-to-Roll Label Printing	30
Roll-to-Cut Label Printing	30
Connect the Unwinder and Winder	30
Unwinder Mode Switch	Error! Bookmark not defined.
Loading Labels	32
Roll-to-Roll Printing	32
Adjusting Speed on Unwinder/Rewinder	Error! Bookmark not defined.
Adjusting Winder Tension	Error! Bookmark not defined.
Roll-to-Cut Labels	34
Printing Fanfold Labels	34
Bleeds	34
SECTION 3 – <i>Operating Printer</i>	35
Printer Driver Properties	35
General Tab	36
Layout Tab	37
Color Tab	37
Media Tab	38
Import/Export Tab	40
Using Printer Touchscreen	41
Drop-Down Menu Options	41
Using Printer Toolbox	52
Drop-Down Menu Options	52
Maintenance Drop-Down	65
Service Drop-Down	65
Test Print Drop-Down	65

TABLE OF CONTENTS

SECTION 4 – <i>Maintenance</i>	66
Replace Ink Tanks	66
Clean Ink Tank Contacts	68
Clean/Replace Printhead Cartridge	69
Inspect the Service Station	74
Replace Ink Waste Tray	75
Cleaning	76
Shipping or Transporting Printer	78
SECTION 5 – <i>Troubleshooting Guide</i>	80
Memjet® Printhead	80
Printer	81
Errors and Warnings	82
Appendices	87
Appendix A – Printer Specifications	87
Appendix B – Supplies and Optional Hardware	88
Appendix C – Borderless Printing: Borderless Print vs. Oversize	89
Index	93
Printer Maintenance Schedule	93

SECTION 1 – *Getting Acquainted*

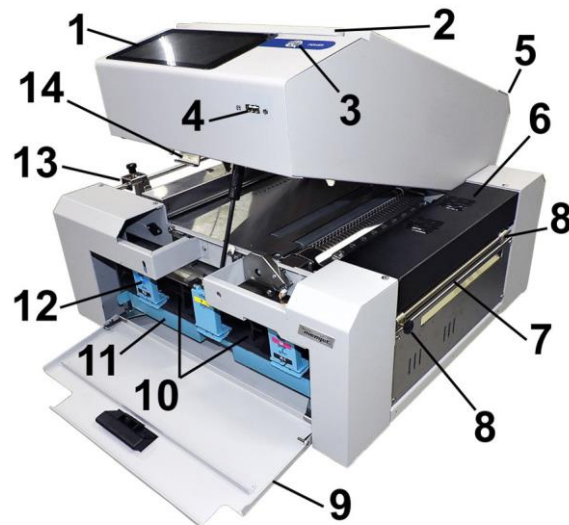

Front View

1.	Control Panel Touchscreen – Displays Menu and information about Printer status. Controls Printer functions and set-up.
2.	Top Cover – Provides access to Print Engine, Printhead and Service Station.
3.	ON/OFF LED Button – Turn power ON or OFF during idle time and maintenance.
4.	Control Panel USB Port – Use a USB thumb drive to back-up Print Jobs in the Printer Job Library and Debug Logs. Upload Print Jobs from other sources and same model printers. Upload MP4 videos and apply Printer firmware (*.fbf) and Touchscreen UI (*.rpz) files.
5.	Clamshell – Holds upper section of Print Engine including Printhead and Service Station. Lifts up to clear media path.
6.	Ink Vapor Exhaust Fan – Draws ink vapor out of the Print Area and away from the Exit Sensor.
7.	Cutter Assembly – Cuts media after each piece or at end of job.
8.	Fixed and Adjustable Exit Media Guides – Loosen and tighten knob to slide Adjustable Exit Guide to accommodate different media widths and keep media aligned as it exits the Printer.
9.	Ink Tank Door – Access to Ink Tanks. When open, disconnects Printer communication to Ink Tanks and allows safe installation and replacement.
10.	Ink Tanks – Printer has five Ink Tanks: Cyan, Yellow, Magenta, and two Black. LP2-21 Cyan, LP2-22 Yellow, LP2-23 Magenta, LP2-24 Black
11.	Ink Waste Tray – Catches any waste ink produced by system. Tray is filled with absorbent material. Pull on tab to remove Tray.
12.	Ink Tank Latches – Used to hold Ink Tanks in slots. NOTE: Make sure both sides at bottom part of latch are engaged.
13.	Adjustable Media Guide – Adjusts to hold media against Media and Alignment Guides.
14.	Clamshell Latch – Release to raise the Printhead Assembly.

SECTION 1
GETTING ACQUAINTED



Rear View



1.	Top Cover – Provides access to Print Engine, Printhead and Service Station.
2.	ON/OFF LED Button – Turn power ON or OFF during idle time and maintenance.
3.	Clamshell – Holds upper section of Print Engine including Printhead and Service Station. Lifts up to clear media path.
4.	Control Panel Touchscreen – Displays Menu and information about Printer status. Controls Printer functions and setup.
5.	Ink Tank Door – Access to Ink Tanks. When open, a switch disconnects Printer communication to Ink Tanks and allows safe Ink Tank installation and replacement.
6.	Adjustable Media Guide – Adjusts to hold media against Stationary Media and Alignment Guides.
7.	Fixed Media Guide – Keeps media aligned as it enters the Printer.
8.	Top Forwarding Wheels Assembly and Forwarding Rollers – Move media smoothly into the Printer.
9.	Adjustable Media (Entry) Sensor Assembly – Aligns the Media Sensor to accurately read irregular-shaped media (<i>such as die-cut ovals or circles</i>).
10.	Network Port – Ethernet cable plugs in here.
11.	USB Port – USB cable attaches to Printer here.
12.	Interface Port – Connect an external device.
13.	Unwinder Interface Port – Unwinder Interface Cable plugs in here.
14.	Main Power Switch, Receptacle and Fuse – Plug in power cord here. Switch turns main power ON/OFF. (<i>Use Control Panel LED Power switch to turn off machine for cleaning and maintenance</i>). Fuse protects Printer's electronic circuits.

SECTION 1
GETTING ACQUAINTED

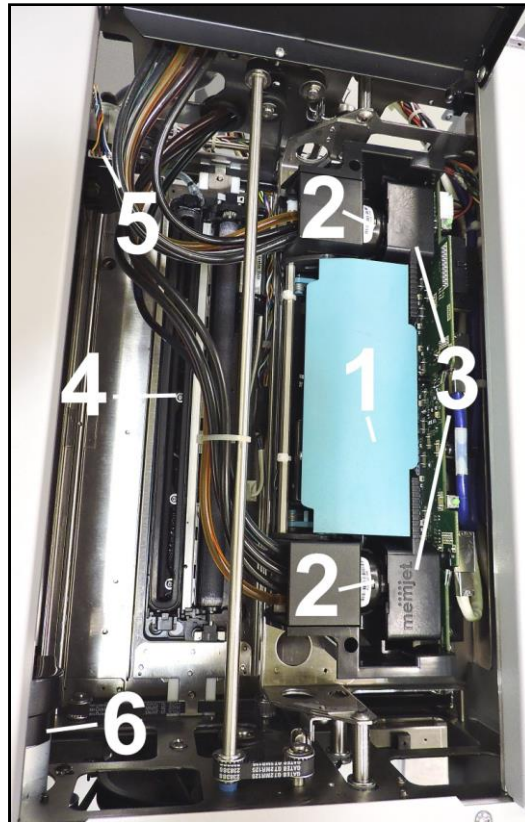

Print Engine View

1.	<p>Printhead Latch – When closed, connects Ink Revolver Couplings with Printhead Cartridge. When opened, retracts Ink Couplings from Printhead Cartridge and provides access to Printhead Cartridge for cleaning and replacement.</p> <p>WARNING! Never attempt to open Printhead Latch manually, severe damage will result. Use the Printhead Release in the Touchscreen "Service" drop-down menu when no ink is in system. Use System Deprime when ink is in system.</p>
2.	<p>Ink Revolver Couplings – Connect ink hoses to Printhead Cartridge. Printhead Latch extends and retracts couplings from Printhead.</p>
3.	<p>Printhead Cartridge – Memjet® Printhead produces an 8.5" wide full color print area.</p>
4.	<p>Service Station – Cleans Printhead Cartridge of excess ink and debris, keeps Printhead hydrated and protected when not in use, captures and removes ink used to keep nozzles clear, and moves out of the way of the Printhead during printing.</p>
5.	<p>Service Station Inspection Motor – Moves the Service Station in and out from under the Printhead Assembly for inspection, cleaning or service.</p>
6.	<p>Printhead Assembly Lifter Motor – Lifts and lowers the Printhead Assembly over the Service Station for Service Station access and Printing.</p>

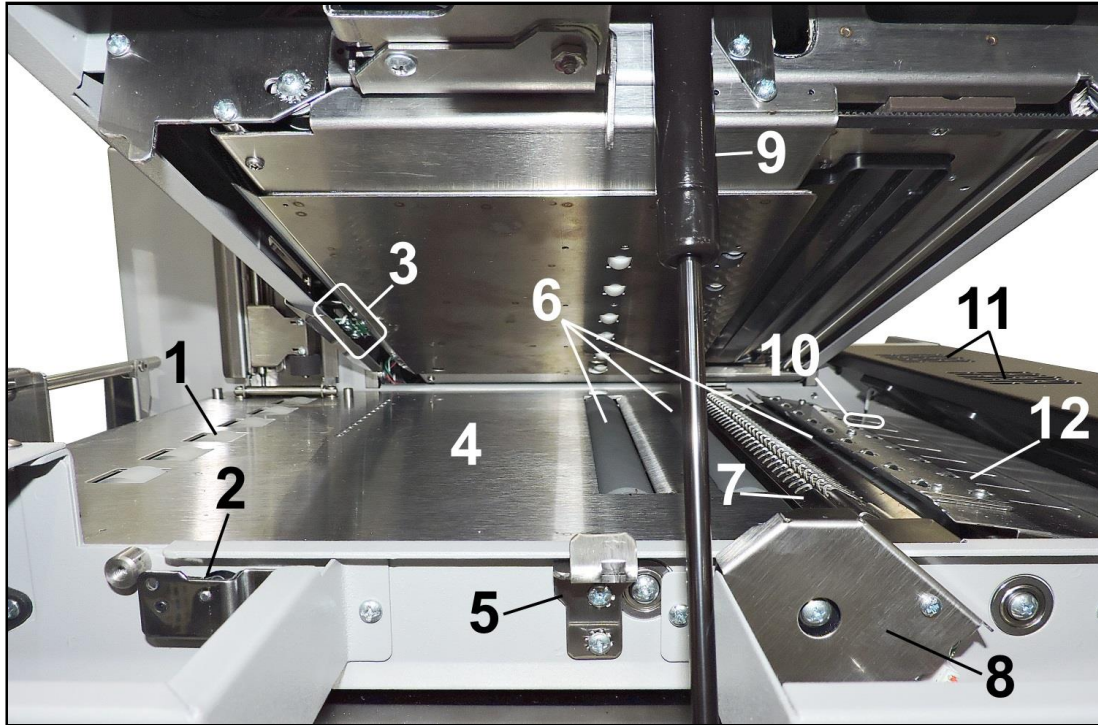

Print Area View (Under Clamshell)

1.	Forwarding Rollers – Move media into Printer.
2.	Clamshell "Open" Switch – Signals Printer when the Top Assembly Latch is released and Top Assembly is opened. Shows on Touchscreen display and in Toolbox System Status icon.
3.	Adjustable Media (Entry) Sensor – Aligns the Media Sensor to accurately read irregular-shaped media (<i>such as die cut ovals or circles</i>).
4.	Print Platen – Flat surface helps media transport smoothly through Print Area.
5.	Clamshell Latch – Release to raise Top Assembly to clear media jams or for cleaning and other maintenance.
6.	Transport Rollers – Keep media moving through Print Area.
7.	Ink Drip Cover and Tray – Located under Printhead. Catches any excess ink coming from Service Station and Printhead.
8.	Encoder Assembly and Guard.
9.	Support Strut – Supports Top Assembly when raised.
10.	Media (Exit) Sensor – Signals Printer that media has exited the Printer.

SECTION 1
GETTING ACQUAINTED

11.	Ink Vapor Exhaust Fans – Draw ink vapor out of the Print Area and away from the Exit Sensor.
12.	Exit Starwheel Assembly – Helps media exit smoothly from Printer.

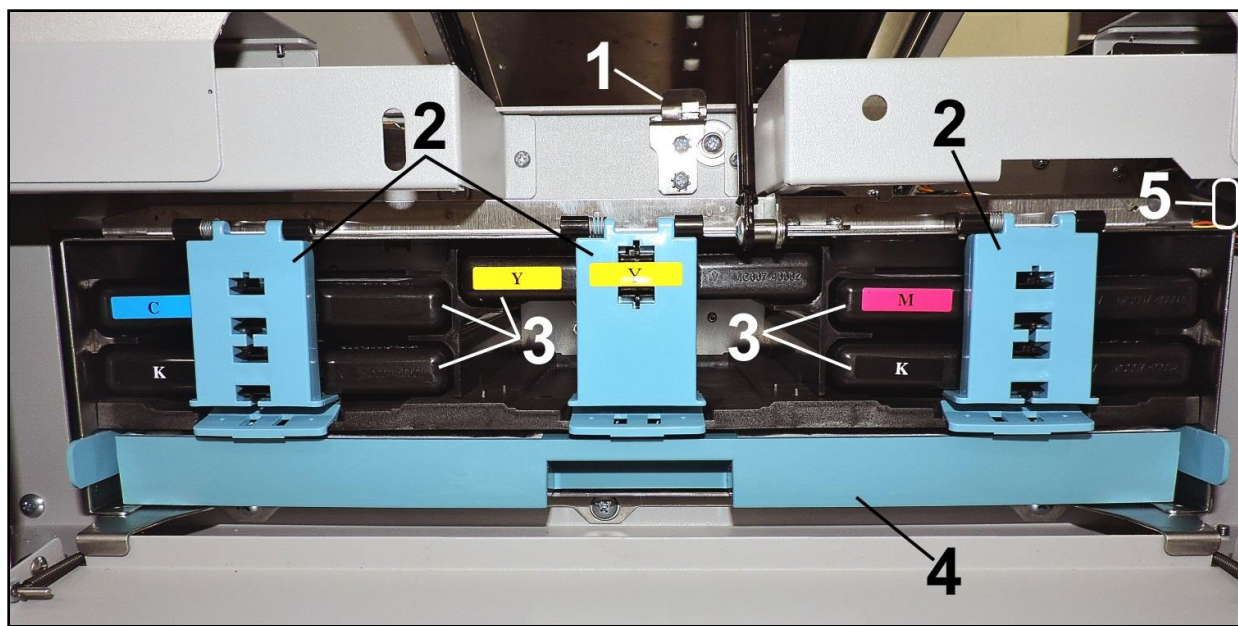

Ink Tank Door View

1.	Print Engine Assembly Latch – Release to raise Printhead Assembly to clear media jams or for other maintenance.
2.	Ink Tank Latches – Used to hold Ink Tanks in slots. NOTE: Make sure both sides at bottom part of latch are engaged.
3.	Ink Tanks – Printer has five Ink Tanks: Cyan, Yellow, Magenta, and two Black. LP2-21 Cyan, LP2-22 Yellow, LP2-23 Magenta, LP2-24 Black
4.	Ink Waste Tray – Catches any waste ink produced by system. Tray is filled with absorbent material. Pull on tab to remove Tray.
5.	Ink Tank Disconnect Switch – When Ink Door is opened, Switch shuts down communication between Printer and Ink Tanks for safe removal and replacement.

**SECTION 1
GETTING ACQUAINTED**

Unwinder / Rewinder

The ColorMaxLP2 comes standard with two universal winding units. The units become an Unwinder or Rewinder based on their configuration and position in relation to the ColorMaxLP2.

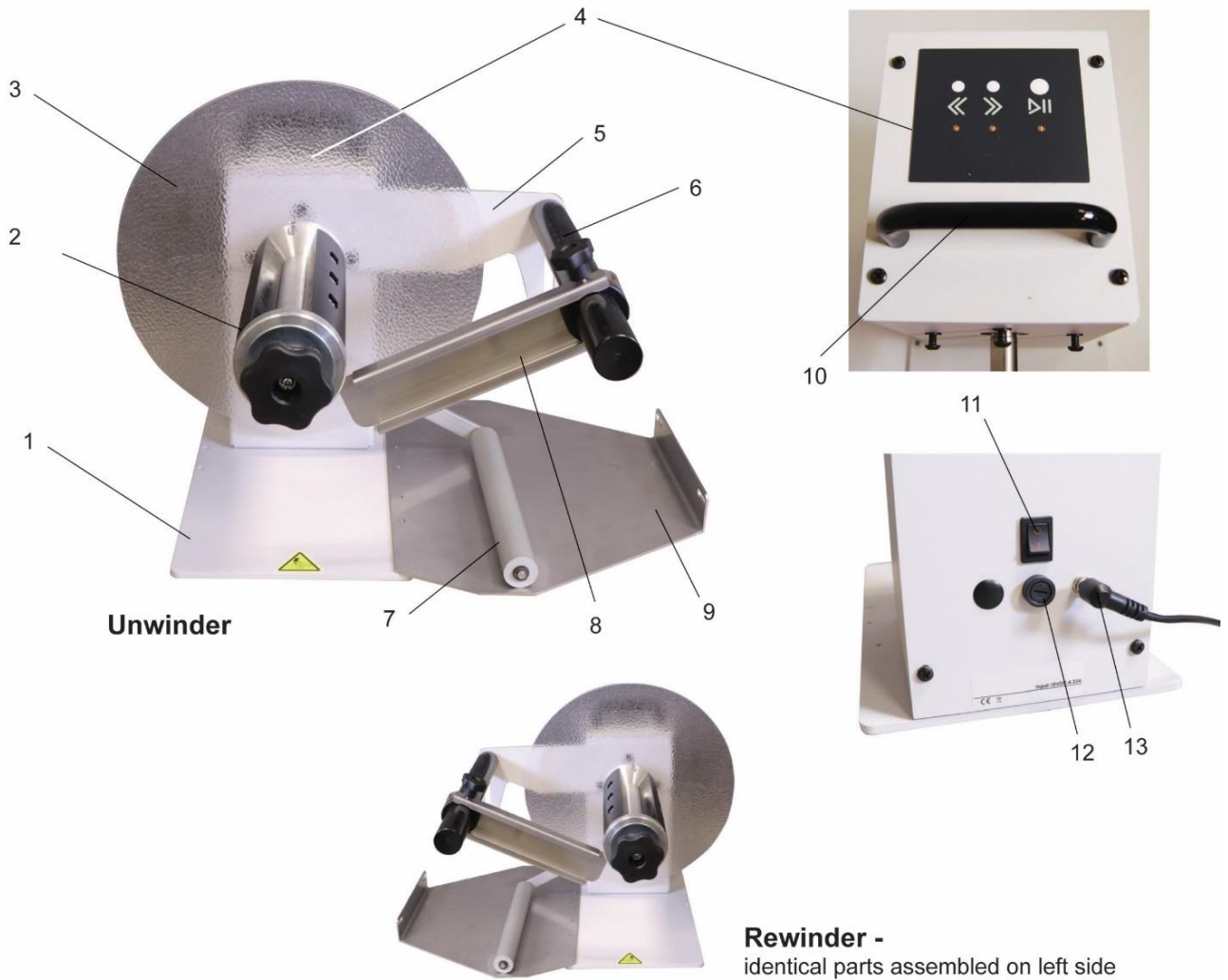

1.	Unwinder/Rewinder base and power unit
2.	Quick-locking core chuck - Makes loading and unloading label rolls easy with just a twist
3.	Inner flange - Disc helps to align label roll
4.	Control panel - controls direction and starting/stopping of unwinding/rewinding
5.	Bracket guide - holds guide shaft and media guide in place
6.	Guide shaft - assists with feeding label web off and onto the roll
7.	Tension arm - automatically adjusts to provide correct tension for feeding label web
8.	Media guide - assists with aligning labels while feeding
9.	Alignment plate - attaches to winder/unwinder and the printer to keep each aligned properly
10.	Lifting handle
11.	Power switch
12.	Fuse access
13.	Power cord input

SECTION 2 – *Installing Printer*

Contents of Packaging

1.	ColorMaxLP2 Label Printer
2.	Ink Drip Tray Assembly
3.	Ink Tanks – Printer has five Ink Tanks: Cyan, Yellow, Magenta, and two Black. LP2-21 Cyan, LP2-22 Yellow, LP2-23 Magenta, LP2-24 Black
4.	Printhead Cartridge
5.	AC Power Cord
6.	USB Cable (10-Ft.)
7.	Ethernet Cable (10-Ft.)
8.	Quick Start Guide
9.	Driver Software: USB Flash Drive (<i>Includes Printer Driver and Operator Manual</i>)
10.	Unwinder/Rewinder (2 universal units)

Before using the ColorMaxLP2 Label Printer:

- Choose a location for the Printer, Unwinder & Rewinder
- Unpack the Printer, Unwinder & Rewinder
- Remove shipping materials from the Printer
- Install the Ink Drip Tray
- Plug in the Printer and connect it to a computer or network
- Install the Printer Driver
- Install the Ink Tanks and Printhead
- Assemble and connect and align the Unwinder and Rewinder to the Printer
- Set up the feed on the Printer

Choose a Suitable Location

Place the Printer on a sturdy level worktable or cabinet at least 9" from any walls. Open the Ink Tank Door and raise the Clamshell Assembly. Use the Bubble Gauge mounted on the Ink Station Frame (*or a small level*) placed on the Ink Station Frame to make sure the Printer is level. Protect the Printer from excessive heat, dust, and moisture. Avoid placing it in direct sunlight.

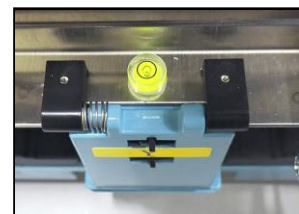

SECTION 2 INSTALLING PRINTER

Unpack and Set-up

Remove the Printer and its parts from the carton. Remove all packing materials and tape. Install the Ink Drip Tray Assembly before operating the Printer.

WARNING

TO AVOID POSSIBLE DAMAGE TO THE PRINTER; DO NOT PLUG-IN OR POWER-UP THE PRINTER UNTIL ALL SHIPPING MATERIALS ARE REMOVED.

1. Open the **Top Cover**.
2. Remove the Foam Shipping Block [A]. (*Color of foam block may vary.*)
NOTE: Foam Shipping Block is used to secure the Service Station Sled during transport.
3. Cut and remove the two yellow zip-ties [B].
NOTE: These zip-ties are used to secure the Wiper Motor Assembly during transport. DO NOT cut the white or black zip-ties used to restrain the Ink Hoses. **IMPORTANT: Remove all cut pieces of the yellow zip-ties from the Printer.**
4. Gently close the **Top Cover**.
5. Remove the protective film from the **Touchscreen**.

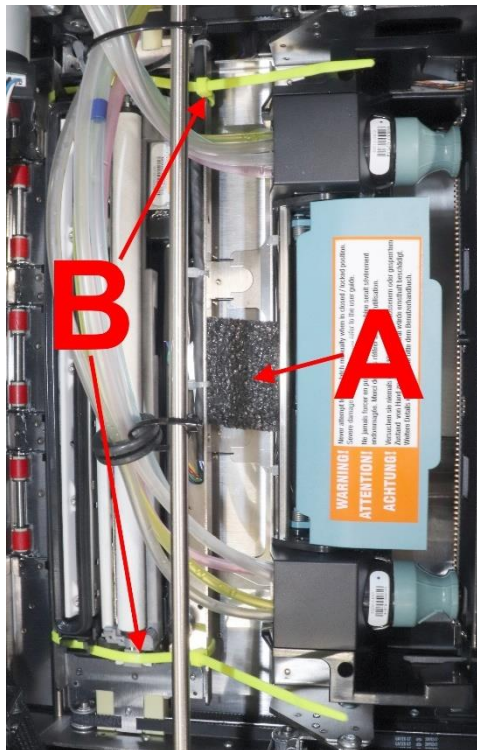

Install Ink Drip Tray Assembly



1. Open the Ink Tank Door [A].
2. Release Latch [B] to raise the Clamshell.
3. Insert tabs on the Ink Drip Tray into the frame slots [C] as shown.
NOTE: If necessary, bend the tab on the Grounding Spring [D], so it touches the bottom of the Ink Drip Tray tab.
4. Close the Clamshell.

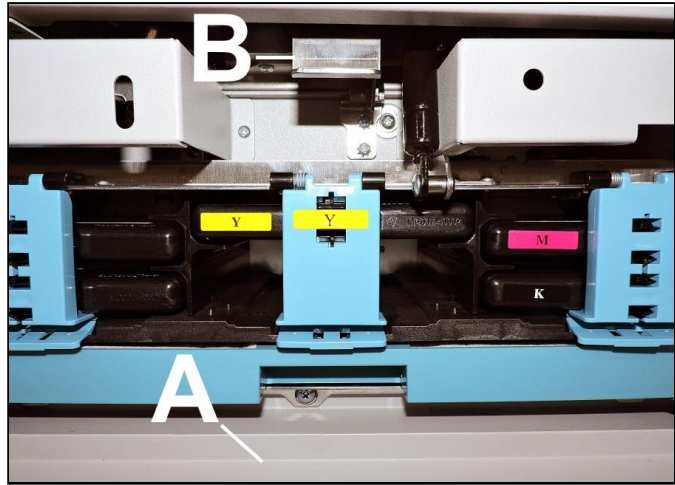

SECTION 2 INSTALLING PRINTER

The ColorMaxLP2 comes standard with two universal winding units. The units become an Unwinder or Rewinder based on their configuration and position in relation to the ColorMaxLP2.

The Alignment Plates allow proper spacing and alignment between the winding units and the Printer.

CONTENTS:

Item	Description	Qty
1.	Unwinder/Rewinder unit	2
2.	Media guide	2
3.	Tension arm with setscrew and shaft screw	2
4.	Bracket guide	2
5.	Black shaft with bolt and washer	2
6.	Quick locking core chuck	2
7.	Inner flange	1
8.	Alignment plate to provide proper spacing between Unwinder/Rewinder and ColorMaxLP2	2
9.	Thumbscrews to attach alignment plate to ColorMaxLP2	4
10.	Set screws to attach alignment plate to Unwinder/Rewinder	4
	Allen wrench for attaching quick locking core chuck to drive shaft (not shown)	1
	Power supply (not shown)	2

NOTE: The unwinder/rewinder is only to be used with roll labels/paper, of the recommended dimensions and weight, in an indoor environment. Unplug the device before changing configuration.

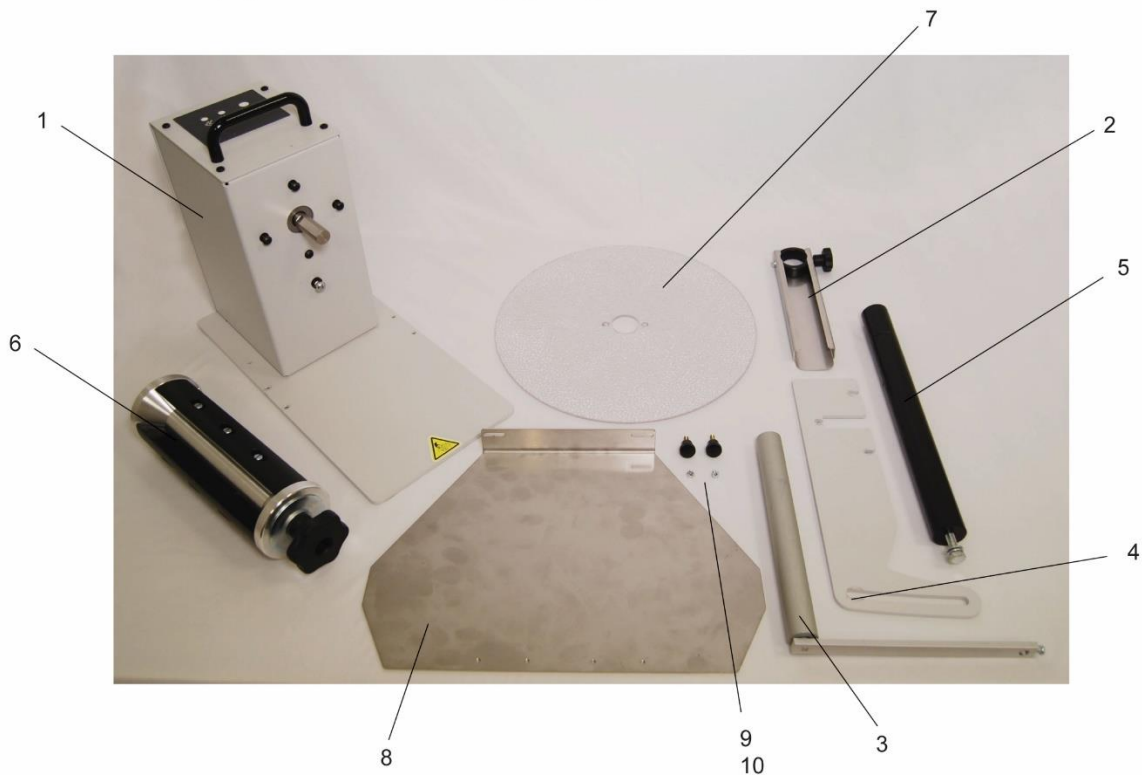

UNWINDER ASSEMBLY

1. Attach the Alignment Plate to the base of the Unwinder using the two countersunk screws provided.

The Unwinder will be positioned on the left side of the printer; attach the alignment plate to the right side of the Unwinder base.

TIP: To make the Alignment Plate attachment process easier, carefully lay the Unwinder onto its back (power switch side). Be careful not to damage the power switch.

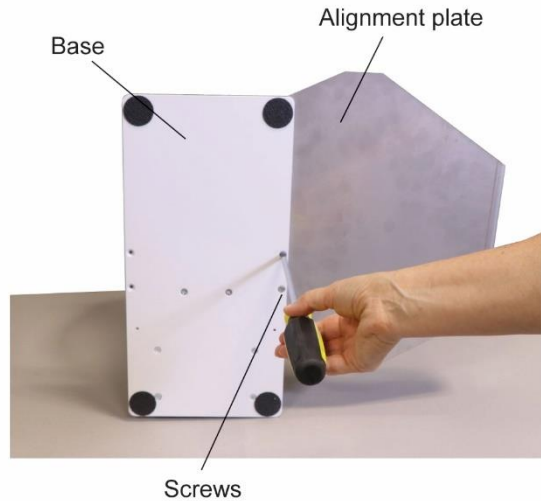

Installing the Tension Arm

For the Unwinder the Tension Arm is mounted on the RIGHT side of the unit

1. Using an Allen wrench, remove and set aside the large screw from the end of the Tension Arm Shaft (shaft below the Main Motor Shaft). (Fig. 1)

Tension Arm Shaft

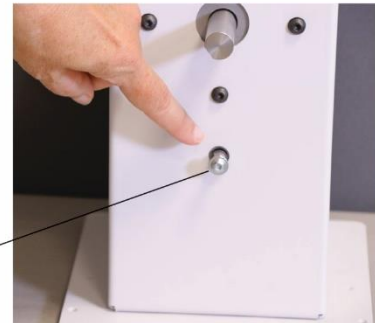

Fig. 1

3. With a Phillips screwdriver, loosen the set screw at the end of the Tension Arm. Position the Arm with the set screw facing the flat side on the Tension Arm Shaft. (Fig. 2)

Set screw



Fig. 2

4. Tighten the set screw facing the flat on the tension arm shaft. (Fig. 3)

5. Re-insert and tighten the Tension Arm Shaft Screw into the Tension Arm Shaft and tighten with an Allen wrench. (Fig. 3)

Tension Arm Shaft Screw



Fig. 3

SECTION 2 INSTALLING PRINTER

Installing the Bracket Guide Kit

For the Unwinder the Bracket Guide is mounted on the Right side of the unit

1. Using an Allen wrench, loosen the 3 upper screws on the front of the unwinder/rewinder chassis (Fig. 4: A, B, C).

CAUTION: Do NOT remove screws as these screws also secure the motor to the inside of the chassis.

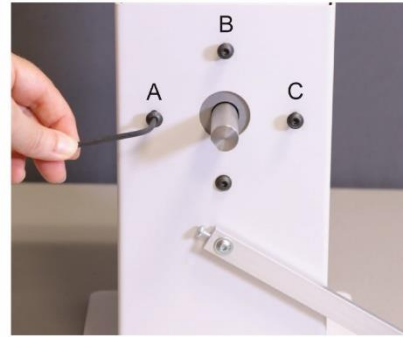

Fig. 4

2. Slide the Bracket Guide in between the screws and chassis as shown. Retighten screws to secure the Bracket Guide.

Bracket Guide

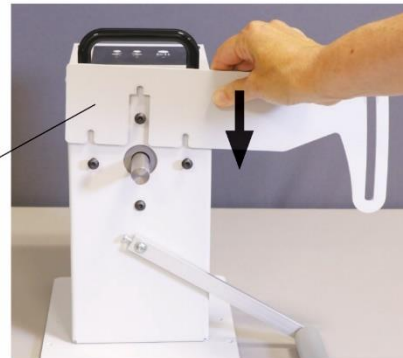

Fig. 5

3. Attach the Black Shaft to the slotted hole in the Bracket Guide, with one washer on each side of the guide. (Fig. 6)

Position Black Shaft as low as possible, within slotted hole, before securing.

Black Shaft



Fig. 6

4. Attach the Media Guide to the Black Shaft. Loosen the thumb wheel, slide the guide onto the shaft and finger tighten the knob. (Fig. 7)

Once the label roll is loaded, the guide will be moved into place to help labels unwind smoothly.

Thumb wheel



Fig. 7

Media Guide

Installing the Inner Flange and Quick Locking Core Chuck

1. Remove the two screws on the end of the Quick Locking Core Chuck.(Fig. 8)

Align the two holes on the Inner Flange and attach to the Chuck using the two screws.

Core Chuck

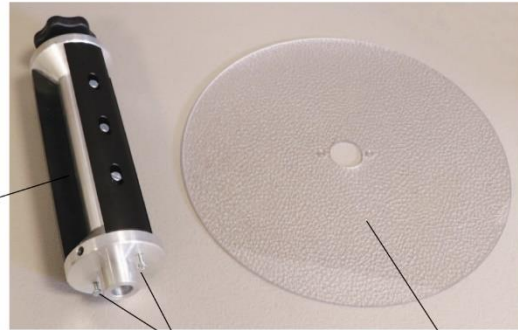

Fig. 8 Mounting Screws Inner Flange

2. Slide the Quick Chuck and Flange Assembly onto the unwinder/rewinder Motor Shaft allowing for clearance to the Chassis and Motor Screws. (Fig. 9)



Fig. 9 Motor Shaft

Tighten the Allen Screw onto the flat part of the Motor Shaft until it is tight. (Fig. 10)



Fig. 10

3. When fully assembled, the Unwinder should look like Fig. 11.

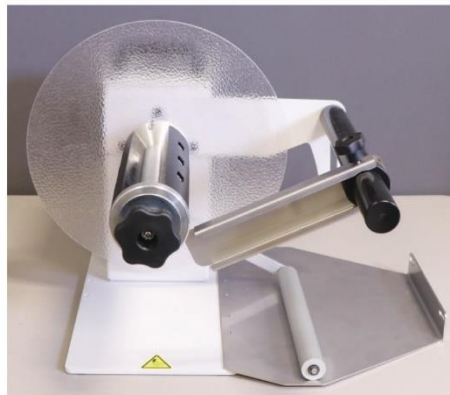

Fig. 11

SECTION 2 INSTALLING PRINTER

Attaching the Unwinder and Alignment Plate to the Printer

1. Position the Unwinder, with Alignment Plate attached, at the Left side of the printer. (Fig. 12)



Fig. 12

2. Attach the Alignment Plate to the printer using two thumb screws and washers, provided with printer. (Fig. 13)



Fig. 13

Thumb screws

Connecting the Power Supply

1. Set the Power Switch, located on the back of the unwinder/rewinder, to the OFF (0) position.
2. Connect the 15V Power Supply to the power plug inlet, then connect to an AC Outlet. (Fig. 14)



Fig. 14

REWINDER ASSEMBLY

The Rewinder assembly sequence is identical to the Unwinder, EXCEPT the Alignment Plate, Tension Arm, and Bracket Guide Kit are mounted on the LEFT side of the unit.

1. The fully assembled Rewinder Unit should look like Fig. 15.
2. Position the Rewinder, with Alignment Plate attached, at the Right side of the printer.
3. Attach the Alignment Plate to the printer using two thumb screws and washers, provided with printer.

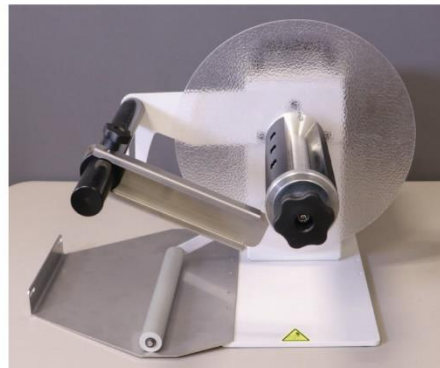

Fig. 15

Connect Printer

Plugging in Printer

Plug the power cord into the receptacle [1] located on the rear panel of the Printer. Internal power supply in the Printer is rated 100 to 240VAC, 50/60 Hz.

CAUTION

DO NOT USE ADAPTER PLUGS OR EXTENSION CORDS TO CONNECT THE PRINTER TO WALL A RECEPTACLE.
DO NOT USE OUTLETS CONTROLLED BY WALL SWITCHES.
DO NOT USE OUTLETS THAT SHARE THE SAME CIRCUIT WITH LARGE ELECTRICAL MACHINES OR APPLIANCES.



Connect to Computer

Printer connects to the computer through the **USB Port** [2].

Network Port [3] for connecting to a network.

See “**Network Connection Setup**” in “**Using Control Panel Touchscreen**”.

Once the Printer is connected and set up, opening the Printer Toolbox displays the Printer(s) available and whether they are connected to the network or by USB cable. You can then select the desired Printer to open its Toolbox screens. **NOTE:** If the symbol is grayed out or blank, that Printer is not currently connected.

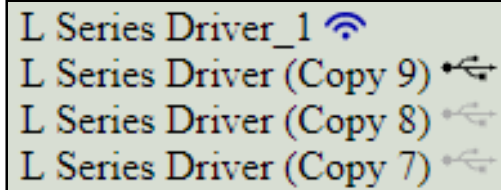

Turning Power ON and OFF

IMPORTANT!

CLOSE ALL COVERS AND DOORS BEFORE STARTING OR POWERING DOWN THE PRINTER.

IMPORTANT! START ONE PRINTER AT A TIME WHEN SIMILAR PRINTERS ARE ON THE SAME NETWORK.

Powering Up Printer:

1. Press Main Power Switch on Rear Panel.
2. Press Power Button on Control Panel.

Powering Down Printer:

CAUTION

WHENEVER POWERING DOWN THE UNIT, ALWAYS:

1. CLOSE ALL COVERS.
2. PRESS THE POWER BUTTON ON THE CONTROL PANEL.
3. WAIT FOR THE PRINTER TO STOP PROCESSING.
4. THEN PRESS THE MAIN POWER SWITCH ON THE REAR PANEL.

SECTION 2 INSTALLING PRINTER

Install Printer Driver

For the Printer software to operate properly, check that the hardware meets **minimum requirements**:

- **Operating System:** Windows 8/8.1, Windows 10 (*Desktop Mode only*). Windows XP, Windows Vista, Windows 7. Supports 32 and 64 bit systems. (*You must have administrative privileges on system.*)
NOTE: Windows 8, 8.1 and Windows 10 will only work in desktop mode. No Windows 8 or 10 metro apps will be supported (*applications that work ONLY in Windows 8 or 10 environments*).
- **Microprocessor:** Pentium II, 2 GHz minimum (*Pentium Dual Core, 2.5 GHz or better, is optimal*)
- **System memory:** 2 GB minimum; or as recommended for your operating system.
- **Free hard-disk space:** At least 10 GB.
- **Web Browser:** Firefox recommended; Chrome, Safari, and Opera also supported.
- **Ethernet Speed:** 1,000 Mbps.
- **USB port (2.0/3.0):** (*Ports will be identified as "USB" or "Enhanced" in Device Manager*)
- Microsoft .Net Framework version 3.5 (*for 32 bit systems*) or Microsoft .Net Framework version 4 (*for 64 bit systems*) must be installed. **NOTE:** Even if a newer .NET Framework version is installed; version 3.5 or 4 must also be installed, or Toolbox will not open.

IMPORTANT: Before installing the Printer software (*Toolbox and Driver*), **temporarily disable all antivirus programs and firewalls**. In addition, you must be logged onto the system with full administrative privileges (*admin rights*). **NOTE:** If installing over USB, **do not plug in the USB cable until prompted**.

Install Over USB Connection

This is the procedure for installing the Print Driver over the USB connection. The procedures for installing the Print Driver over a network connection follow.

1. Check that Printer is plugged in and turned OFF. **Disconnect the USB connection if it is already plugged in.** Insert the Printer Driver USB Flash Drive supplied with the Printer into your computer's USB port. **Open the USB Flash Drive Directory:** Open the "**L-Series**" folder. Open the "**Driver**" folder. Open the "**Driver Version**" folder. Select and click "**Setup.exe**" to start.
2. **Install Printer Software.** Make sure the system meets **minimum requirements** and you followed the other instructions listed on the screen. Click "**Install Printer Software**".

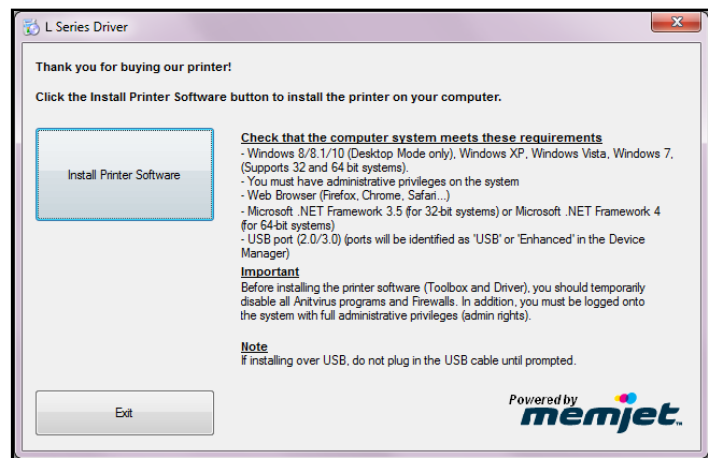

3. **License Agreement.**

Check “I accept...” then click “Next>”.

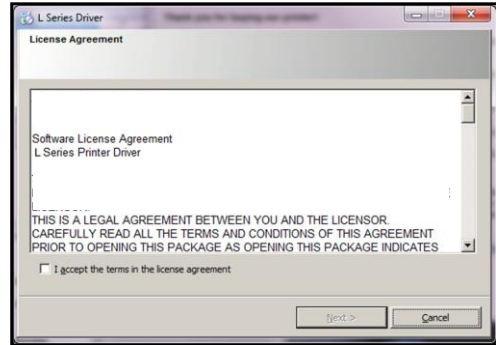

4. **Printer Connections.** Click “Configure to print using USB”. Then click “Next>”.

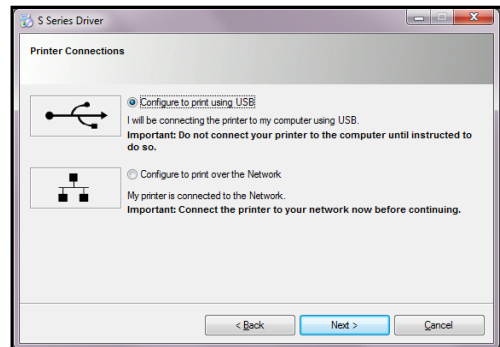

5. **Installing Printer Software.**

Software download begins.

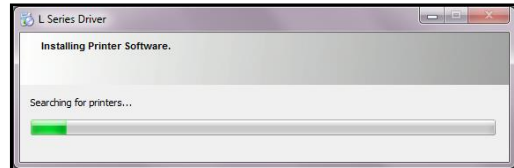

6. **Would You Like to Install This Device Software?**

Click “Install”.

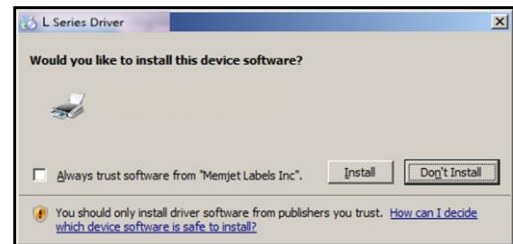

7. **Connect Device Now.** Turn the Printer ON and connect the USB cable. **Don't click on either button.** Software will finish installing.

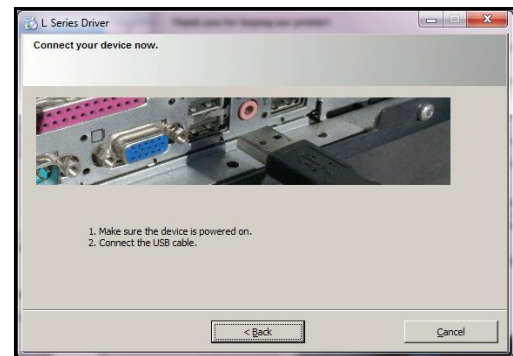

SECTION 2 INSTALLING PRINTER

- Finished software installation.** Do not check the **Print Test Page** as the Printer is not set up yet. You can check “Set this printer as the default printer” at this time. Click “**Finish**”.

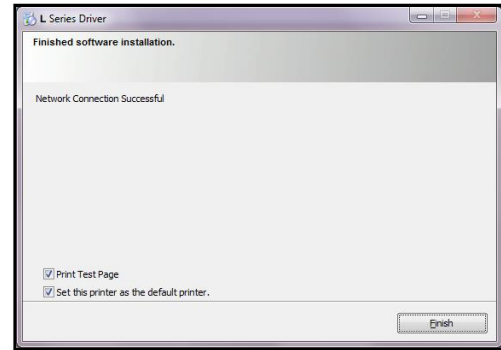

- Install Printer Software.**
Click “**Exit**” to close the program.
- Restart computer to complete the installation.

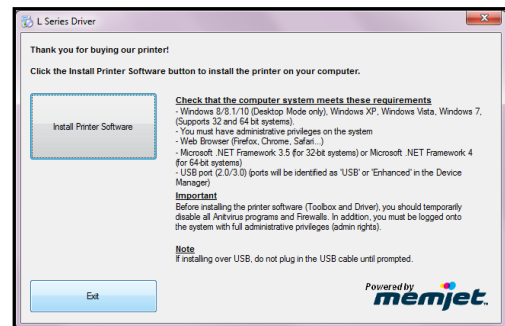

Install Over Network Connection, Version A

Use this procedure to install the Print Driver over the Network connection. This procedure works for almost all networks that allow automatic assignment of the IP address (*factory default*).

NOTE: Copy the 12-digit Hardware ID number listed on the Printer(s) on the label located below the Ethernet port so you can identify the Printer(s) in a later step.

- Check that Printer is plugged in and turned OFF. **Disconnect the USB connection if it is already plugged in.** Insert the Printer Driver USB Flash Drive supplied with the Printer into your computer's USB port. **Open the USB Flash Drive Directory:**
Open the “**L-Series**” folder.
Open the “**Driver**” folder.
Open the “**Driver Version**” folder.
Select and click “**Setup.exe**” to start.
- Install Printer Software.** Make sure the system meets **minimum requirements** and that you followed the other instructions listed on the screen. Click “**Install Printer Software**”.

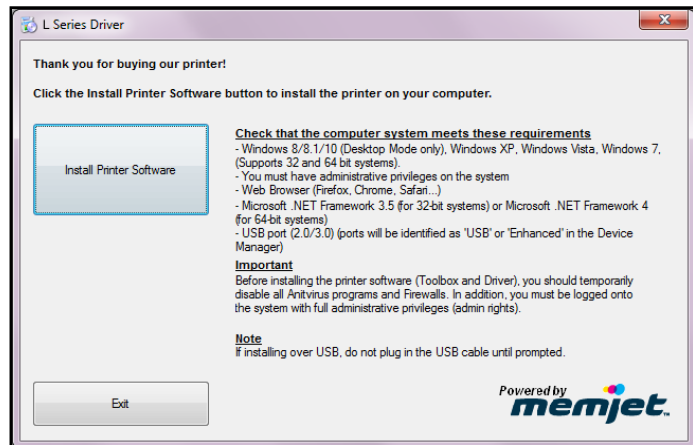

3. License Agreement.

Check “I accept...” then click “Next>”.

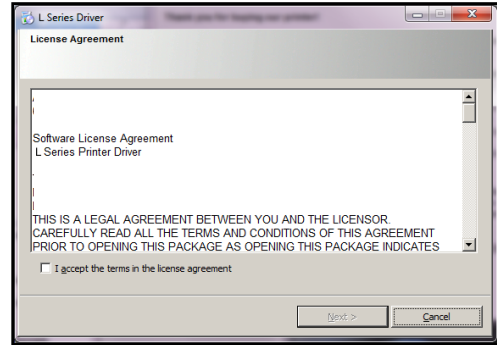

4. Printer Connections. Click “Configure to print using the Network”. Make sure the Printer is connected to the Network. Then click “Next>”.

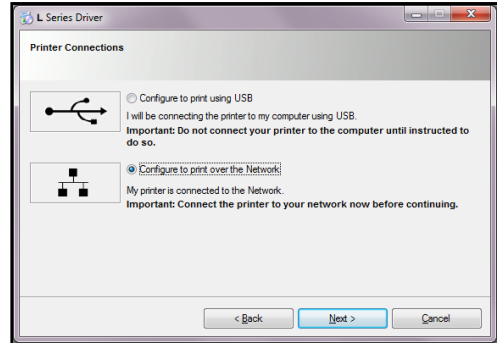

5. Printers Discovered. A list of available Printers opens. Check the **Printer** column to verify you have an **L-Series** printer. Check the **Hardware ID** column and match the number listed to the number you copied previously from the Printer label. Select that Printer. Click “Next>”.

NOTE: If the Printer does not appear on the list, the IP address may have to be assigned manually. See “Install Over Network Connection, Version B”.

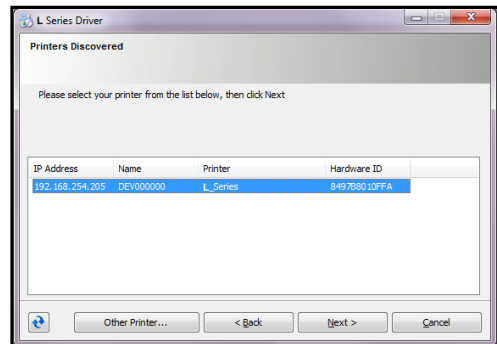

6. Installing Printer Software.

Software download begins.

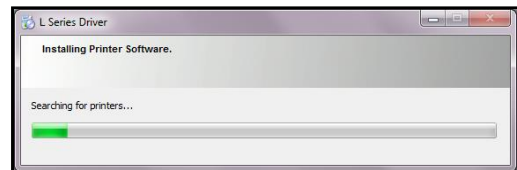

7. Would You Like to Install This Device Software?

Click “Install”.

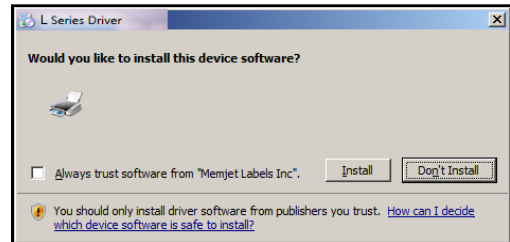

SECTION 2 INSTALLING PRINTER

8. **Finished software installation.** Do not check the **Print Test Page** as the Printer is not set up yet. You can check “Set this printer as the default printer” at this time. Click “**Finish**”.

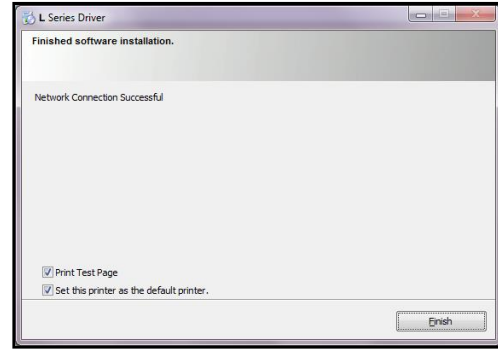

9. **Install Printer Software window.** Click “**Install Print Software**” again to install software on another Printer, or click “**Exit**” to close the program.

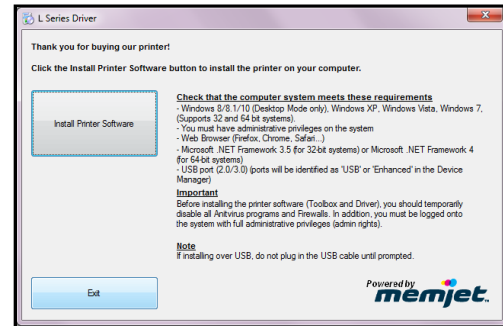

Tip: To help distinguish between multiple L-Series Drivers on your system; open the “**Printers and Faxes**” (*Devices and Printers*) folder and rename the Printers. **For example**, rename a network-configured printer “**L Series (Network-1)**” and a USB-configured printer “**L Series (USB)**”.

To open the “Toolbox” utility over an Ethernet (network) connection:
Click **Start, All Programs, Memjet, L-Series Driver, Toolbox**.

If more than one copy of the L-Series Driver is installed, you will have to choose which device you want the **Toolbox** to connect to. To help choose the proper device, you can identify the Printer(s) using the **Hardware ID** you copied earlier or you can rename the Printer(s) as outlined in the **Tip** above.

Example:

L-Series Driver configured for USB: suggested name “**L Series (USB)**”

L-Series Driver (Copy 1) configured for Network: suggested name “**L Series (Network-1)**”.

L-Series Driver (Copy 2) configured for Network: suggested name “**L Series (Network-2)**”.

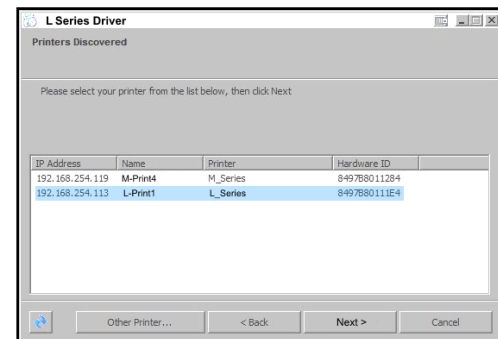

Install Over Network Connection, Version B

Use this procedure to install the Print Driver over the Network connection on **Static IP** systems requiring that an IP address is assigned manually. **NOTE: Copy the 12-digit Hardware ID number listed on the Printer(s) on the label just below Ethernet port so you can identify the Printer(s) in a later step. NOTE: This procedure can also be performed from the Touchscreen or Toolbox.**

1. **Touchscreen:** In “Menu”, tap “Setup”. On the **Service** screen, tap “**Network Config**”. The “**Network Configuration**” screen opens. Uncheck the DHCP button. You or your IT person can enter the necessary information under “**Network Configuration**”. Tap “**Submit**”.

Toolbox: Install the Printer Software over a USB connection using a nearby computer or laptop. Once the Driver and Firmware are installed on the Printer, use that same computer to open the **Printer Toolbox**.

In the “**View**” drop-down menu, click “**Service Menus**”. When the **Diagnostic** screen opens, click the “**System Settings**” button.

The “**System Settings**” screen opens.

Uncheck the DHCP button. Your IT support person can fill in the necessary information under “**Network Settings**” (or you can get it from them.) Click “**Submit**”.

NOTE: Disconnect the USB from the local computer or laptop. If not using that computer for printing, the S-Series Software can be uninstalled.

2. Connect the Ethernet cable to the Ethernet port and rerun the “**Install Over Network Connection, Version A**” procedure. The Printer should now appear on the “**Printers Discovered**” window. The Printer can still be identified by its “**Hardware ID**”, but the new IP address entered by your IT support person (or operator) is shown. Select the desired Printer and click “**Next>**”. Follow the remaining steps.

SECTION 2 INSTALLING PRINTER

3. **Installing Printer Software.** Software download begins.

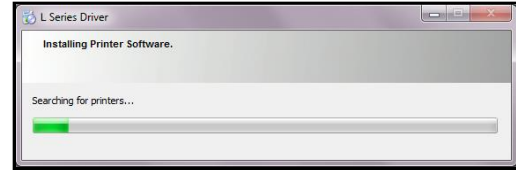

4. **Would You Like to Install This Device Software?**
Click “Install”.

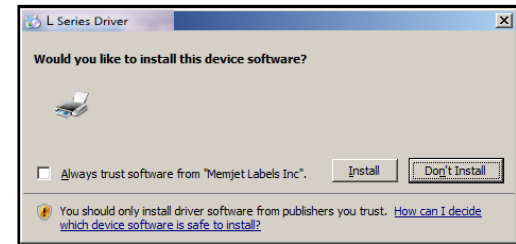

5. **Finished software installation.** Do not check the **Print Test Page** as the Printer is not set up yet. You can check “Set this printer as the default printer” at this time. Click “Finish”.

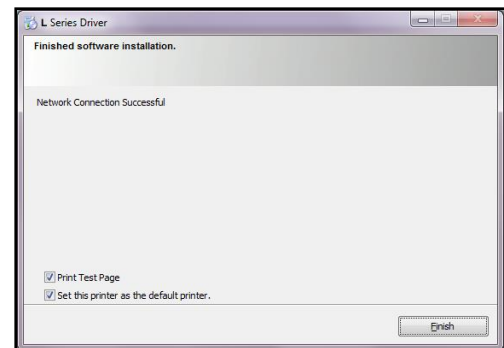

6. **Install Printer Software window.**
Click “Exit” to close the program.

Tip: To help distinguish between multiple L-Series Drivers on your system; open the “**Printers and Faxes**” (*Devices and Printers*) folder and rename the Printers. **For example**, rename a network-configured printer “**L Series (Network-1)**” and a USB-configured printer “**L Series (USB)**”.

To open the “Toolbox” utility over an Ethernet (network) connection:

Click **Start, All Programs, Memjet, L-Series Driver, Toolbox.**

If more than one copy of the L-Series Driver is installed, you will have to choose which device you want the **Toolbox** to connect to. To help choose the proper device, you can identify the Printer(s) using the **Hardware ID** you copied earlier or you can rename the Printer(s) as outlined in the **Tip** above.

Example:

L-Series Driver configured for USB: suggested name “**L Series (USB)**”

L-Series Driver (Copy 1) configured for Network: suggested name “**L Series (Network-1)**”

L-Series Driver (Copy 2) configured for Network: suggested name “**L Series (Network-2)**”

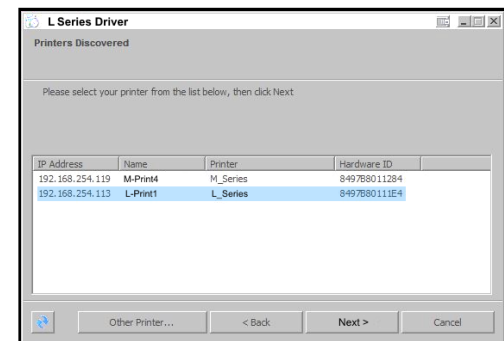
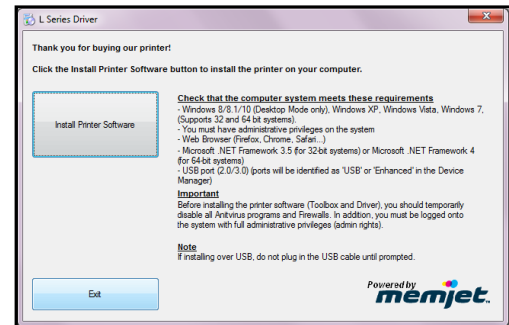

Install Ink Tanks

The Printer uses one Printhead Cartridge and five Ink Tanks (two Black, one Cyan, one Magenta, and one Yellow).

1. Look at the Control Panel Touchscreen.

Ink Tank status information appears on the right side of the Touchscreen. Note that the **Ink Tank** indicator boxes are empty. **NOTE:** The question marks indicate that no Ink Tanks are detected by the Printer.

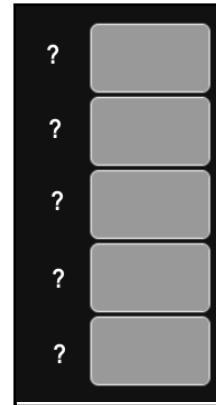

CAUTION

VERIFY THAT THE LABELS ON THE INK CARTRIDGE AND THE PRINTER'S INK STATION MATCH. BOTH SHOULD BE "DN" OR BOTH SHOULD BE "DG".

- 2. Open the Ink Tank Door** (hinged at bottom). (Disconnects Printer communication with Ink Tanks and allows safe installation and replacement.)
Open Ink Tank Latches [A].

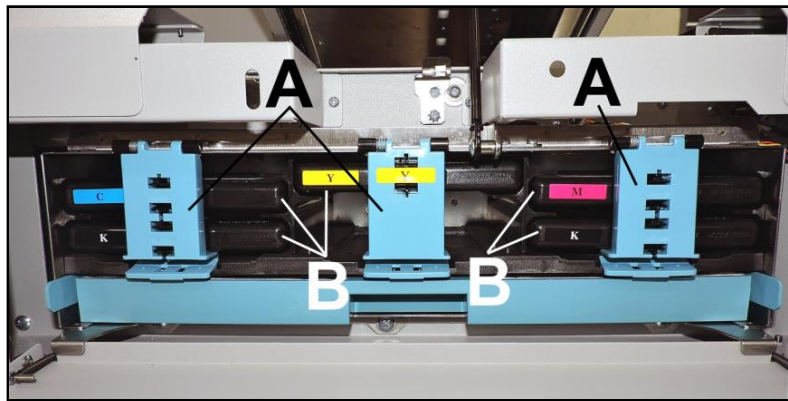

- 3. Remove the new Ink Tanks** from packaging.
- 4. Insert the Ink Tanks** (labels up) into the appropriate color slots [B]. Close the Ink Tank Latches.

INSTALLATION TIP: Make sure the Ink Tanks seat properly. Insert the Ink Tank into the appropriate Ink Station, then pull the Ink Tank back about an inch and push forward firmly to insure that the Ink Nozzles penetrate the seals on the Ink Tanks.

- 5. Close the Ink Tank Door.** Ink colors fill in as the Ink Tanks are installed. If the ink colors do not fill in after a few seconds, open the Ink Tank Door again and reinstall the Ink Tanks.

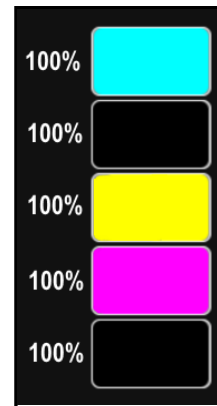

WARNING!

Ink in Ink Tanks may be harmful if swallowed. Keep new and used Ink Tanks out of the reach of children. Discard empty tanks immediately.

SECTION 2 INSTALLING PRINTER

First Time Install Printhead Cartridge

The Printhead Cartridge is a delicate precision device. Handle with extreme care to avoid damage and issues that could degrade print quality.

CAUTION

- Use electrostatic discharge (ESD) protection when handling.
- Hold the Printhead Cartridge by the handles **ONLY**.
- **DO NOT** touch the ink couplings, nozzle surface or electrical contacts.
- **DO NOT** unpack the Printhead Cartridge until the Printer is ready for installation. Once unwrapped, delay in installing the Printhead can compromise print quality due to dehydration.
- **DO NOT** place an unwrapped Printhead on any surface before installing. Protect the Printhead from scratches, dust, fibers, dirt and other contaminants at all times.

1. **Open the Top Cover.** The Printhead Latch [1] is shipped in the open position, if it is not: Close the Top Cover. Use the Touchscreen to tap **Menu**; then **Setup**. Press **Release Printhead**. The Printer runs, then the Latch [1] pops open. Open the Top Cover. **NOTE: Remove the Cap Protectors [2] on the Ink Nozzles.** Be sure to open the Latch fully to retract the Ink Nozzles.

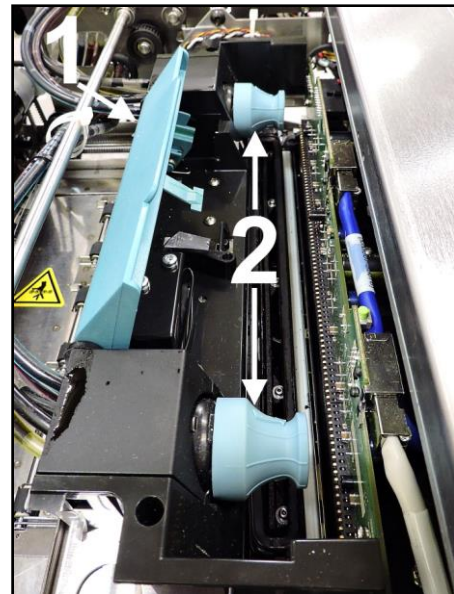
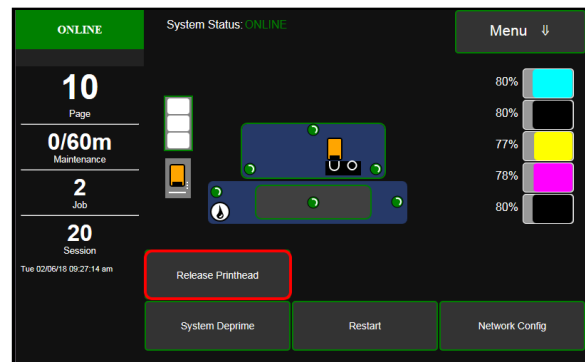
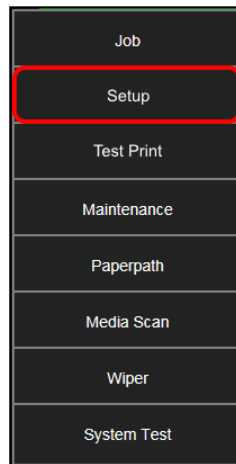

CAUTION

DO NOT PRY OR MANUALLY LIFT THE PRINTHEAD LATCH OR THE LATCH MAY BREAK. ONLY OPEN THE LATCH USING THE RELEASE PRINTHEAD BUTTON ON THE TOUCHSCREEN OR IN THE PRINTER TOOLBOX.

2. [A] Carefully remove Printhead Cartridge from foil packaging. Tear foil at notch or cut the end with scissors.



[B] Remove protective plastic cover. Hold Printhead by handle and unclip cover from Printhead.

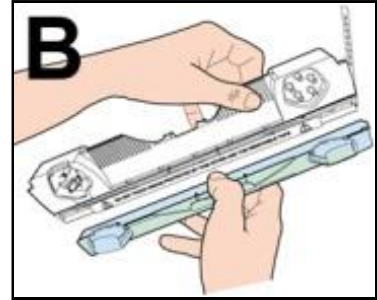

[C] Remove protective strip from Printhead Electrical Contacts. Once removed, DO NOT allow strip to touch electrical contacts.

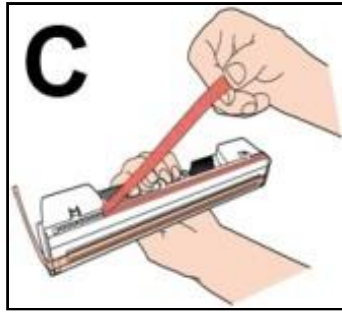

[D] Remove protective strip from Printhead Nozzles. Hold Printhead by the handle. Pull strip tab and slowly peel strip from Printhead. DO NOT pull strip at less than a 45° angle from Printhead surface. DO NOT allow removed strip to touch Printhead Nozzles.

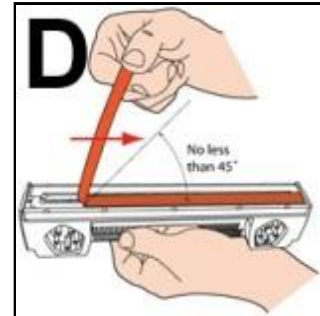

3. Wet Printhead Surface. (Ensures that Printhead will prime correctly.) Moisten Printhead nozzles using distilled water and a damp, lint-free cloth, wiping end to end. (Gray strip located below orange strip.) Take care not to damage copper contacts, metal plate, or gold Printhead surface.

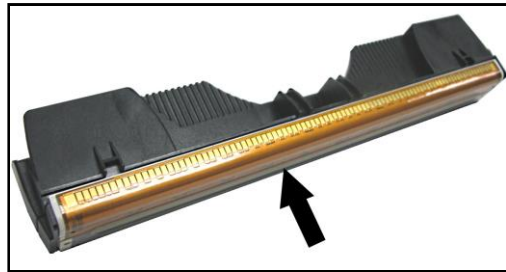

4. Carefully insert Cartridge into compartment at an angle [4], with Printhead surface facing down and Ink Nozzles facing Ink Hoses. Once seated, gently tilt Cartridge back until it snaps into an upright position [5]. DO NOT FORCE Cartridge into position.

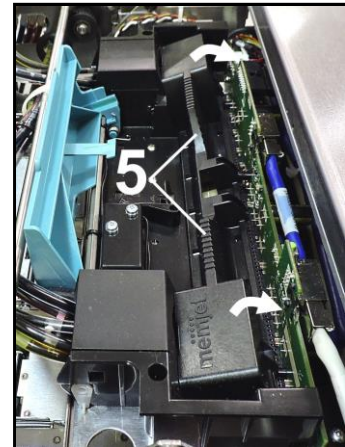
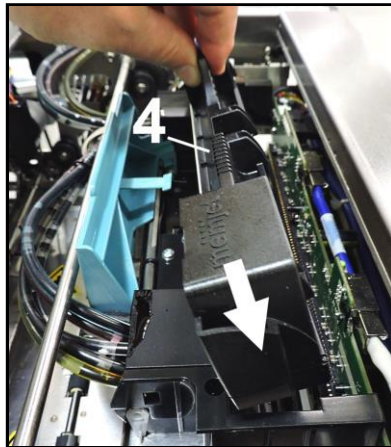

SECTION 2 INSTALLING PRINTER

5. **Close Printhead Latch [6].** Close the Top Cover. Printer starts up and primes ink into the Printhead (*this may take a few minutes.*) **NOTE:** When priming stops, open the Top Cover and check that ink is flowing through hoses. If air bubbles appear, tap lines and close the Top Cover. Or close the Top Cover and click **“Circulate Ink”** on the Touchscreen to clear the air bubbles.

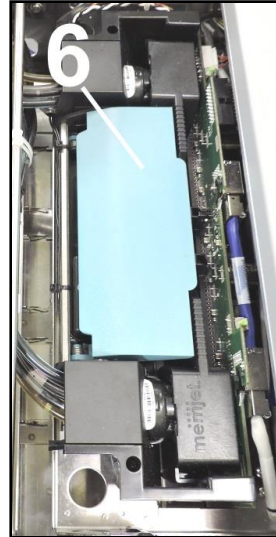

6. **Watch the Control Panel Touchscreen.** Check that the Printhead icon [7] in the Printer image is primed (*solid color*).
7. When **ONLINE [8]** appears, the Printer is ready for use. **NOTE:** If the Printhead icon continues to display an outline or a question mark (?) try the following procedures:

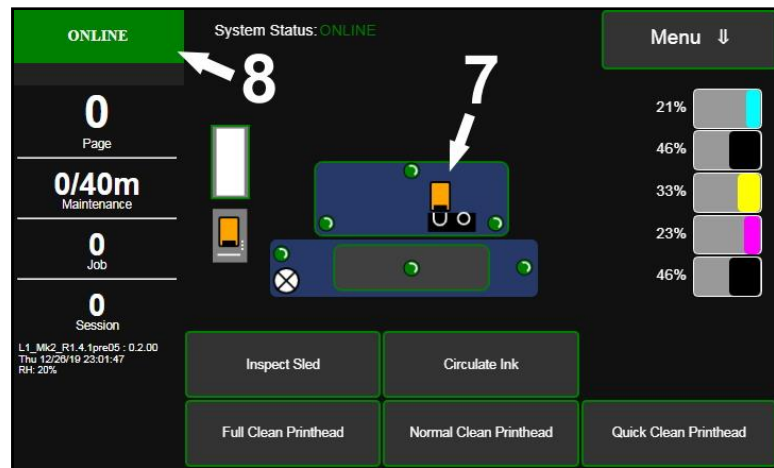

[1] **Printhead icon shows an outline (Printhead unprimed):** Click **“Circulate Ink”** under **“Maintenance”** drop-down in Printer Toolbox.

If issue persists, try the **“Install Printhead”** procedure again. If this does not clear up the issue, contact technical support.

[2] **Printhead icon displays a question mark (Printhead not recognized):** Try the **“Install Printhead”** procedure again. If the issue continues, contact technical support.

NOTE: Printer may take up to 12 minutes to set itself up during initial startup. This is normal.

Connect Printer to External Device

WARNING!

HAZARDOUS MOVING PARTS!
KEEP FINGERS AND OTHER BODY PARTS AWAY!

CAUTION

MAKE SURE THAT PRINTER IS TURNED OFF
BEFORE CONNECTING AN EXTERNAL DEVICE.

Connect to External Device (Winder, Laminator, Dryer, etc.):

Connect one end of the interconnect cable into the 9-pin connector port on the Printer [1] (located just below the USB port).

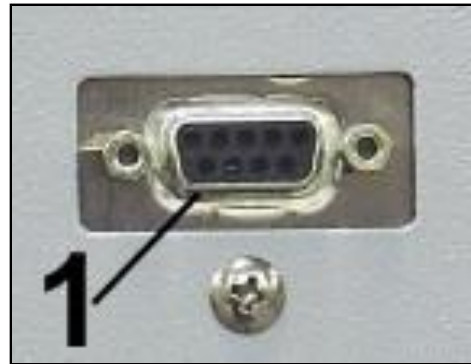

Load Media

Setting the Adjustable Media Sensor:

For irregular-shaped media (*such as a circle*), loosen the Sensor Reflector knob.

Slide the Sensor Reflector along the track so the straight edge of the Sensor [A] aligns with the leading tip of the media [B]. Tighten the knob to lock the Sensor Reflector in place.

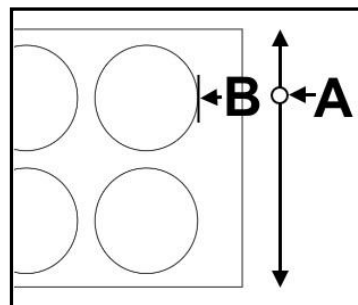

Roll-to-Roll Label Printing

Make sure the Unwinder and Rewinder are properly connected and turned ON (see instructions below). Proper alignment of the Unwinder, Printer and Rewinder is critical to operation of the Label Printer. Position the Printer on a sturdy, level work surface with enough room to place the Unwinder and Rewinder at either end.

Roll-to-Cut Label Printing

Make sure the Unwinder is properly connected to the Printer and turned ON. The winder should be turned OFF and moved out of the way. Proper alignment of the Unwinder and Printer is critical to operation of the Label Printer. Position the Printer on a sturdy, stable level work surface with enough room to place the Unwinder at the feed end of the Printer.

Connecting the Unwinder and Rewinder

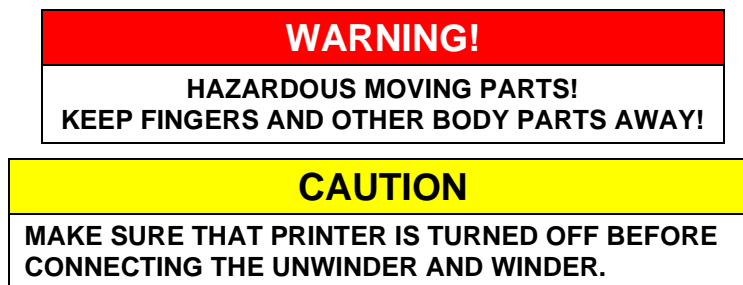

The Unwinder and Rewinder units are identical. Their position relative to the ColorMaxLP2 and their setup determines whether they unwind or rewind.

See pages 12 – 16 for setup diagrams and instructions.

NOTE: When in START (run) mode the Unwinder/Rewinder will automatically turn clockwise or counter-clockwise, based on the position of the Tension Arm. When the end of the label web is reached, the Tension Arm will drop and the device will automatically STOP after about 4 seconds.

Please make sure there are no obstructions that would prevent the Tension Arm from dropping to the Alignment Plate surface when the end of the label web is reached. If an obstruction keeps the Tension Arm from dropping all the way, the device will NOT automatically STOP.

CAUTION: Set device to STOP mode (LED OFF) or Turn OFF (0) the Power Switch before installing/removing or threading labels.

Configuring the unit as an Unwinder:

1. Position unit on left (infeed) side of ColorMaxLP2, and connect the power plug to the back of the unit.
2. Set the power switch to the ON position.
3. Press the Left Arrow button (<<). The Left Arrow LED will illuminate as shown below.
4. Press the Start/Stop button  to start and stop the Unwinder.

START (run) = LED ON

STOP = LED OFF

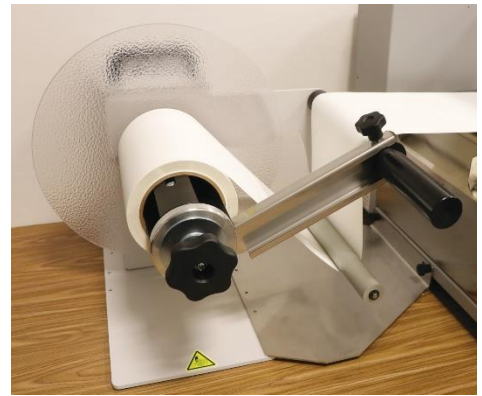

Configuring the unit as a Rewinder:

1. Position unit on right (outfeed) side of ColorMaxLP2, and connect the power plug to the back of the unit.
2. Set the power switch to the ON position.
3. Press the Right Arrow button (>>). The Right Arrow LED will illuminate as shown here.
4. Press the Start/Stop button  to start and stop the Rewinder.

START (run) = LED ON

STOP = LED OFF

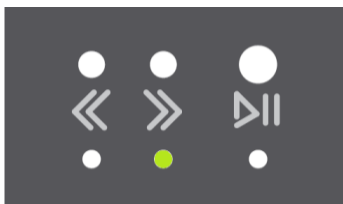

SECTION 2 INSTALLING PRINTER

Loading Labels

Roll-to-Roll Printing

IMPORTANT! Make sure the Unwinder is connected to the Printer.

Printer is equipped with one Adjustable Side Media Guide. Make sure the Unwinder is set to “Auto” and the Winder (*if used*) is turned OFF and that both are connected to the Printer via appropriate ports.

UNWINDING LABELS (device located on left side of printer)

1. Set the unwinder’s Power Switch to OFF (0).
2. Turn the Knob, located at the end of the Quick-Chuck, counter-clockwise to reduce the outer diameter of the Chuck.
3. Slide the full, unprinted label roll over the Quick-Chuck on the shaft until the label roll is against the inner Flange Plate.
4. Turn the Knob, located at the end of the Quick-Chuck, clockwise to increase the outer diameter of the Chuck until the label roll is held securely by the Quick-Chuck.
5. Feed the label web from the label roll, under the Tension Arm and over the Black Shaft.
6. Feed the label web into the entrance end of the printer.
7. Set the unwinder’s Power Switch to ON (1).
8. Press the Left-Arrow button.
9. Press the START/STOP button.

START/STOP  and Left-Arrow LED Indicators should be ON at this time, as shown here.

The Unwinder will automatically move in the correct direction (clockwise or counter-clockwise) based on the position of the Tension Arm. Do not change the direction of the Arrow button.

10. Position the Label Guide against the side of the label roll and label web as shown in the picture below (highlighted in blue).

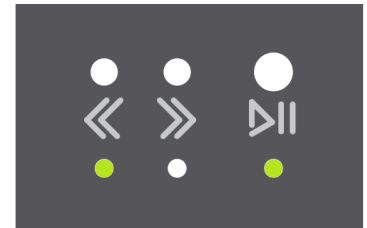
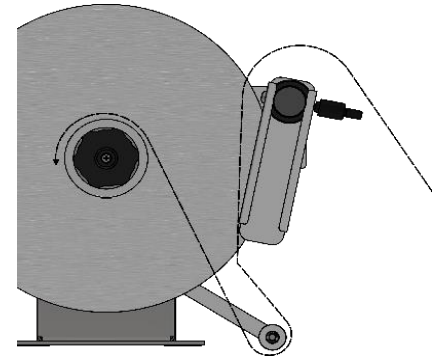

REWINDING LABELS (device located on right side of printer)

1. Set the Rewinder's Power Switch to OFF (0).
2. Turn the Knob, located at the end of the Quick-Chuck, counter-clockwise to reduce the outer diameter of the Chuck.
3. Slide the full, unprinted label roll over the Quick-Chuck on the shaft until the label roll is against the inner Flange Plate.
4. Turn the Knob, located at the end of the Quick-Chuck, clockwise to increase the outer diameter of the Chuck until the label roll is held securely by the Quick-Chuck.
5. Feed the label web from the printer over the Black Shaft, go under the Tension Arm and secure it to the take-up roll core with tape. Then rotate the take-up reel a couple of turns to help secure the label web to the core.
6. Feed the label web into the entrance end of the printer.
7. Set the Rewinder's Power Switch to ON (1).
8. Press the Right-Arrow button.
9. Press the START/STOP button.

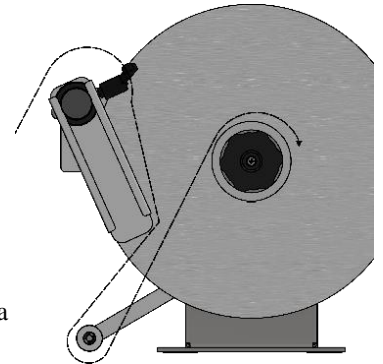

START/STOP  and Right-Arrow LED Indicators should be ON at this time, as shown here.

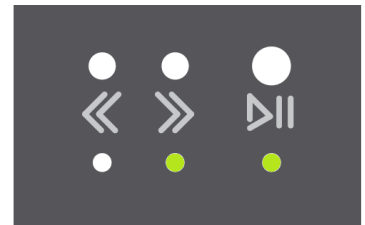

The Rewinder will automatically move in the correct direction (clockwise or counter-clockwise) based on the position of the Tension Arm. Do not change the direction of the Arrow button.

10. Position the Label Guide against the side of the label roll and label web as shown in the picture below.

RECALIBRATING UNWINDER/REWINDER

The Unwinder/Rewinder should automatically stop turning, about four seconds after it runs out of media, and the Tension Arm drops down and rests on the Alignment Plate.

If the Unwinder/Rewinder continues to run, please follow the calibration process provided below.

Calibration of Tension Arm Resting Position (out of material position):

1. Assemble Rewinder/Unwinder as described in User Guide
2. Make sure Tension Arm is resting on Alignment Plate.
3. Turn on Unwinder/Rewinder while holding down the Left Arrow key (key farthest from Start/Stop button).



SECTION 2 INSTALLING PRINTER

Roll-to-Cut Labels

IMPORTANT!

Rewinder must be turned OFF or disconnected from Printer and moved out of the way.

Load the Label Roll on the Unwinder and Printer using steps in Roll-to-Roll Printing above. Then press the **Print** button momentarily so the Printer will align and pull in the labels.

Printing Fanfold Labels

IMPORTANT!

Make sure both Unwinder and Rewinder are turned OFF or disconnected from Printer and moved out of the way.

Loading Fanfold Labels:

1. Place the Fanfold Labels label-side up next to the feed end of the Printer.
2. Feed the Labels under the Brush and into the Printer, aligning the left-side edge with the alignment pins on the Printer. Feed the Label end into the Print Engine.
3. Slide the Adjustable Side Guide so it just touches the right-side edge of the labels.
4. Press the **Print** button momentarily and the Printer will align and pull in labels. Hold the **Print** Button down to feed about 30" (75 cm) of media through the Printer.



Bleeds

Bleeds – See “Appendix C – Borderless Printing: Overspray vs. Oversize”.

SECTION 3 – *Operating Printer*

Once the **Printer Driver** is installed and the Printhead is primed, you are ready to start printing. Set up your job and send it to the Printer. The Printer will start and print.

Set the **Printer Driver** installed in **Section 2** as the default driver. It is then accessible through your applications (such as *Microsoft Word*). Other types of applications and database management software will work in a similar manner when using this Driver.

Printer Driver Properties

The Printer Driver works the same as any other Printer Driver for Windows. It does have some enhancements to help maximize the Printer's ability to print variable addressed pieces quickly and efficiently.

Windows 8, 8.1, and 10: Once job is set up, click **File**, then **Print**. Window at right opens. Make sure the **L Series Driver** is the selected Printer. Clicking **Printer Properties** opens “**General**” Tab window.

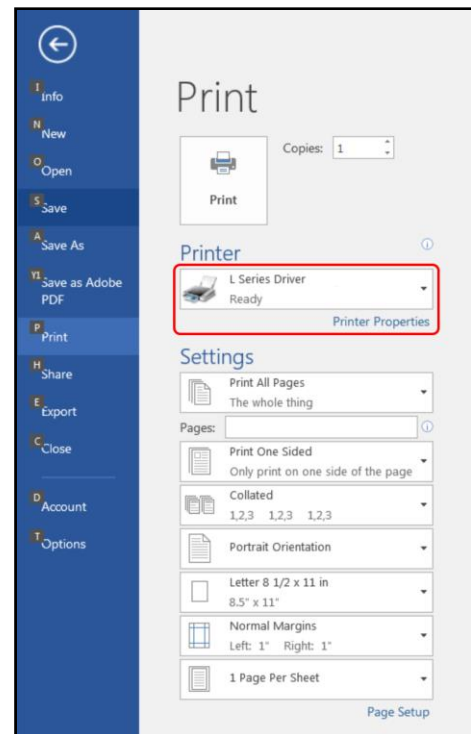

SECTION 3 OPERATING PRINTER

General Tab

General tab lets you select:

- **Orientation** – Set print direction as Portrait (*default*), Landscape, Rotate 180° and Mirrored.
- **Job Management** – **Stitch** is for printing on continuous media (*no gaps*).
Buffer loads entire print job before printing starts.
Mask Optimization (*checked is default*) optimizes images for printing in most applications.
NOTE: Some applications (*like FlexMail*) may display image boundaries when printed. Unchecking **Mask Optimization** box eliminates these lines. (*Remember to check box when changing applications.*)
Printer Capture – When selected, the Printer stores the print job in the Printer **Job Library** after the job is printed.
NOTE: The **Stored Jobs** button on the Printer Touchscreen accesses the **Job Library**.
PC Capture – When selected, saves a Print File (*.prn) on the PC (C:\Windows\Temp) for later use. (*Unchecked is default.*)
NOTE: Use the box below the selection to name the file; otherwise the Printer assigns the current date and a numerical name.
- **Copies** – Enter number of copies to be printed.
Reverse Order: When box is checked, the job will start printing from the last page of a document and end on the first page.
Collate: When printing multiple copies of multi-page documents, checking the box allows all pages of the document to be printed in proper order before printing the next copy.
- **Media** – Adjusts Printer for media being used for a job.
Ink Type: Displays ink type this model Printer is configured for: VersaPass DG or VersaPass DN.
Type: Choose type of media to be used. See list at right.
Size: Set a different size media than document was originally designed for. Document is automatically resized to fit new media.
Borderless Printing: Checking this box allows printing to edge of media (*borderless*). See “**Appendix C – Borderless Printing: Borderless Print vs. Oversize**”.
- **Custom Size** lets you create and save a **Custom Size** to suit your needs.
- **Color Selection** – Set Printing for Color, Composite Black (*uses all colors to print Black*), or Black Only (*uses only Black ink*).
- **Print Quality** – Select **Normal** or **Best**. **Normal** is 1600 x 800 dpi. **Best** setting is 1600 x 1600 dpi, for use when high quality images are required. “**Speed**” allows you to adjust the Printer speed for the media being used (*i.e., slow the printing speed for higher quality on glossy stock*).
- **My Print Settings** – Access saved custom print settings for various jobs.

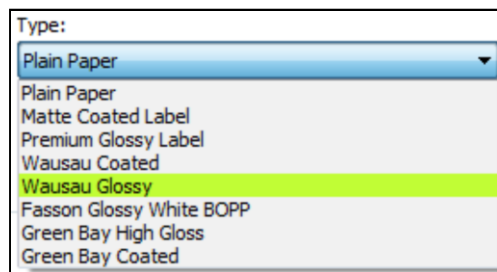
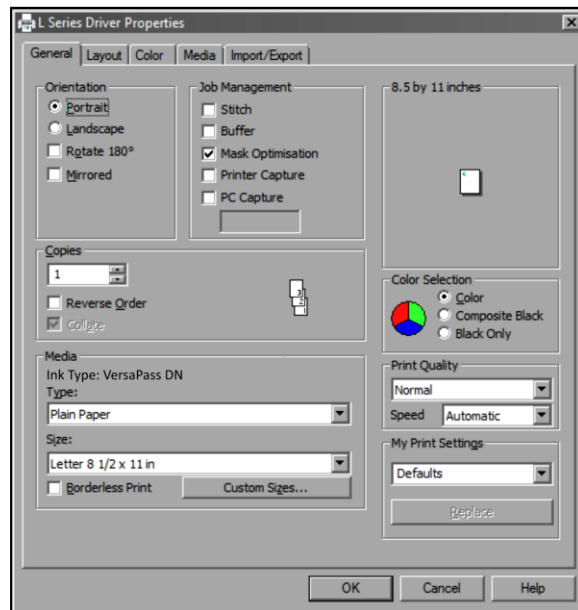

Layout Tab

Layout allows you change how the document prints without changing the original document.

- Resizing** – Specify **Original Size** or **Custom Resize**: Resizes original as a % of normal size. Printer prints document in size you selected regardless of paper size selected.
Print on: Specify a particular size of paper to print on regardless of size of original document. Checking **“Scale to Fit”** automatically resizes document to fit on new page size.
- Watermark** – Prints a light background watermark in paper while printing original document. When selected, **“First page only”** option prints watermark on first page, but not subsequent pages, unchecking prints watermark on all pages.
Custom button lets you create a new watermark or edit an existing watermark, including font selection, color, size and printing angle.

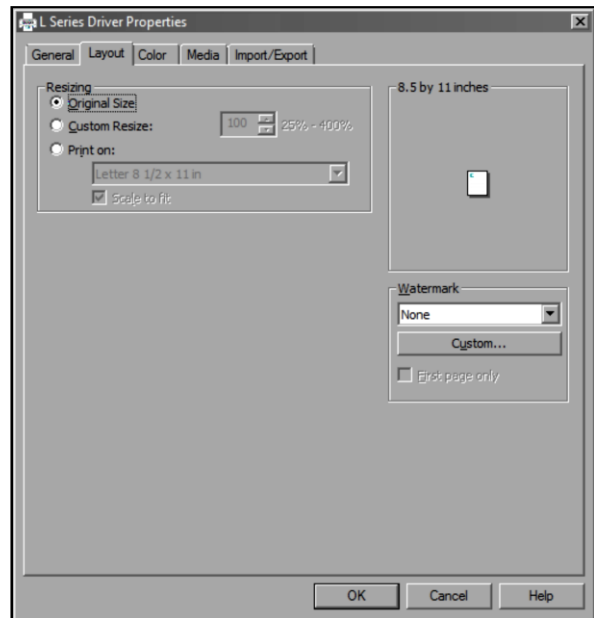

Color Tab

Color is used to adjust the color output of the Printer. Use the sliders to adjust **Color Tone**, **Brightness** and **Saturation**. The **C, M, Y, K** sliders adjust individual colors. Use **Defaults** to reset to **0** settings.

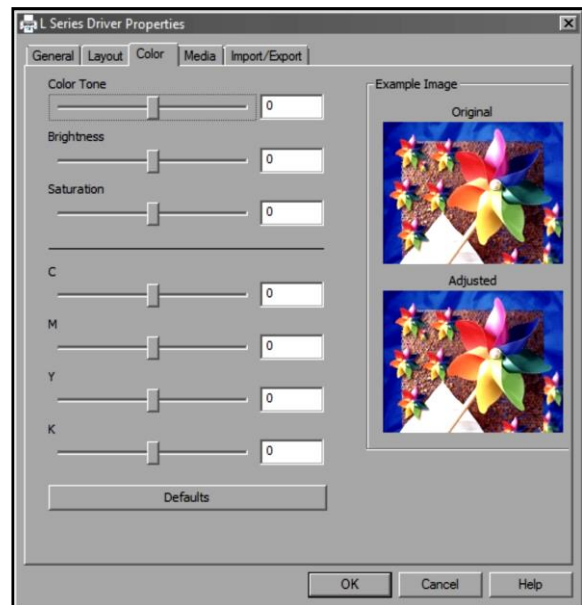

SECTION 3 OPERATING PRINTER

Media Tab

Media Tab shows the the type of media the Printer is configured to run and allows minor changes to the positioning and cutting of the media.

- **Media** – Displays the type of media currently selected for the Printer. Press **Refresh** to update the display.
- **Printing Adjustments** – (*Top, Left and Bottom Adjustments plus Max Page Width and Interpage Gap.*) Make minor positioning changes to the print area in relation to the media if needed.

NOTE: Printing Adjustments only works when Print Area is less than full print width (less than 8.5"/215.9mm wide). See “Using Media Tab Printing Adjustments” on next page.

Stitch – When selected, prints the entire document as a single page (*no gaps*).

Label Frequency – Allows Printer to ignore a set number of gaps between labels. This is particularly useful when the labels are different shapes and the Printer sensor may not sense the edge of second label correctly. (*For example, printing both front and back bottle labels in one pass.*) A label frequency of “1” reads the gap between every label. A setting of “2” will ignore the gap between the two labels [A]. (*In effect, the Printer “sees” the two labels as one label*). The **Label Frequency** can be set from 1-8.

NOTE: Using this feature requires that the job be set up as one label in the layout software, so dimensions (including gap) must be accurate.

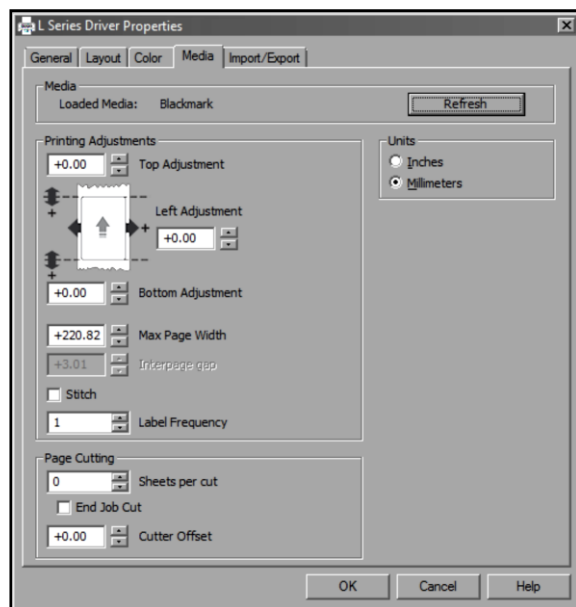

Example of a Label Frequency of “2”

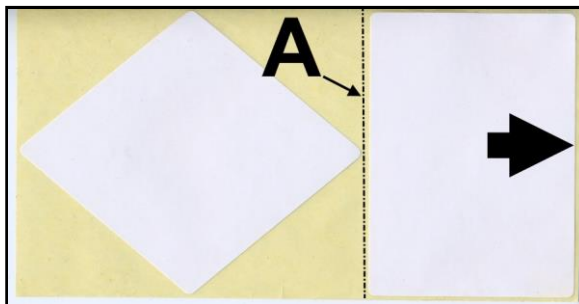

- **Page Cutting – Sheets per Cut:** Set the number of labels (*sheets*) between cuts. **Example:** 1 = cut after every label. 5 = cut after every fifth label. **NOTE:** Since **End of Job Cut** will also be active, last cut may have fewer labels than set **Pages per Cut** number depending on total number of labels you are printing (*i.e. you print a total of 23 labels set to cut after every fifth label, you will have 4 sets of 5 labels, 1 set of 3.*)
End Job Cut: When checked, cuts the end of the media after the job finishes printing.
Cutter Offset: Allows fine tuning of the cut line position after making image positioning adjustments.
- **Units** – Set measurements to be in Inches or Millimeters.

Using Media Tab Printing Adjustments

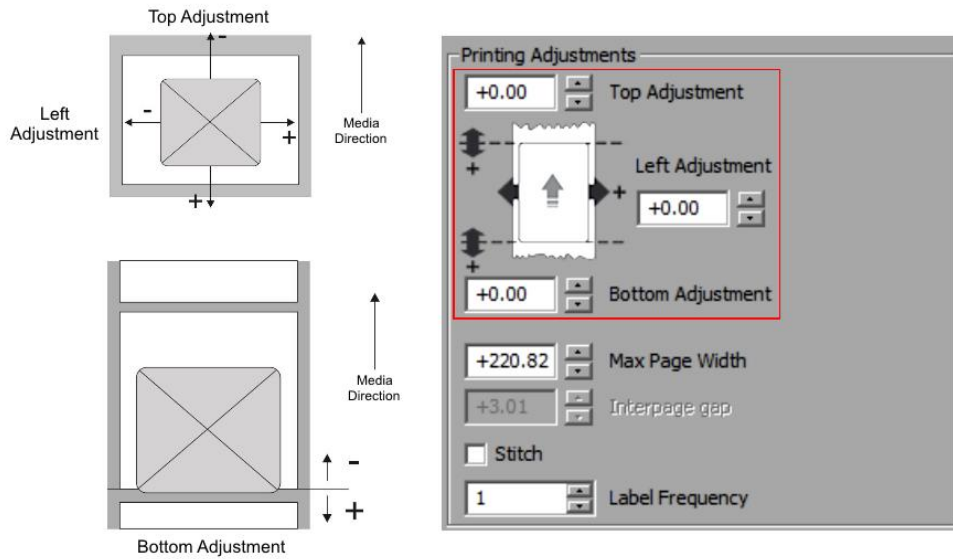

Top Adjustment /Top of Form (TOF) – Moves the image up or down (*-5mm up to +200mm down*) from the top left corner of the media used.

Left Adjustment moves the image area away (*-3mm left to +200mm right*) from the left edge of the media. (*0.1mm increments*)

Bottom Adjustment/Bottom of Form (BOF) – Extends BOF (*in 0.1mm increments*) to allow printing over the edge of a label; (*full bleed label printing*).

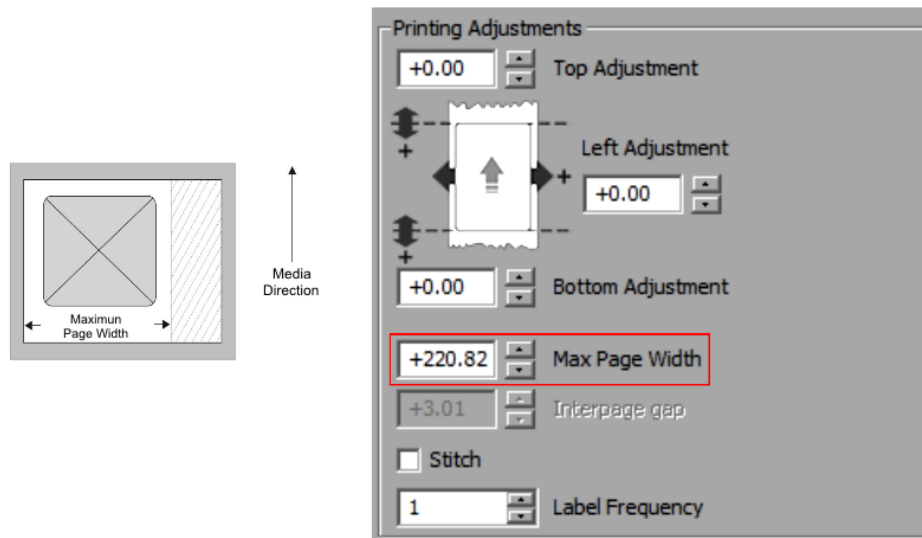

Max Page Width – Sets the width of the actual print area. (*0.1mm increments*) This shuts off nozzles in the non-printing area (*not used for printing*) and saves ink.

NOTE: Can be no larger than the maximum print width for the Printer (8.5"/215.9mm).

Interpage Gap – Sets a gap between labels (*pages*) when using continuous media.

NOTE: Minimum gap (default) is 3mm.

SECTION 3 OPERATING PRINTER

Import/Export Tab

Import/Export is used to preserve any custom **Watermarks, Media Sizes, and/or Print Settings** you may have developed and saved for various jobs when you update Printer firmware.

- **Export** – Send custom settings to a holding file before downloading new firmware.
- **Import** – Return custom settings after firmware installation is complete.

The **Import/Export** tab is also used to import custom media size packages or watermarks from your dealer if they are available.

IMPORTANT!

BEFORE UPDATING ANY PRINTER FIRM-WARE, REMEMBER TO FIRST EXPORT ANY CUSTOM MEDIA SIZES, WATERMARKS OR PRINT SETTINGS YOU HAVE ADDED TO AN OUTSIDE HOLDING FILE. THIS PREVENTS THE LOSS OF YOUR CUSTOM SETTINGS.

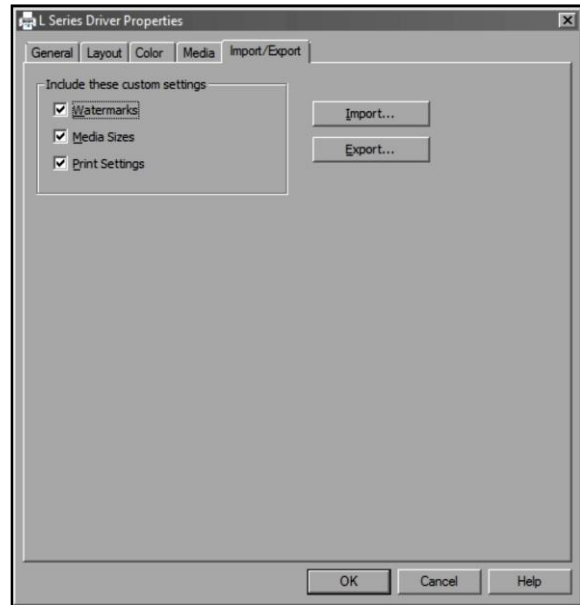

Using Printer Touchscreen

Once the **Printer Driver** is installed, and the Printer is turned ON, you can use the **Printer's Touchscreen**. You can check Printer status, monitor ink usage, perform diagnostic checks, print reports and run maintenance tasks on the Printer from the Touchscreen. **NOTE:** These functions and more can also be operated remotely from a computer using the **Printer Toolbox**. See “Using the Printer Toolbox” following this section.

Tap the screen to view the **Printer Touchscreen**.

- [A] System Status Indicator (at top of screen)
- [B] Drop-Down Menu Options (at top of screen)
- [C] Check Printer Status (across middle of screen)
- [D] Three often-used control buttons (at bottom of screen)

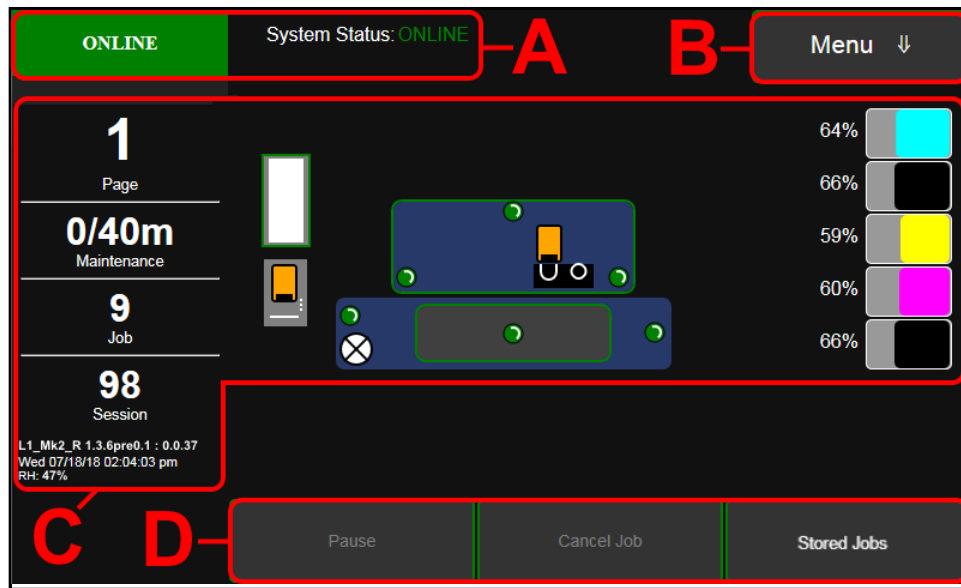

Drop-Down Menu Options

The **Menu** drop-down gives you nine selections: **Job, Setup, Test Print, Maintenance, Paperpath, Media Scan, Wiper, System Test** and **Videos**. **NOTE:** “Videos” is only available when MP4 video files are loaded on the Printer.

Videos	Job
	Setup
	Test Print
	Maintenance
	Paperpath
	Media Scan
	Wiper
	System Test

SECTION 3 OPERATING PRINTER

Job (Status Screen)

The opening screen provides information about the status of the Printer.

Status Indicator box shows Printer activity as **ONLINE**, **ERROR**, **MAINTENANCE**, **PRINTING** or **PAUSED**. The gray box (*below Status Indicator*) shows the name of the job being processed.

System Status displays current status of the Printer and/or error message.

Page shows the page count for a given job.

Maintenance counts down from a specified preset length of printed media until the next automatic Printhead maintenance is performed by the Service Station. **NOTE:** Select the length by opening the Printer Toolbox **User Interface** screen, **Mid-Job Servicing**. In this example, service is performed every 40 meters (131-ft.).

Job shows number of jobs printed (*resettable*), **Session** shows the total number of pages printed by the Printer (*resettable*) over the length of a Session (*shift, day, week, etc.*).

Firmware: UI Version displays the current firmware and UI firmware (*Touchscreen*) versions currently installed on the Printer.

Date and Time shows current date and time. These can be configured and set by opening the **Service** screen, then **Network Config**, then **Date and Time**.

Relative Humidity (RH) displays the current ambient humidity detected near the Printer. **IMPORTANT:** The RH % on the screen enlarges and blinks if the Relative Humidity consistently falls below 30%. To set the Printer for low humidity conditions see “Using the Printer Toolbox, User Interface, Low Humidity”.

Printer Messages may appear under **RH (Relative Humidity)**.

Media Icon: Displays the type of media the Printer is currently configured for – **Continuous**, **Diecut** or **Black Mark**. Set the type of media by tapping the icon and selecting the appropriate media type or using the **Media Scan** function after selecting **Service** from the **Menu** dropdown.

Printhead Height Icon: Shows the current Printhead printing height setting. (*3 dots = Low, Normal, High settings*) Set on the Toolbox **User Interface** screen, **Print Height**.

Printer Icon: Shows the status of the **Media Sensors** located in the media feed path of the Printer. Also shows the status of the Ink Valves, Service Station, and Printhead. These can alert the operator to the type and location of a problem. (*See icon key above.*) Tapping any of the status icons pops up a description of that icon.

Ink Levels displays percentage of ink remaining in each of the Ink Tanks.

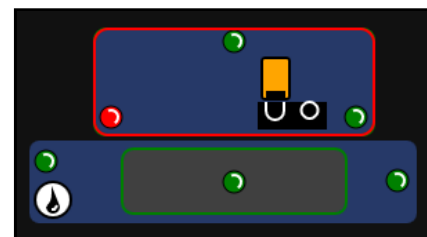
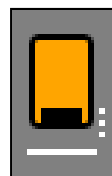
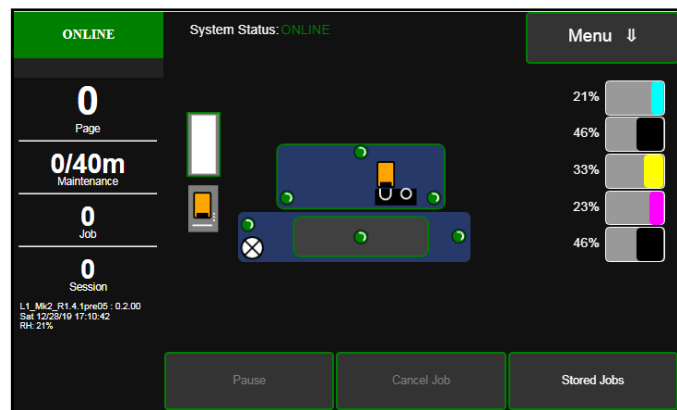

ONLINE	Ink Valves	Service Station
ERROR	<ul style="list-style-type: none"> Open Ink Closed Open Air Unknown 	<ul style="list-style-type: none"> Wipe Print Cap Unknown
MAINT	Sensors	Printhead
PRINTING	<ul style="list-style-type: none"> Uncovered/Closed Covered/Open 	<ul style="list-style-type: none"> Present-Primed Present-Unprimed Unknown
PAUSED		

CONTROL BUTTONS

(located along the bottom of the screen): Provide quick access to often-used functions.

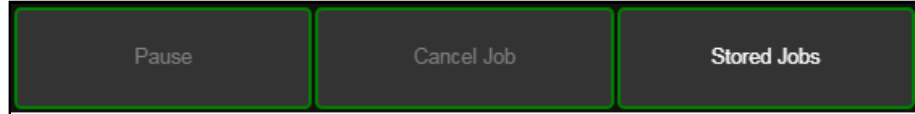

Pause: Tap to temporarily stop printing. Tap again to resume printing.

Cancel Job: Cancels a paused job from the printing queue. **Cancel** is unavailable unless the **Pause** button has been pressed first. **NOTE: Cancelled jobs must be reloaded before printing can resume.**

Stored Jobs: Opens the Printer's **Job Library** to access print jobs saved in the Printer's memory. You can also make changes to the job specifications and delete jobs as needed. See **“Using Stored Jobs”** below.

NOTE: If no jobs are saved on the Printer, this button will be inactive.

Clear Error: Click to clear error messages after a Printer problem is resolved (i.e., after clearing a paper jam).

Using Stored Jobs (Print Job Library)

Print jobs can be saved to the Printer's **Job Library** by selecting the **Printer Capture** option under **Job Management** on the **General Tab** of the **Printer Driver**.

You can access jobs saved in the Printer's **Job Library** using the **Stored Jobs** button on the **Jobs Screen**.

NOTE: If no jobs are saved on the Printer, this button will be inactive.

To view the Printer's **Job Library**, press **Stored Jobs** on the **Jobs Touchscreen**. The **Jobs Library** opens.

Use the **View** button [A] to change the Library view from Icon to List.

Use the **Search** icon [B] to search for a particular print job.

The **Exit** button [C] returns you to the **Jobs (Status)** screen.

The **Printer** icon [D] prints the selected job.

The **Trashcan** icon [E] (*List view only*) deletes selected job(s) (*checked in the Delete column in the Jobs List*) from the Library.

The **Disk** icon [F] displays the available space left in the Printer's Job Library memory.

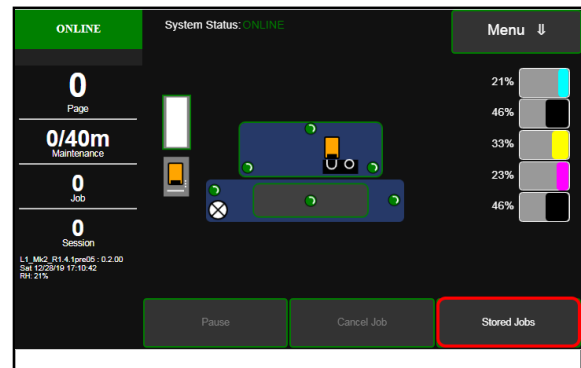

List View

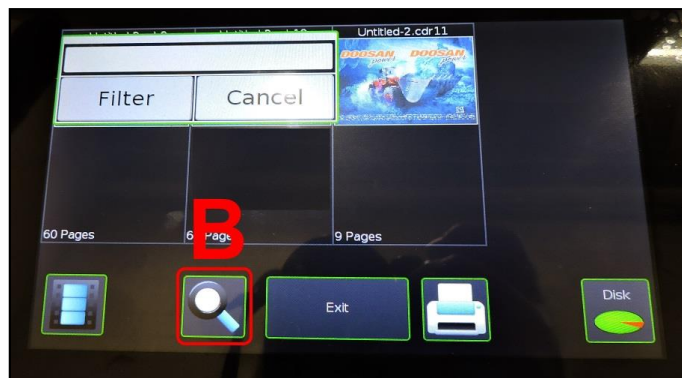

Search Screen

SECTION 3 OPERATING PRINTER

Select a job by tapping the job icon or the list name. The **Job Print Options** screen opens.

The (4) **Control** buttons let you **Exit**, **Print**, **Save** or **Delete** the print job. The **Save** button saves any changes you make to the job specifications in the **Print Options** on the right side of the screen. If you do not tap **Save**, the print job reverts to its original settings when you **Exit**.

The **Print Options** allow you to change or adjust print specifications for the print job. Scroll down the screen to access all options.

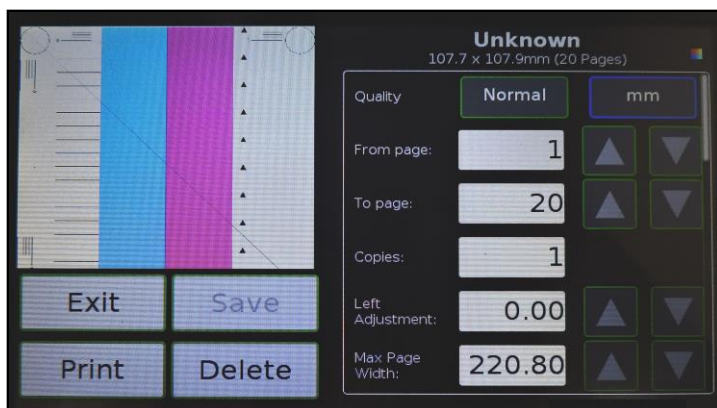

Quality – Tap the button to select **Normal** or **Best**. **Normal** is 1600 x 800 dpi. **Best** setting is 1600 x 1600 dpi.

mm or inches – Tap the button to change measurements to millimeters or inches.

“From page” and **“To page”** – Select the first and last pages of a job (*or part of a job*) to print using the **Up** or **Down** arrows.

Copies – Enter the number of copies to be printed.

Left Adjustment – Moves the image area away (*-3mm left to +200mm right*) from the left edge of the media. (*Up or down arrows move in 0.1mm increments*)

Max. Page Width – Sets the width of the actual print area. (*Up or Down arrows move in 0.1mm increments*) This shuts off nozzles in the non-printing area (*not used for printing*) and saves ink. **NOTE: Can be no larger than maximum print width for Printer (8.6"/220.8mm)**

Top Adjustment – Moves the Top of Form (TOF) image up or down (*-5mm up to +200mm down*) from the top left corner of media used.

Bottom Adjustment – Extends the Bottom of Form (BOF) (*in 0.1mm increments*) to allow printing over the edge of a label (*full bleed label printing*).

Interpage Gap – Sets a gap between labels (*pages*) when using continuous media. **NOTE: Minimum gap (default) is 3mm.**

End Job Cut – When checked, cuts the end of the media after the job finishes printing.

Sheets Per Cut – Set the number of labels (*sheets*) between cuts.

Example: 1 = cut after every label. 5 = cut after every fifth label.

NOTE: Since **End of Job Cut** will also be active, the last cut may have fewer labels than the set **Pages per Cut** number depending on the total number of labels you are printing (*i.e. you print a total of 23 labels set to cut after every fifth label, you will have 4 sets of 5 labels, 1 set of 3.*)

Normal Speed – Adjust the Printer speed for the **Normal Quality** setting and for the media being used (*i.e., slow the printing speed for higher quality on glossy stock*).

Best Speed -- Adjust the Printer speed for the **Best Quality** setting and the media being used (*i.e., slow the printing speed for higher quality on glossy stock*).

Cutter Offset – Allows fine tuning of the cut line position after making image positioning adjustments.

Label Frequency – Allows the Printer to ignore a set number of gaps between labels. This is particularly useful when the labels are different shapes and the Printer sensor may not sense the edge of second label correctly. (*For example, printing both front and back bottle labels in one pass.*) A label frequency of “1” reads the gap between every label. A setting of “2” will ignore the gap between the two labels [A]. (*In effect, the Printer “sees” the two labels as one label*). The **Label Frequency** can be set from **1-8**.

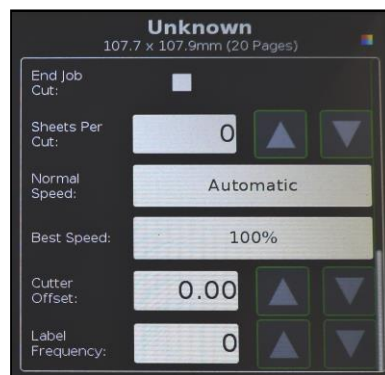

Setup Screen

Tap the **Menu** button, then **Setup** button to open the **Setup** screen.

Release Printhead – Pumps ink back into the Ink Tanks and opens the Printhead Latch to remove or install the Printhead Cartridge.
NOTE: Button is only active if the system is deprimed first.

System Deprime – Pumps ink back into the Ink Tanks prior to replacing the Printhead Cartridge or transporting the Printer.

Network Config button. Click to view, enter or change settings to connect the Printer to your network. You can also set the **Screensaver Timeout** (*sleep delay*) and **Printer Date and Time**. (See also *System Settings in Using Printer Toolbox*.)

Restart – Restarts the Printer without having to perform the shutdown routine (*purging ink tanks, priming, etc.*)

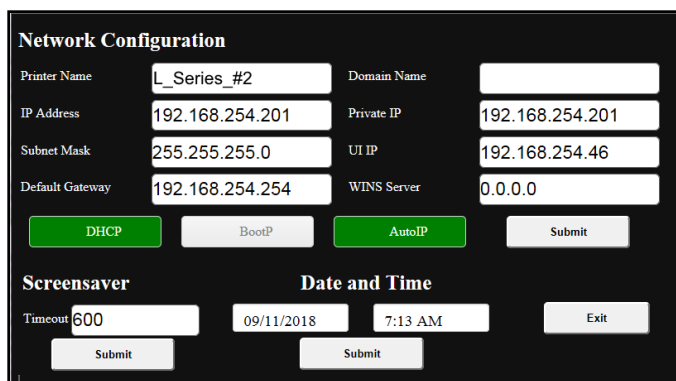
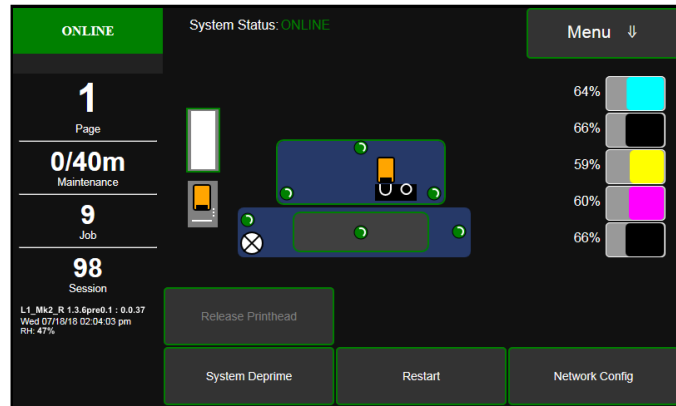

Test Print Screen

Tapping **Menu**, then **Test Print** opens the **Test Print** screen options for printing different reports.

Print Color Bars – Prints a series of 7 color bars (*per Printhead*) to indicate how well the Printheads are mixing colors and printing.

Print Setup page – Prints a printing pattern used for positioning an image on the page.

Print Configuration – Prints the current Printer configuration including Firmware Version, Network Connection, Printer Serial Number and more.

Print Printhead Test – Prints color bands, text and patterns to check the condition of the Printhead's ink nozzles. **NOTE: Uses less ink than “Print Color Bars”.**

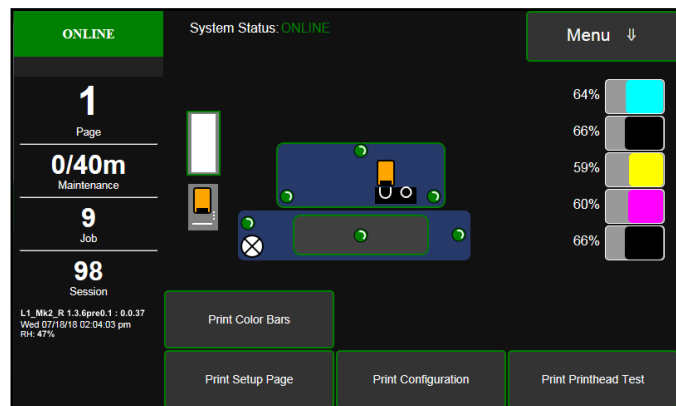

SECTION 3 OPERATING PRINTER

Maintenance Screen

Tapping **Menu**, then **Maintenance** opens the **Maintenance** screen. These buttons operate functions for Printer and Printhead maintenance.

Inspect Sled – Moves the **Service Station** out from under the Printhead Assembly for inspection, cleaning or service.

Circulate Ink – Purges air from ink lines and primes system after replacing the Ink Tanks or the Printhead Cartridge.

Full Clean Printhead – Runs cleaning routine multiple times for the most thorough flushing and cleaning of the Printhead.

Normal Clean Printhead – Runs cleaning and wiping routine twice for a more thorough flushing and cleaning than “**Quick Clean**”.

Quick Clean Printhead – Circulates ink; wipes and cleans the **Printhead Cartridge**.

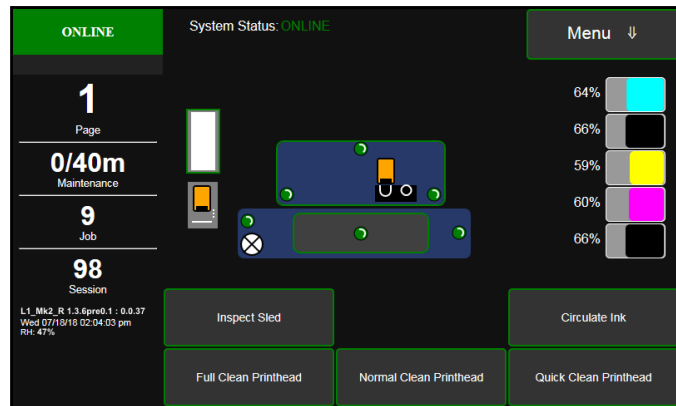

Paperpath Screen

Tapping **Menu**, then **Paperpath** opens the **Paperpath** screen. These buttons are used to move media through the Printer when loading or unloading the Printer.

Unload – Rewinds the media back onto the Unwinder and into the Start position on the Printer.

Cut – Tap to cut the roll. The **Cut** button may change to **Cut Position** – In this instance, pressing the button advances the last printed label past the Cutter, then roll is cut and the media retracts to the Start position.

Load – Moves the media from the Unwinder and into the Start position.

Reverse Arrow – Moves media back onto the Unwinder. Pressing once moves media at slow speed, pressing again moves media at faster speed.

Stop – Stops the media from either advancing or rewinding.

Forward Arrow – Moves media forward through the Printer and onto the Winder. Pressing once moves media at slow speed, pressing again moves media at faster speed.

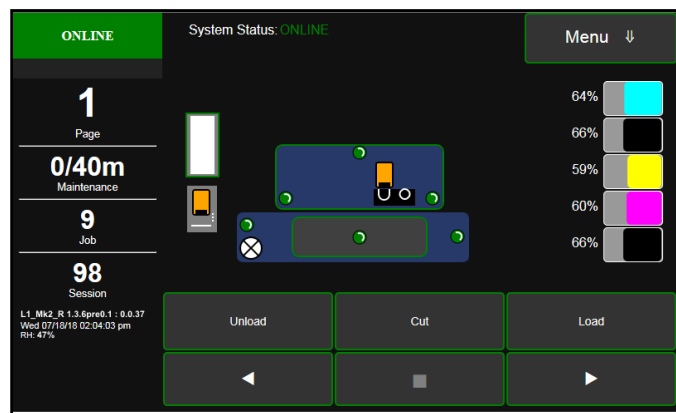

Media Scan Screen

Tapping **Menu**, then **Media Scan** opens the **Media Scan** screen. Use **Media Scan** to fine tune sensor sensitivity and/or adjust scan length if media is not printing correctly, or to determine if a type of media is going to have problems printing. This is generally due to the sensors having trouble differentiating between the label surface and backing/gap. (See *Using Media Scan* below).

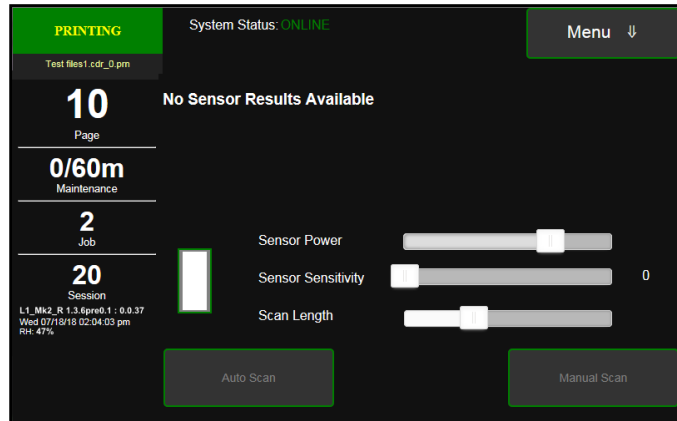

NOTE: If using notched Tags, open the Top Cover and slide the white magnetic strip [A] back to uncover the See-Thru Sensor [B]. Cover the Sensor for all other media.

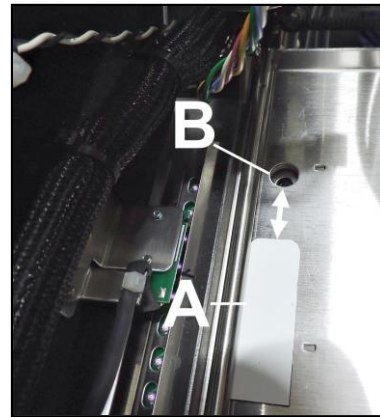

Using Media Scan

1. Tap **Menu**, then **Service** to open the **Service** screen. Tap **Media Scan**.
2. **Media Scan** screen opens. Tap the **Label Icon** to select the type of label being used (*diecut or black mark*).
3. Set the **Scan Length** bar slider (*set in mm in this example*) so the length would include at least 4 or 5 labels.
4. Load media in the Printer.

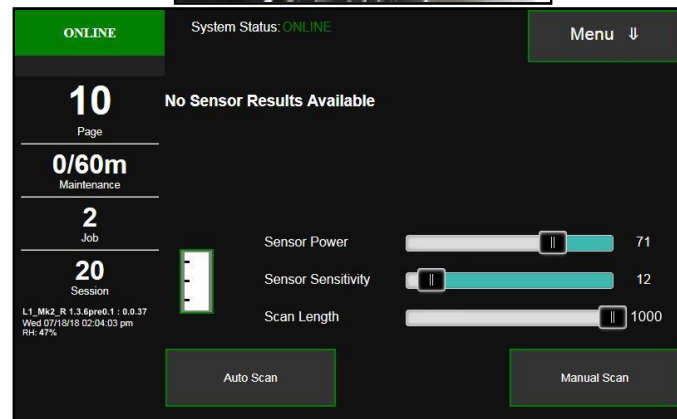

SECTION 3 OPERATING PRINTER

- Tap **Auto Scan**. The Touchscreen will display a graph together with results marked **Legend** and **Edge Distances**.

The **graph** shows the difference between the high points (*gaps/backing*) and flats (*label media*). If there is little difference between the highs and the flats, the Printer may have trouble differentiating the labels from the gaps.

NOTE: Tapping or rolling the cursor over the blue graph line provides readouts of the points on the graph.

Legend: Explains what the graph is showing, **Media**, (*TOF/BOF-Green line*), and **Sensor**, (*Sensor-Blue line*).

Edge Distances:

Top line shows the average gap distance reading. **Bottom line** shows the length of the label reading.

This example uses a 1/8" (3.5mm) black-mark or gap with a 4" (101.6mm) long label.

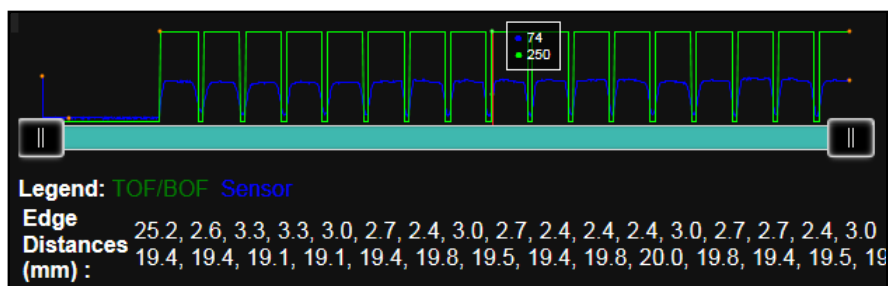
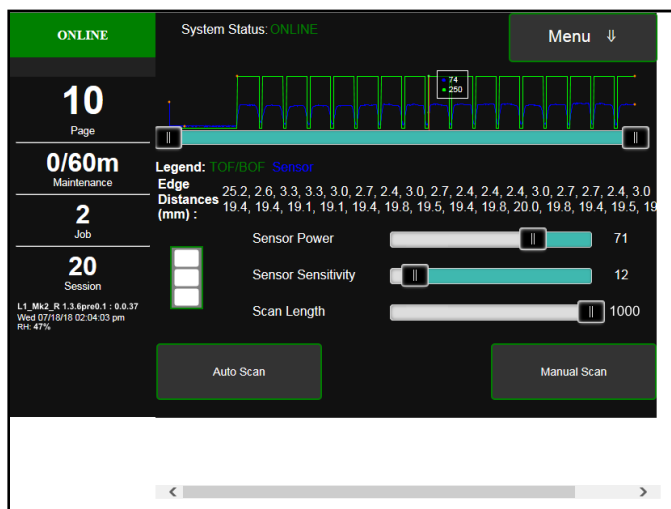

- Manual Scan: For Advanced Users Only.** Use **Manual Scan** if you wish to fine tune the results of the **Auto Scan**. First, make sure that the label type and the selected Touchscreen label icon match. Only the sensors for that type of media will be active. If the label type is different, an **Error** will show on the Touchscreen status box. Adjust the **Sensor Power** and/or **Sensor Sensitivity** sliders in very small increments. You can also increase or decrease the length of media to be scanned by moving the slider on the **Scan Length** bar. Tap the **Manual Scan** button. Repeat as necessary to get the desired result.

Sensor Power: 0 to 100

Sensor Sensitivity: 0 to 100

Scan Length: 0 to 1000mm (0 to 39.4")

NOTE: Media Scan is also available in the **Toolbox** on the computer. (See *Media Scan in Using the Toolbox*).

Wiper Screen

Tapping **Menu**, then **Wiper** opens the **Wiper** options screen. Selections are **Wiper Transfer**, **Condition Wiper** and **New Wiper**.

Wiper Transfer – Manually initiates a **Wiper Transfer** instead of waiting for a Transfer to automatically occur during normal operating cycles. Squeegees excess ink off of the **Service Station Wiper Roller**.

Condition Wiper – Saturates, conditions and cleans the **Wiper Roller** with ink to remove dried residue if the Printer is left inactive for long periods of time.

New Wiper – Moves the **Service Station** out to remove and replace the **Service Station Wiper Roller** or **Wiper Module**. Once the new **Wiper** or **Wiper Module** is installed, the Printer primes with ink to condition the **Wiper** to optimal operating condition. The **Wiper Revolution Counter** also resets to **0**.

1. Press **New Wiper**. The **Service Station** moves out.
2. Open the **Top Cover**. Replace the **Wiper Roller** or **Wiper Module**.
3. Close the **Top Cover**. Printer primes with ink to condition the **Wiper** and the **Wiper Revolution Counter** resets to **0**.

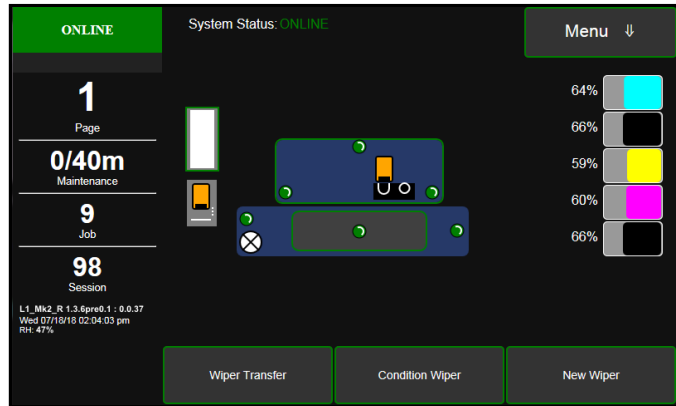

System Test

NOTE: These tests should only be performed by authorized service personnel.

System Test allows testing individual or all Printer systems listed to check that they are operating within specifications. It also allows service people to check the Printer after servicing or replacing parts, particularly belts.

Tap **Menu**, then **System Test** to open the **Password** screen. Enter the password and tap “**Submit**” to open the **System Test** screen.

NOTE: Prior to running the System Test make sure no media is loaded in the Printer and there are no obstructions in the media path.

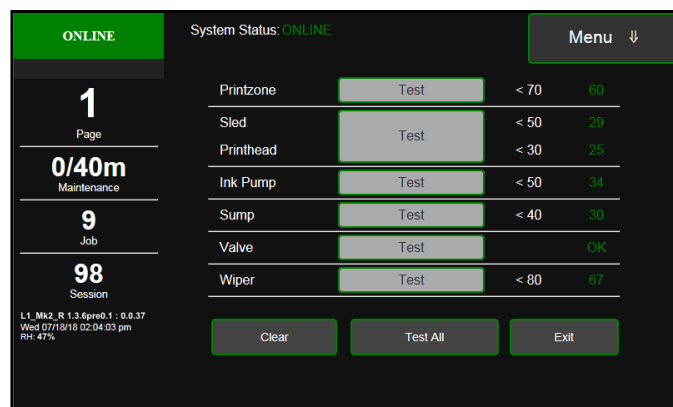
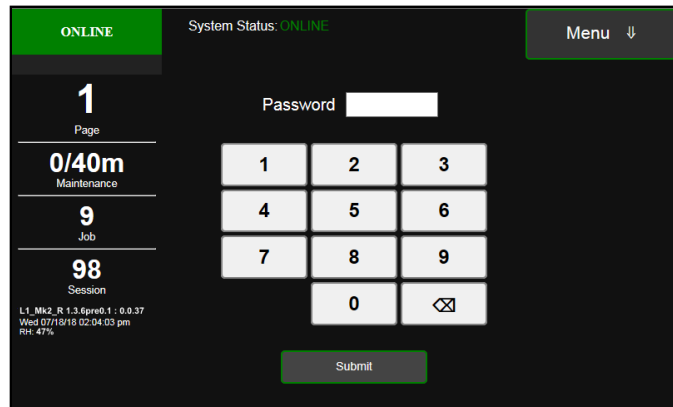

SECTION 3 OPERATING PRINTER

Videos

MP4 video files can be uploaded to the Printer using the **Control Panel USB Port**. Access saved video files by tapping **Menu**, then **Videos**. This opens the **Video Library** screen. **NOTE: "Videos" is only available when video files are loaded on the Printer.**

NOTE: Requires User Interface (UI) firmware version 2.0 or higher.

To load video files: See "Using the Control Panel USB Port" below.

[A] **Video Library Playlist.** Lists all video files available on the Printer. Simply tap a title to play the video.

[B] **Trashcan icon.** Deletes the selected video from the **Video Library**.

[C] **Viewing Mode button.** Switch between **Single play** (*two-way arrows*) or **Continuous Loop** (*circular arrows*).

[D] **Playing Time indicator.** Shows how much of the video has played. The slider selector is also used to forward or reverse a video.

[E] **Stop button.** Stops playing the selected video.

[F] **Play/Pause button.** Pauses or restarts the selected video.

[G] **Exit button.** Returns you to the **Jobs (Status)** screen.

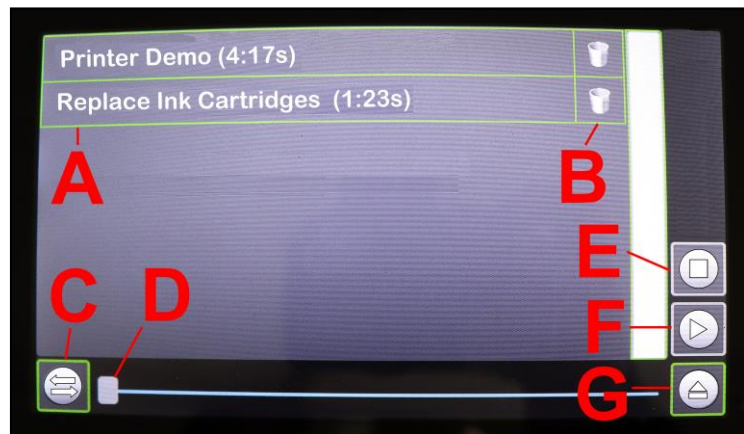
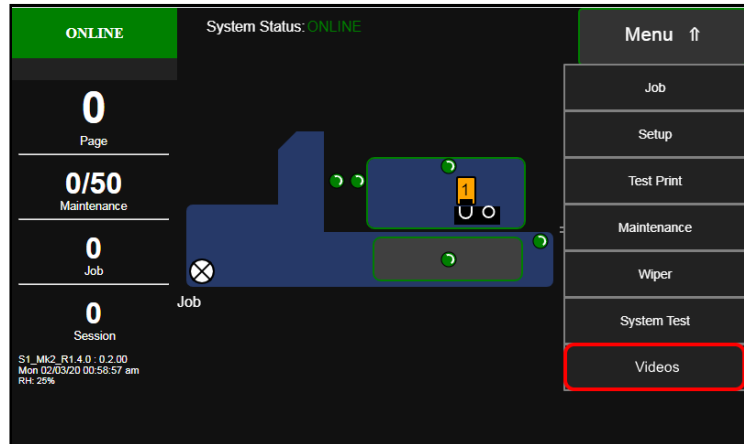

Using the Control Panel USB Port

The USB port, (*located below the Touchscreen*), can be used to backup stored **Print Jobs** and **Debug logs**, upload **Print Jobs**, upload MP4 video files and apply Printer firmware and Touchscreen (UI) updates. Backed-up **Print Jobs** can then be transferred (*uploaded*) to another ColorMaxLP2 Printer. **NOTE: Stored Print Jobs** are jobs that have been saved to Printer's memory. See "Stored Jobs" for more details on saving and using stored **Print Jobs**.

IMPORTANT
DO NOT CONNECT ANY DEVICES OTHER THAN FAT32 FORMATTED USB FLASH DRIVES TO THE PRINTER.

Overview: When a USB thumb drive is inserted into the **Control Panel USB Port**, it is automatically detected and a **USB Management** application opens on the **Touchscreen (UI)**. Select a range of functions via six buttons, depending on what is available on that particular USB Drive.

Green outline: active. **White outline:** inactive or display only.

Important: When finished backing up or uploading, press the **Quit** button and give the system a few seconds to correctly shut down the USB Drive before removing it.

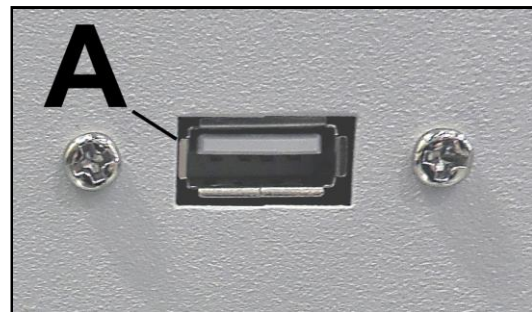

When a FAT32 formatted USB Flash Drive is plugged into the USB port [A] the **USB Management** screen opens:

USB Storage Device Detected:

Displays the Printer you are connected to, and the date and time.

USB: The graph displays the amount of usable memory left on the USB Flash Drive plugged into the Printer.

Backup Logs button: Backs up all of the **Debug Log** files currently on the Printer. There are two groups of logs. Each group is automatically backed up as a zip file located at the top level on the USB drive directory using the following format:

- **Printer Logs:**
Model_SerialNumber_YYMMDDHHMM.tgz
- **System Logs:** Model_SerialNumber_YYMMDDHHMM_syslog.tgz

Log files can be opened/unzipped using a zip file utility.

Backup Print Jobs button: Backs up all of the **Print Jobs** currently stored in the Printer's **Print Job Library** onto the USB drive. They are stored in a directory using the following format:

- prns/Model_SerialNumber_YYMMDDHHMM/job_files

Under the main **prns** directory, the job files are the individual **prns**. There is also a directory of thumbnails associated with each job file.

Upload Print Jobs button: Allows you to copy and transfer Print Jobs between same model Printers. (See **Backup Print Jobs** above). During the upload, the **Printer Model** is checked against the **saved jobs** to ensure the job matches the Printer. **NOTE: Invalid jobs are skipped and duplicate jobs are ignored.** The USB drive's file format is the same as the **Backup Print Jobs** format. This means the job files should be contained in a directory located under a top level directory called **prns**. When **Upload Print Jobs** is selected, the list of directories below **prns** is displayed, allowing you to select which directory to import. All of the valid files in the selected directory are imported.

Upload Videos button: Copy or transfer training or demonstration videos to the Printer. (MP4 files only, this is the only way to upload videos given the size of the files.) Before saving a video to the USB Drive, create a directory on the top level of the USB called **videos**. **NOTE: DO NOT put videos in this folder.** Creating directory levels (folders) under the **videos directory** allows you to save a single video or groups of videos into that folder or folders. When **Upload Videos** is selected, the **videos** directory opens and displays the list of sub-directories (folders) where you have saved individual or groups of video files. You can now select which directory (folder) to import. All **MP4 files** in the selected directory are imported. **NOTE: Requires User Interface (UI) firmware version 2.0 or higher.**

Apply Updates button: Apply **UI (*.rpz format)** and **Firmware Updates (*.fbf format)** directly via the USB Interface. When saving the **UI** and **Firmware Updates** to the USB drive, place them in a directory named **updates** at the top level of the USB drive. When the USB is plugged into the **Printer's Control Panel USB Port**, and the **Apply Updates button** is selected, the files are checked to ensure the update is compatible with the current UI version or Printer Model to avoid applying incompatible updates. To avoid accidentally applying the wrong update, a **Confirmation screen** helps to ensure the correct file is selected. Once an update has been applied, the **UI** will usually reboot. After rebooting, the USB Drive will not be automatically detected. The USB needs to be manually removed and reinserted if more operations are required.

NOTE: Requires User Interface (UI) firmware version 2.0 or higher.

Quit button: Press to exit the **USB Management** screen. Wait a few seconds for the Printer to safely shut down the USB Flash Drive before removing it from the **Control Panel USB Port**.



SECTION 3 OPERATING PRINTER

Using Printer Toolbox

Once the **Printer Driver** is installed, you can access the **Printer Toolbox** remotely from a computer. You can check Printer status, monitor ink usage, perform diagnostic checks, print reports and run maintenance tasks on the Printer from your computer. The **Toolbox** also has a more extensive list of functions not available on the **Touchscreen** and a password protected access to a range of options for qualified service personnel. For **Touchscreen** functions, see “Using Printer Touchscreen” preceding this section. **The Toolbox works with both conventional and touchscreen computer screens.**

To open the Printer Toolbox (from a computer):

Open **Start Menu**; then click on **Toolbox**, select **L Series Driver**:

NOTE: Conventional Screens: Use your cursor. **Touchscreens:** Tap buttons or selections or use your cursor.

[A] System Status Indicator and Drop-Down Menu Options (*at top of screen*)

[B] Check Printer Status (*across middle of screen*)

[C] Three often-used control buttons (*at bottom of screen*)

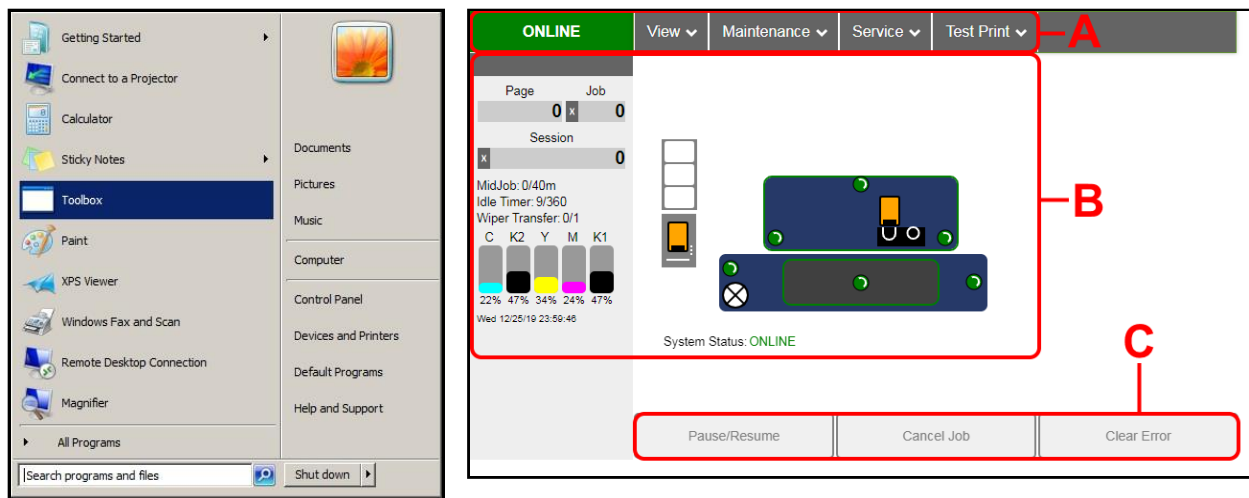

Drop-Down Menu Options

There are four **Drop-Down Menus**:

View, Maintenance, Service and **Test Print**. The drop-down menus are available on every Toolbox

screen allowing you to toggle between menus and select different Printer features and functions.



View Drop-Down

The **View** drop-down gives you four choices:

System Status, User Interface, Ink Usage and **Service Menus**.

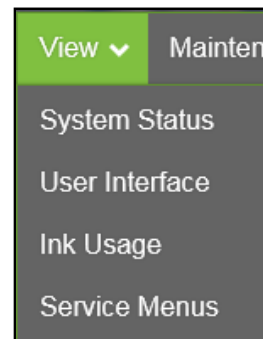

System Status

This screen opens when you access the Toolbox. It provides information about the Printer.

Status Indicator shows Printer activity as **ONLINE**, **ERROR**, **MAINTENANCE**, **PRINTING** or **PAUSED**. The gray box (*below Status Indicator*) shows the name of the job being processed.

Page shows the page count for a given job.

Job shows number of jobs printed (*resettable*),

Session shows the total number of pages printed by the Printer (*resettable*) over the length of a Session (*shift, day, week, etc.*).

Mid-Job counts down from a specified preset length of printed media until the next automatic Printhead maintenance is performed by the Service Station.

NOTE: Select the length by opening the Printer Toolbox **User Interface** screen, **Mid-Job Servicing**. In this example, service is performed every 40 meters (131-ft.).

Idle Timer shows in minutes how often maintenance will run when Printer is not running. Minutes are settable on the **User Interface** screen, **Idle Timeout (min)**.

(**Example:** 9 = idle minutes elapsed. 360 = Preset amount of minutes the Printer has to be idle before automatic maintenance is performed.)

Wiper Transfer shows how often a **Wiper Transfer** (*cleaning excess ink from the Service Station roller*) will be performed in relation to when **Wipe Printhead** or **Printhead Cleaning** is performed. (**Example:** 3/1 = Printer performs 3 **Wipe Printheads** before one **Wiper Transfer** is performed.)

Ink Levels displays percentage of ink remaining in each of the Ink Tanks.

Date and Time shows current date and time. These can be configured and set by opening the **Service** dropdown screen, **System Settings, Date and Time**.

Relative Humidity (RH) displays the current ambient humidity detected near the Printer.

Printer Messages may appear under **RH (Relative Humidity)**.

Media Icon: Displays the type of media the Printer is currently configured for – **Continuous**, **Diecut** or **Black Mark**. Set the type of media by selecting or tapping the icon and selecting the appropriate media type or using the **Media Scan** function after selecting **Service Menus** from the **View** dropdown.

Printhead Height Icon: Shows current Printhead printing height setting. (*3 dots = Low, Normal, High settings*) Set on **User Interface** screen, **Print Height**.

Printer Icon: Shows status of the **Media Sensors** located in the media feed path of the Printer. Also shows status of Ink Valves, Service Station, Printhead and auxiliary devices (*such as Unwinders and Winders*). These can alert the operator to the type and location of a problem. (*See icon key above.*) Rolling over any of the status icons with your cursor pops up a description of that icon.

System Status displays current status of the Printer and/or an error message.

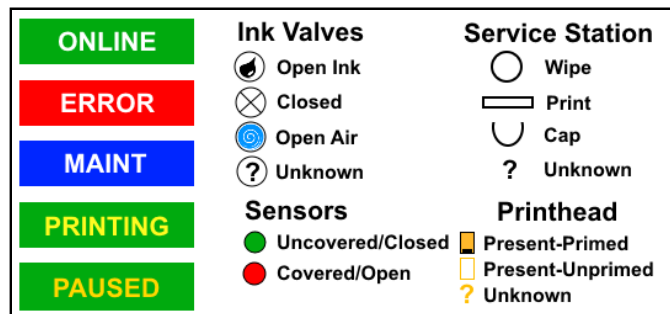
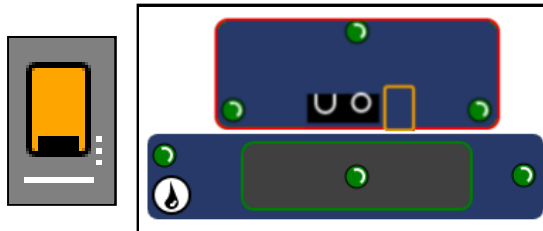
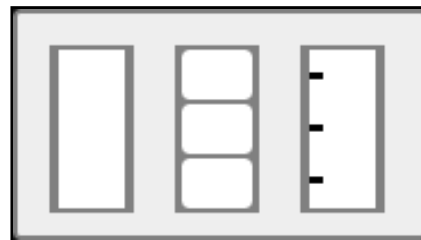
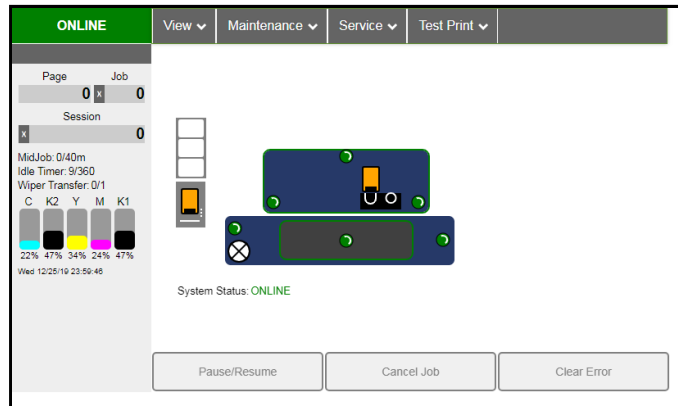

SECTION 3 OPERATING PRINTER

CONTROL BUTTONS (*located along bottom of screen*): Provide quick access to often-used functions.

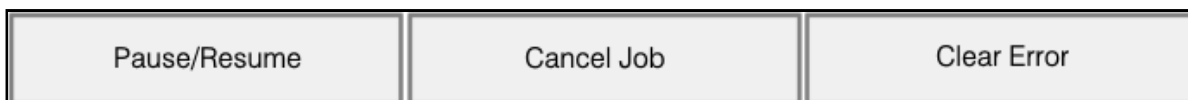

Pause/Resume: Tap to temporarily stop printing. Tap again to resume printing.

Cancel Job: Cancels a paused job from the printing queue. **Cancel** is unavailable unless the **Pause** button has been pressed first. **NOTE: Cancelled jobs must be reloaded before printing can resume.**

Clear Error: Click the button to clear error messages after you have resolved the Printer problem (*i.e., after clearing a paper jam*).

User Interface

SET-UP SETTINGS:

Adjust the Printer for automated service and cleaning intervals, for different types of media and to set the feeder speed for a job.

Mid-Job Servicing – Sets how frequently an automatic maintenance cycle is performed by selecting the length of printed media (*in meters*) that is run between cycles.

Minimum: 60m/197 ft.

Normal (Default): 40m/131 ft.

Maximum: 15m /49.25 ft.

NOTE: “Mid-Job Servicing” can only be set when the Printer is stopped or paused.

Invert Label Gap Sensor –

Used with Blackmark labels and the see-through Media Sensor. Checking the box reverses how the Sensor normally reads the labels and gaps so lighter portions are read as labels, the darker parts are read as gaps. This is useful if the reflective Media Sensor (*normally activated with Blackmark media*) has trouble reading certain types of Blackmark media.

KWS Setting – (*Keep Wet Spitting*) Keeps Printhead hydrated while running a job.

Select from 4 settings: None, Light, Medium (default), and Heavy to determine how much ink will “spit” from Printhead Nozzles. Set in conjunction with “**Mid-Job Servicing**” which determines frequency of Printer stopping for self-servicing during a job.

Interpage Frequency – On roll-to-cut jobs, set when the Printer spits between labels (*to keep the Printhead nozzles hydrated and unclogged*). **For example:** 3 = after every 3rd label; 5 = after every 5th label, etc.

Idle Timeout (min) – Set in minutes how often idle maintenance will run when the Printer is not running.

Wipe Transfer Frequency – Set how often a **Wiper Transfer** (*cleaning excess ink from the Service Station roller*) will be performed in relation to when **Wipe Printhead** or **Printhead Cleaning** is performed. Can be set from 0, (*every time a Wipe Printhead is performed*), or a set number such as 2 (*after every second Wipe Printhead is performed.*)

Media Feed – Sets the Printer Sensors to read the type of media and/or the gaps between media when you select **Continuous, Diecut or Blackmark**.

Internal Print Job Cut – Checking this box allows you to print and cut one of the reports or test pages listed in the **Print** dropdown menu.

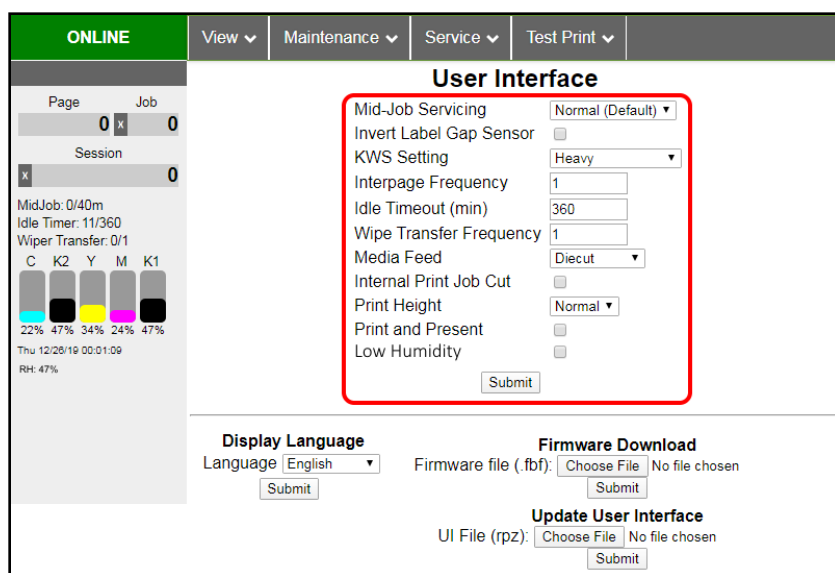
A screenshot of a printer's web-based user interface. The top navigation bar includes 'ONLINE' in a green box, and dropdown menus for 'View', 'Maintenance', 'Service', and 'Test Print'. The main content area is titled 'User Interface' and contains several settings: 'Mid-Job Servicing' (Normal (Default)), 'Invert Label Gap Sensor' (checkbox), 'KWS Setting' (Heavy), 'Interpage Frequency' (1), 'Idle Timeout (min)' (360), 'Wipe Transfer Frequency' (1), 'Media Feed' (Diecut), 'Internal Print Job Cut' (checkbox), 'Print Height' (Normal), 'Print and Present' (checkbox), and 'Low Humidity' (checkbox). A red box highlights the 'User Interface' settings section. Below this are sections for 'Display Language' (English), 'Firmware Download' (Choose File, No file chosen), and 'Update User Interface' (Choose File, No file chosen). A sidebar on the left shows printer status: Page 0, Job 0, Session 0, MidJob: 0/40m, Idle Timer: 11/360, Wiper Transfer: 0/1, and ink levels for C, K2, Y, M, K1.

Print Height – Set the height of the Printhead to adjust for printing on different media thicknesses. Select one of three settings: **High, Normal, and Low**. An indicator appears on the **Status** Toolbox screen and Touchscreen.

Print and Present – Checking the box sets the Printer to print one label at a time and push it out to the cutting position. Useful for certain types of "as needed" printing.

Click **“Submit”** to apply settings.

DISPLAY LANGUAGE: Selects language EWS (*Toolbox*) and Touchscreen will display. Click **“Submit”** after selecting language.

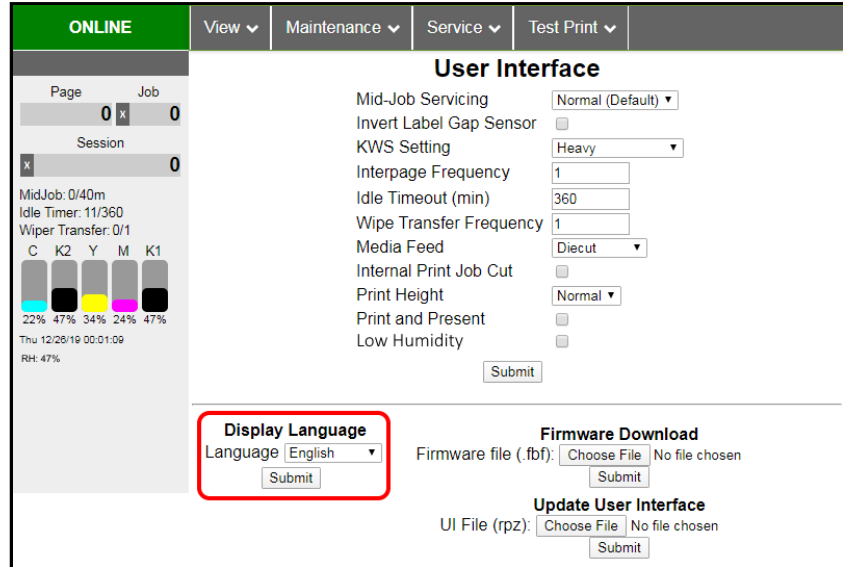

FIRMWARE DOWNLOAD:

You can find and load the latest firmware (“**.fbf**”) files for your Printer using the **Printer Toolbox**.

WARNING: This procedure should only be performed by qualified service personnel. If this process is not performed properly, the Printer is rendered inoperable.

NOTE: Printer firmware can also be applied using a USB Flash Drive and the **Control Panel USB Port**. See **“Using the Control Panel USB Port”**.

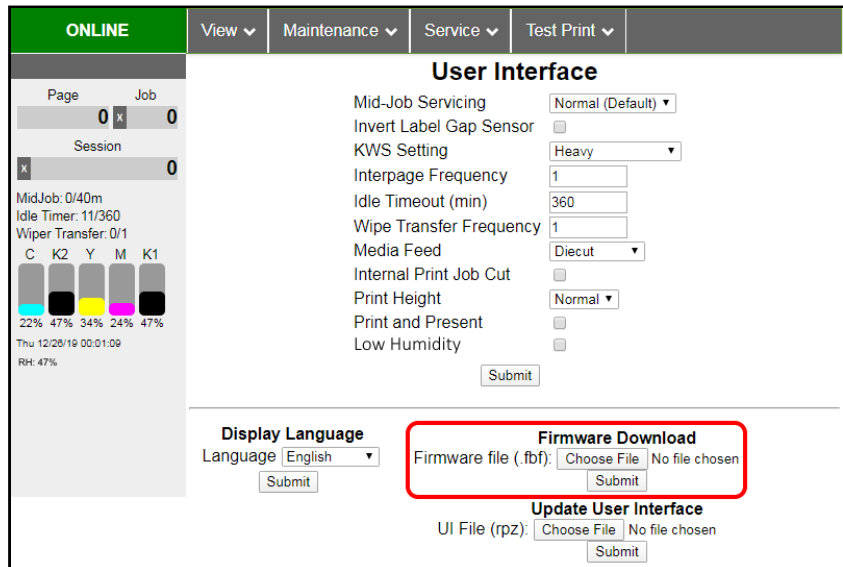

SECTION 3 OPERATING PRINTER

UPDATE USER INTERFACE:

Download and install the latest **User Interface UI** (“**.rpz**”) file for the Printer Touchscreen.

NOTE: Updating this file does not require shutting down or rebooting the Printer.

NOTE: User Interface (UI) firmware can also be applied using a USB Flash Drive and the **Control Panel USB Port**. See “**Using the Control Panel USB Port**”.

ONLINE View Maintenance Service Test Print

Page 0 x Job 0
Session x 0
MidJob: 0/40m
Idle Timer: 11/360
Wiper Transfer: 0/1
C 22% K2 47% Y 34% M 24% K1 47%
Thu 12/28/19 00:01:09
RH: 47%

User Interface

Mid-Job Servicing: Normal (Default) ▾
Invert Label Gap Sensor:
KWS Setting: Heavy ▾
Interpage Frequency: 1
Idle Timeout (min): 360
Wipe Transfer Frequency: 1
Media Feed: Diecut ▾
Internal Print Job Cut:
Print Height: Normal ▾
Print and Present:
Low Humidity:
Submit

Display Language
Language: English ▾
Submit

Firmware Download
Firmware file (.fbf): Choose File No file chosen
Submit

Update User Interface
UI File (.rpz): Choose File No file chosen
Submit

Ink Usage

Displays the amount of ink used and other information about each job sent to the Printer. Also tracks estimated **Page** and **Job Costs** if information is entered in **Job Cost Settings**.

Ink Usage														
Printed Ink (µL)					Time	Job	Pages Printed	Quality	Media Type	Media Size (mm)	Estimated Page Cost	Estimated Job Cost	Estimated Page Cost (1000 Pages)	Estimated Job Cost (1000 Pages)
Cyan	Magenta	Yellow	Black 1	Black 2										
1416	4746	5717	1305	1293	18/05/19 23:37:16	4.3.5x4.25-PMB.pdf	150	Best	Premium Glossy Paper	215 x 279	0.108	16.296	0.107	107.844
12	16	20	9	8	18/05/19 23:34:42	3:5068106_CV_18_edit.pdf	20	Normal	Plain Paper	104 x 241	0.004	0.085	0.002	2.154
19	24	29	23	22	18/05/19 23:28:55	2 SUN PRINTING.pdf	30	Normal	Plain Paper	104 x 241	0.005	0.163	0.004	4.075
11	13	18	47	46	18/05/19 21:56:42	1.Microsoft Word - L901_upgrade.docx	10	Normal	Plain Paper	215 x 279	0.018	0.180	0.016	16.354

Ink Estimation Mode

Mode: Continuous ▾

Page Counter: 2713

Job Cost Settings

Tank Cost:

Printhead Cost:

Media Size: ▾

INK ESTIMATION MODE – Lets you predetermine how much ink a given job may use prior to printing a job. This is useful for determining per piece costs. Job is sent to the Printer and loads, but does not print. Once a job is loaded, click **“Refresh”** to show the amount of ink (by color) that job will use.

Upload Table – Creates and opens a linkable tabular data file using programs such as Microsoft Excel. (*Microsoft Excel is the default.*)

Mode selection:

Off – Feature is disabled.

Continuous – Ink Estimation Mode continues running (*Printer will not print*), until the feature is turned **“OFF”**.

Single Pass – Ink Estimation Mode runs once, then turns off. Printer will then be ready to print.

Click **“Submit”** to activate the **Mode** setting selected.

NOTE: The estimating process takes as long as the job would take to print (*i.e., if a job would take one hour to print, the estimate will take one hour to display. Track progress on the Counter located in the System Status window.*)

Reset Page Counter – Tap or click this button to reset the Printer page count to 0. (**Page** on the Printer Toolbox and Touchscreen.)

JOB COST SETTINGS – Enter your **Ink Tank Cost**, **Printhead Cost** and **Media Size** preference (*inches or mm*). Set a minimum of at least 100 pcs. to ensure a large enough sample size. Click **“Submit”**. In **Ink Estimation Mode**, this feature estimates per page cost and job cost without printing the job (*note that there are columns providing results at both single-page and 1000-page levels*). With **Ink Estimation Mode** disabled, the Printer still tracks the estimated per page cost and estimated job cost as the job is being printed. Once the costs are entered, they will remain until changed again, even if the Printer is turned OFF.

NOTE: This is only an estimate and does not include other factors that may affect the overall result.

Ink Estimation Mode

Mode: Off

Continuous
 Single Pass

ONLINE

Page **1** x

Job **9**

Session

x

98

Mid-Job: 0/40m
Idle-Timer: 217/360
Wiper Transfer: 0/1

Job Cost Settings

Tank Cost:

Printhead Cost:

Media Size: ▾

SECTION 3 OPERATING PRINTER

Service Menus

Clicking **Service Menus** opens the **Service Menu** (*Diagnostics*) screen and service menu buttons.

Diagnostics button. Click to check the status of the Printer.
(See *Diagnostics* below.)

System Settings button. Click to view, enter or change settings to connect the Printer to your network. (See *Network Settings*.) Also configure and set the Printer's **Date and Time**. And set the level of detail desired for **Debug Logs**.

Debug Logs. Click to display a list of available Debug Logs that can be opened or uploaded. Then select the Log or Logs to be uploaded.

Media Scan. Use **Media Scan** to fine tune sensor sensitivity and/or adjust scan length if media is not printing correctly, or to determine if a type of media is going to have problems printing. This is generally due to the sensors having trouble differentiating between the label surface and backing/gap. (See *Media Scan*)

Scan Sensors button. Provides status and a log of sensor activity on the sensors located throughout the Printer. (See *Scan Sensors*.)

Service Menus, Password: Entering the **Service Menu password** provides access to more advanced Printer control and maintenance menus. For authorized service personnel only.

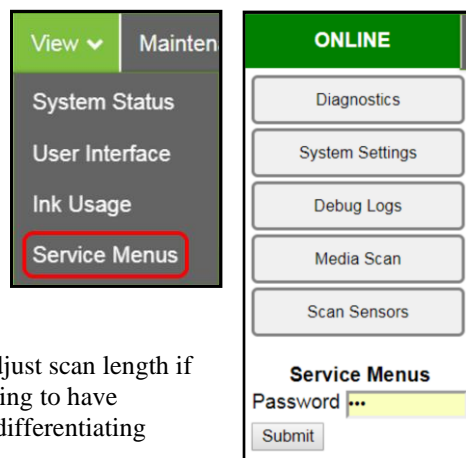

Diagnostics

This is the screen that opens when you select “**Service Menus**”. From this screen you can see current status of the Printer.

Other features:

Upload Debug Log – Upload and save a log of the Printer status to send to a technician to help diagnose a problem. Clicking this button creates a snapshot log showing everything going on with the Printer since powering up. (See *Sample Log at right*.)

NOTE: If a problem arises, try to recreate the problem; then press the **Upload Debug Log** button without performing any other actions.

This may make it easier for the technician to determine the problem. If this is not possible, include any actions you may have taken after the problem began.

Date / Time	Pages	Event	Description
2019-12-19 00:00:09	2922	Firmware upgrade	L1_Mk2_R1.4.1pre05
2019-11-01 23:23:07	2898	Printhead insertion	Unknown
2019-11-01 23:19:43	2898	Printhead insertion	Unknown
2019-10-31 17:13:00	2620	Printhead insertion	B00DP2T

Other information provided in the Diagnostics window:

Event Log History – Displays significant events occurring on the Printer (such as *firmware updates, errors, power off, etc.*) This log is useful for troubleshooting Printer problems.

NVM Settings – Displays the Printer's current NVM, (*Non-Volatile Memory*), settings. (*Once settings are saved, they remain even when Printer is turned off, until they are manually changed.*)

VARS Settings – Displays the Printer's current VARs, (*Variable*), settings. (*Settings that are set for a particular job that automatically revert to the default settings when the Printer is turned off or rebooted.*)



System Settings

Set up a network connection for the Printer. You can also configure and set the Printer **Date and Time**, set the **Debug Log Level** and set the **Screensaver Timeout** (*sleep delay*).

Network Settings – Permits you to view, enter or change settings to connect the Printer to your network.

Network Connection Set -Up:

1. Printer is still connected to the computer via the USB cable. **To connect the Printer to a network:** From the **Toolbox**, select “**View**” drop-down menu, click “**Service Menus**”, then click “**System Settings**”.
2. “**System Settings**” screen opens. Use **Network Settings** to enter the correct settings for your network.

NOTE: If manually changing the **ip_address**, make sure the “**dhcp**” and “**autoip**” boxes are **unchecked**. (*Default is checked.*) Enter changes in the appropriate boxes. Click “**Submit**”.

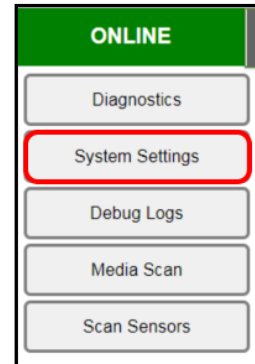
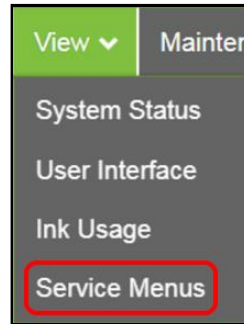

3. Connect the Ethernet cable to the Network Port on the Rear Panel of the Printer.



SECTION 3 OPERATING PRINTER

Date and Time – Enter or change the way the date and time will appear in the **Printer Status** section of the Toolbox screens. **To enter or change Date and Time:**

1. **From the Toolbox**, select “View” drop-down menu, click “Service Menus”, and then click “System Settings”.
2. “System Settings” page opens. Use **Date and Time options** to enter, edit and format the **Date** and **Time** for the Printer.
3. Click “Submit”.

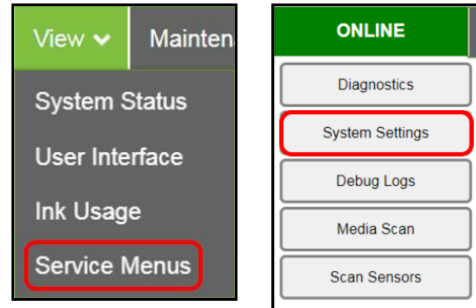

System Settings

Network Settings

Printer Name

Domain Name

dhcp

bootp

autoip

ip_address

subnet_mask

def_gateway

wins_server

private_ip

ui_ip

Date and Time

Date and Time

Format (dd/mm/yy hh:mm)

24 Hour

Date Format

Debug Level

debug_level

Screensaver

ui_timeout_seconds

Debug Level – Set the detail level of the **Debug Logs**. **To change the Debug Level:**

1. **From the Toolbox**, select “View” drop-down menu, click “Service Menus”, and then click “System Settings”.
2. “System Settings” page opens. Go to **Debug Level** options and select 0, 1, or 2 to set the desired detail level for the **Debug Log**. (0 = least detailed, 2 = most detailed). **NOTE:** Because of the amount of data collected and stored, it is recommended that you not set the **Debug Level** over 1 unless asked by a service technician.
3. Click “Submit”.

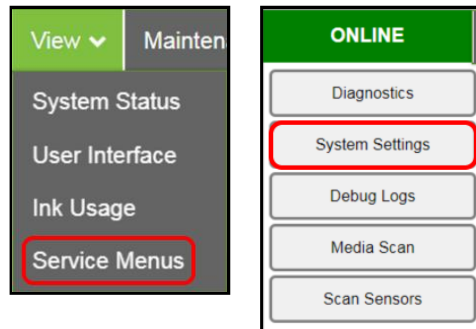

System Settings

Network Settings

Printer Name

Domain Name

dhcp

bootp

autoip

ip_address

subnet_mask

def_gateway

wins_server

private_ip

ui_ip

Date and Time

Date and Time

Format (dd/mm/yy hh:mm)

24 Hour

Date Format

Debug Level

debug_level

Screensaver

ui_timeout_seconds

Screensaver – Set the amount of time the Touchscreen will remain idle before automatically going to **Sleep Mode**.

1. **From the Toolbox**, select **“View”** drop-down menu, click **“Service Menu”**, and then click **“System Settings”**.
2. **“System Settings”** page opens. Go to **Screensaver**. Enter the number of seconds the Touchscreen will remain idle before going to **Sleep Mode**.
3. Click **“Submit”**.

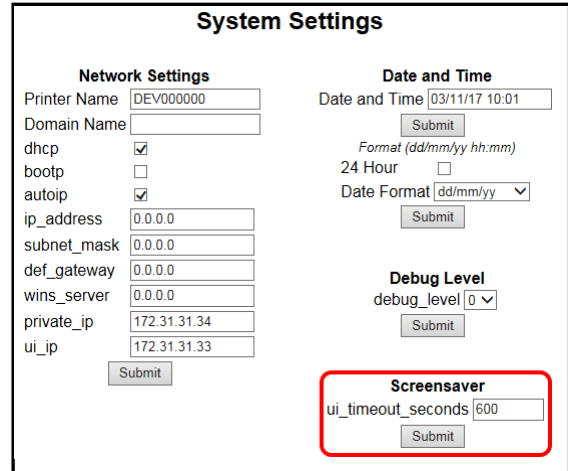
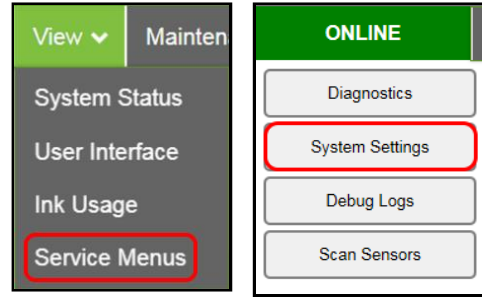

SECTION 3 OPERATING PRINTER

Debug Logs

Access, print or send activity logs for the Printer and for jobs run on the Printer. These files are valuable for diagnosing and servicing problems.

From the **Toolbox**, select the “**View**” drop-down menu, click “**Service Menus**”, and then click “**Debug Logs**”.

All – Shows all log files available.

Debug – Shows only **Debug** log files.

Jobs – Shows only **Jobs** printed log files.

Delete All – Deletes all **Debug** and **Jobs** log files.

Recycle symbol – Deletes the selected file.

ONLINE View Maintenance Service Test Print

Diagnostics **All** Debug Jobs Delete All

System Settings

Debug Logs Media Scan Scan Sensors

Service Menus

Password

Submit

Available Files

Files	Size
debug_2020-01-20.log	3334
debug_2020-01-19.log	7909
debug_2020-01-18.log	7908
debug_2020-01-17.log	7826
debug_2020-01-16.log	13209
debug_2020-01-15.log	5314
debug_2020-01-14.log	5529
debug_2020-01-13.log	7404
job_2020-01-12.log	431
debug_2020-01-12.log	25182
debug_2020-01-11.log	5196
debug_2020-01-10.log	5196
debug_2020-01-09.log	5196
debug_2020-01-08.log	6428
debug_2020-01-07.log	5196
debug_2020-01-06.log	5160
debug_2020-01-05.log	5196
debug_2020-01-04.log	5196
debug_2020-01-03.log	5160

1 2 3 4 5 6

ONLINE View Maintenance Service Test Print

Diagnostics All **Debug** Jobs Delete All

System Settings

Debug Logs Media Scan Scan Sensors

Service Menus

Password

Submit

Available Files

Files	Size
debug_2020-01-20.log	3334
debug_2020-01-19.log	7909
debug_2020-01-18.log	7908
debug_2020-01-17.log	7826
debug_2020-01-16.log	13209
debug_2020-01-15.log	5314
debug_2020-01-14.log	5529
debug_2020-01-13.log	7404
debug_2020-01-12.log	25182
debug_2020-01-11.log	5196
debug_2020-01-10.log	5196
debug_2020-01-09.log	5196
debug_2020-01-08.log	6428
debug_2020-01-07.log	5196
debug_2020-01-06.log	5160
debug_2020-01-05.log	5196
debug_2020-01-04.log	5196
debug_2020-01-03.log	5160
debug_2020-01-02.log	5954

1 2 3 4 5

ONLINE View Maintenance Service Test Print

Diagnostics All Debug **Jobs** Delete All

System Settings

Debug Logs Media Scan Scan Sensors

Service Menus

Password

Submit

Available Files

Files	Size
job_2020-01-12.log	431
job_2019-12-22.log	676
job_2019-12-21.log	101
job_2019-12-20.log	148
job_2019-11-13.log	404
job_2019-11-12.log	605
job_2019-11-06.log	811
job_2019-11-05.log	305
job_2019-11-03.log	265
job_2019-11-02.log	578
job_2019-11-01.log	415
job_2019-10-30.log	574
job_2019-10-27.log	1306
job_2019-10-13.log	319
job_2019-10-10.log	414
job_2019-10-01.log	88
job_2019-09-30.log	361
job_2019-09-27.log	1957
job_2019-09-26.log	4836

1 2

Media Scan

Use **Media Scan** to fine tune sensor sensitivity and/or adjust scan length if the media is not printing correctly, or to determine if a type of media is going to have problems printing. This is generally due to the sensors having trouble differentiating between the label surface and backing/gap.

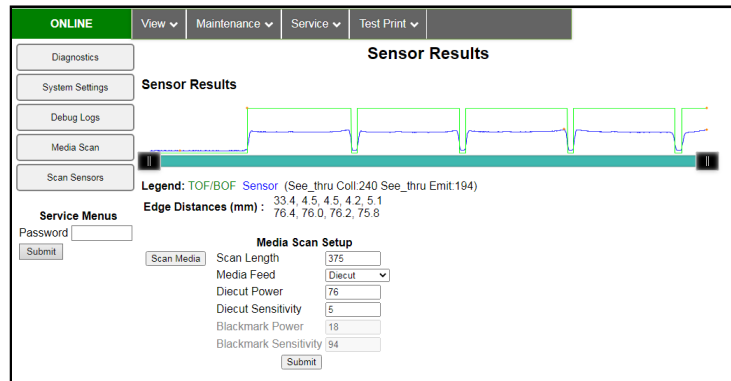

NOTE: If using notched Tags, open the Top Cover and slide the white magnetic strip [A] back to uncover the See-Thru Sensor [B]. Cover the Sensor for all other media.

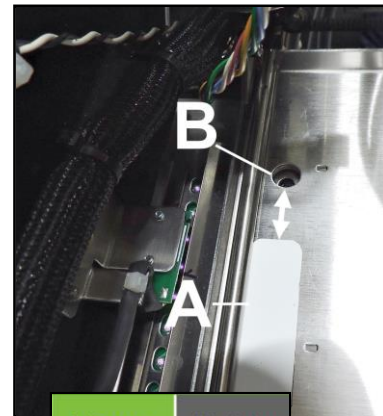

Media Scan Procedure:

1. Load media in the Printer as if printing a job.
2. **From the Toolbox**, select the “View” drop-down menu, click “Service Menus”. Click “Media Scan”.
3. Under “Media Scan Setup”, set “Scan Length”: The media length for the scan in millimeters. Set length at least 4-5 labels long.
4. Set “Media Feed”: Select what type of media is being fed; **Continuous**, **Diecut** or **Blackmark**.
5. For **Diecut** or **Blackmark** media, (some or all of the Sensors may be inactive for different types of media), set Sensor sensitivity:

For Diecut:

Set “Diecut Power”

Set “Diecut Sensitivity”

For Blackmark:

Set “Blackmark Power”

Set “Blackmark Sensitivity”

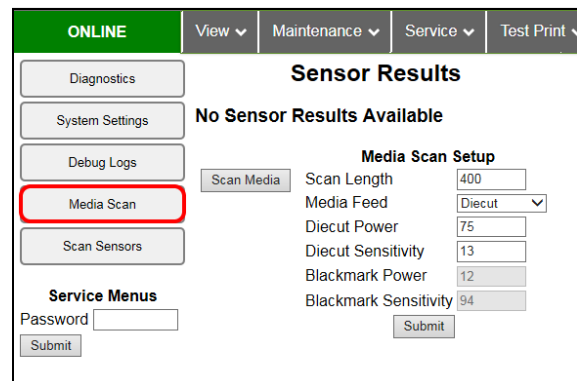
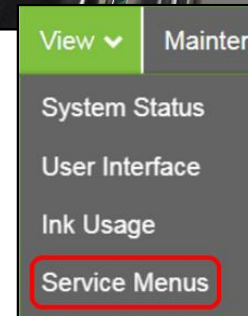

SECTION 3 OPERATING PRINTER

- Click “**Submit**” to enter your selections; then click the “**Scan Media**” button. Blank media moves across sensors to create the graph shown on the screen. **NOTE: Tapping or rolling the cursor over the blue graph line provides readouts of the points on the graph.**

Legend: Explains what the graph is showing.
Media (TOF/BOF-Green line).
Sensor (Sensor-Blue line).

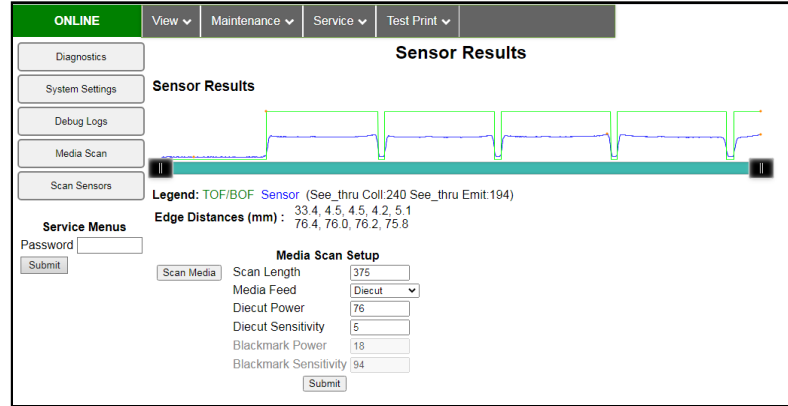

Edge Distances: **Top line** shows the average gap distance reading in millimeters.
Bottom line shows the length of the label reading in millimeters.

- If the graph and/or results require adjusting, you can increase or decrease the Sensor sensitivity by changing the Sensor sensitivity values. You can also increase or decrease the length of media to be scanned by moving the slider on the **Scan Length** bar. Press the **Scan Media** button again to obtain a new result. **NOTE:** Make sure that the label type and the Toolbox Media Feed type icon match. Only the sensors for that type of media will be active. If the label type is different, an **Error** will show in the System Status box. **NOTE: Media Scan** is also available on the Printer Touchscreen. (See *Media Scan in Using the Touchscreen*).

Scan Sensors

Provides status updates and an activity log on the Sensors located throughout the Printer. Provides useful details for Service personnel. (See chart below.) Click “**Stop**” button to stop scanning or click out of “**Scan Sensors**”.

ONLINE					Sensor History																									
View Maintenance Service Test Print					See-Thru Sensor	Reflective Sensor	Exit Sensor	Valve Position	Sled Lift	Lifter Station	Service Home	Lift Encoder	Lift Encoder	Sled Encoder	Sled Encoder	Printhead Latch	Print Encoder	Pump Running	Pump Encoder	Wiper Encoder	Wiper Encoder	Sump Encoder	Valve Sensor 1	Valve Sensor 2	Temperature	Y Out	MOut	COut	K1Out	K2Out
Diagnostics					0	0	0	closed	cap	cap	cap	Off	-4340	Off	-29418	Closed	0	No	-575987	No	-919216	232912	On	Off	255	No	No	No	No	No
System Settings					0	0	0	closed	cap	cap	cap	Off	-4340	Off	-29418	Closed	0	No	-575987	No	-919216	232912	On	Off	255	No	No	No	No	No
Debug Logs					0	0	0	closed	cap	cap	cap	Off	-4340	Off	-29418	Closed	0	No	-575987	No	-919216	232912	On	Off	255	No	No	No	No	No
Media Scan					0	0	0	closed	cap	cap	cap	Off	-4340	Off	-29418	Closed	0	No	-575987	No	-919216	232912	On	Off	255	No	No	No	No	No
Scan Sensors					0	0	0	closed	cap	cap	cap	Off	-4340	Off	-29418	Closed	0	No	-575987	No	-919216	232912	On	Off	255	No	No	No	No	No
Service Menus					0	0	0	closed	cap	cap	cap	Off	-4340	Off	-29418	Closed	0	No	-575987	No	-919216	232912	On	Off	255	No	No	No	No	No
Password					0	0	0	closed	cap	cap	cap	Off	-4340	Off	-29418	Closed	0	No	-575987	No	-919216	232912	On	Off	255	No	No	No	No	No
Submit					0	0	0	closed	cap	cap	cap	Off	-4340	Off	-29418	Closed	0	No	-575987	No	-919216	232912	On	Off	255	No	No	No	No	No

Maintenance Drop-Down

Perform maintenance tasks on the Printer.

Circulate Ink – Purges air from the lines and primes the system after replacing the **Ink Tanks** or **Printhead Cartridge**.

Full Clean Printhead – Runs the cleaning routine multiple times for the most thorough flushing and cleaning of the Printhead.

Normal Clean Printhead – Runs the cleaning and wiping routine twice for a more thorough flushing and cleaning than “**Quick Clean**”.

Quick Clean Printhead – Circulates ink; wipes and cleans the **Printhead Cartridge**.

Inspect Sled – Moves **Service Station** out for inspection, cleaning or service.

End Inspection – Moves **Service Station** back into position under the Printhead.

Wiper Transfer – Squeegees excess ink off of **Service Station Wiper Roller**.

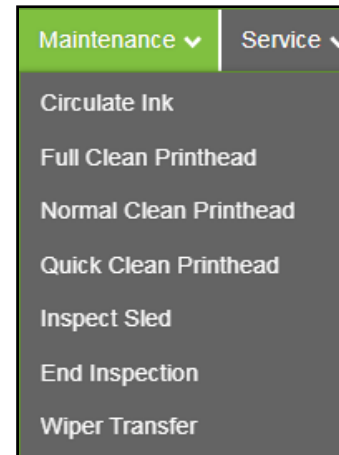

Service Drop-Down

Control functions that require the Printer to be out of service for extended periods of time while they are being performed.

System Deprime – Pumps ink back into the Ink Tanks prior to replacing the Printhead Cartridge or transporting the Printer.

Shutdown – Turns Printer OFF. For best system performance, it is recommended to keep the Print Engine powered-up (*ON/OFF light illuminated*) at all times. If turning the Printer off, first power-down the Print Engine using “**Shutdown**” button in **Toolbox** or ON/OFF button on Control Panel. Wait until the Touchscreen turns off before turning off the **Main Power Switch**.

Restart – Restarts the Printer without having to perform the startup routine (*purging ink tanks, priming, etc.*)

Restart UI – Restarts the **Printer Touchscreen** without having to perform the Printer startup routine (*purging ink tanks, priming, etc.*)

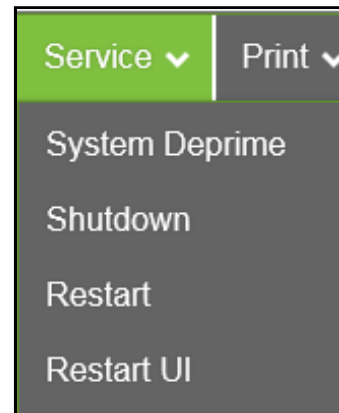

Test Print Drop-Down

Print various reports and Printer tests.

Each printout displays information about the Printer.

Print Setup Page – Prints a printing pattern used for positioning the image on the page.

Print Configuration – Prints the current Printer configuration including Firmware Version, Network Connection, Printer Serial Number and more.

Print Printhead Test – Prints color bands, text and patterns to check condition of the Printhead’s ink nozzles. **NOTE: Uses less ink than “Print Color Bars”.**

Print Color Bars – Prints a series of 7 color bars (*per Printhead*) to indicate how well the Printhead is mixing colors and printing.

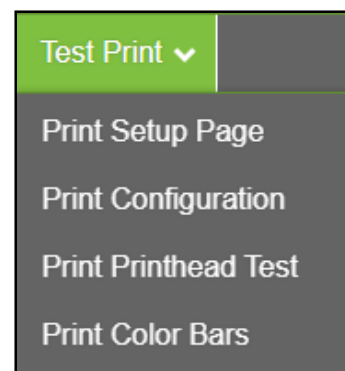

SECTION 4 – Maintenance

General, periodic maintenance is needed to keep the Printer in good working order. This section covers how to care for the Ink Tanks, Printhead Cartridge, Service Station, and clear paper jams.

Replace Ink Tanks

Replace the Ink Tanks when the ink runs out.

1. **Look at the Control Panel Touchscreen.** Ink Tank Status information appears on the right side of the Touchscreen. Note that some or all of the Ink Tank indicators may be low or empty.

CAUTION

VERIFY THAT THE LABELS ON THE INK CARTRIDGE AND THE PRINTER'S INK STATION MATCH. BOTH SHOULD BE "DN" OR BOTH SHOULD BE "DG".

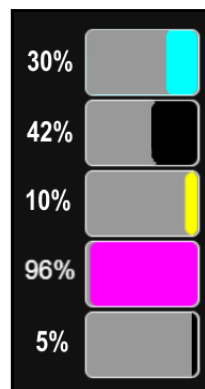

2. **Open the Ink Tank Door** (*hinged at bottom*). (*Disconnects Printer communication with Ink Tanks and allows safe installation and replacement.*) Open the Ink Tank Latches [A] and pull Ink Tanks [B] out of Printer.

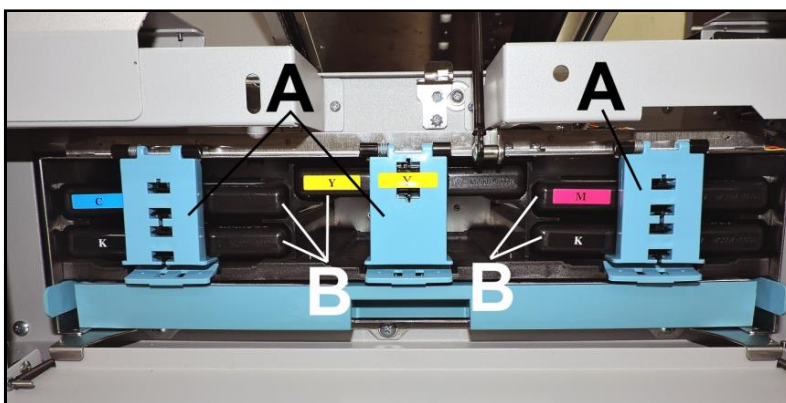

3. Remove the new Ink Tanks from packaging.
4. Slide the new Ink Tanks (*labels up*) into the appropriate color slots [B]. Close the Ink Tank Latches.

INSTALLATION TIP:

Make sure the Ink Tanks seat properly. Insert the Ink Tank into the appropriate Ink Station, then pull the Ink Tank back about an inch and push it forward firmly to insure that the Ink Nozzles penetrate the seals on the Ink Tanks.

5. **Close the Ink Tank Door.** Ink colors fill in as the Ink Tanks are installed. If the ink colors do not fill in after a few seconds, open the Ink Tank Door and reinstall the Ink Tanks.

NOTE: If the Ink Tank is installed, but the Ink Tank indicator still does not refresh, see “Clean Ink Tank Contacts” below.

6. When the Printer stops processing and no errors appear on the System Status screen, the Printer is ready for use.

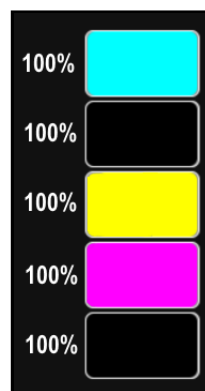

WARNING!

Ink in Ink Tanks may be harmful if swallowed. Keep new and used Ink Tanks out of reach of children. Discard empty Ink Tanks immediately.

SECTION 4 MAINTENANCE

Clean Ink Tank Contacts

When reinstalling or replacing the Ink Tanks; the Ink Level indicators on the Touchscreen may not refresh. This may be due to a dirty Ink Tank Level Prism and/or QA Chip contacts on that Ink Tanks.

Clean contacts as follows:

1. **Remove the Ink Tanks.** Open the Ink Tank Door. Release the Ink Tank Latches [A]. Remove the Ink Tanks [B] that did not refresh.

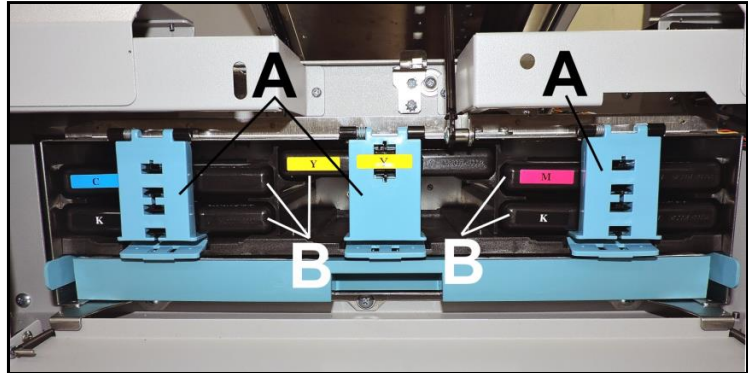

2. Clean the Ink Level Prism [A] and QA Chip contacts [B] with a clean, dry, lint-free cloth. **NOTE: Dampen the cloth with distilled water to wipe the Prism, but DO NOT get the QA Chip contacts wet.**
3. Reinstall the Ink Tanks (*labels up*); close the Ink Tank Latches. Close the Ink Tank Door.

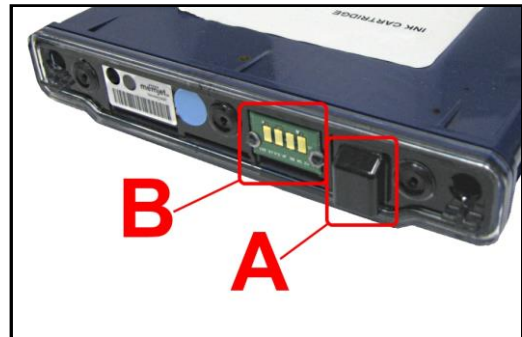

Storage

New Ink Tanks should be stored in the original packaging and kept away from heat.

Opened Ink Tanks should remain in the Printer.

Nominal Ink expiration date: 24 months following date of manufacture (*ink fill date*).

Disposal

Safely dispose of the Ink and Ink Tanks in accordance with local/national regulations.

Clean up spills with soap and water. Abrasive soap is effective in cleaning ink off your hands.

Clean/Replace Printhead Cartridge

Cleaning

The Printhead is cleaned automatically each time the Printer is turned on or when the “Quick Clean Printhead” routine is performed. This can be found under “Service” Tab, “Normal Clean Printhead” in the Printer Driver or “Maintenance” drop-down menu on Touchscreen. If running automated Cleaning Levels doesn’t help improve print quality, the Printhead Cartridge can be cleaned manually.

1. From the Touchscreen, tap “Setup” in the Menu drop-down; then tap “System Deprime”. The Printer pumps any ink in the system back into the Ink Tanks. Then the Printhead Latch pops open.

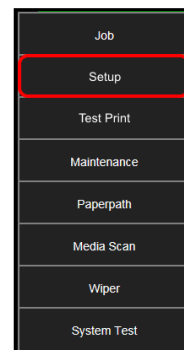

CAUTION

DO NOT PRY OR MANUALLY LIFT PRINTHEAD LATCH OR LATCH MAY BREAK. ONLY OPEN LATCH USING THE RELEASE PRINTHEAD BUTTON ON THE TOUCHSCREEN OR IN THE PRINTER TOOLBOX.

2. **Open Top Cover.** Make sure the Printhead Latch is fully opened to retract the ink lines. Remove the used Printhead Cartridge by tilting it toward the ink lines, then carefully lifting it out of the Printhead Compartment.
3. Moisten the Printhead nozzles using deionized/distilled water (*reference ASTM D5127-90 Type E-II Electronic Grade Water*) and a damp, lint-free cloth, wiping end to end. (*Gray strip located below orange strip.*) **Take care not to damage the copper contacts, metal plate, or Printhead surface.**
4. Reinstall Printhead, close Printhead Latch and close Top Cover.

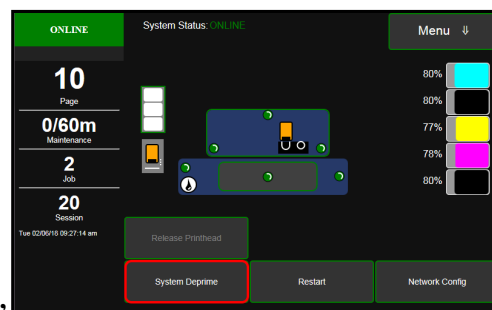

Generally, when the ink supply is adequate and the print quality remains poor, or when automated cleaning processes or manually cleaning the Printhead does not help the image quality, replace the Printhead.

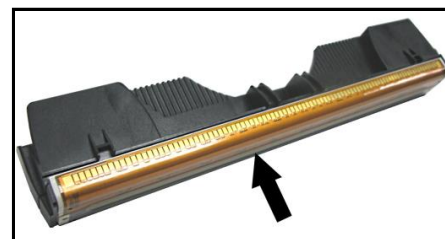

CAUTION

- Use electrostatic discharge (ESD) protection when handling.
- Hold Printhead Cartridge by handles ONLY.
- DO NOT touch ink couplings, nozzle surface or electrical contacts.

SECTION 4 MAINTENANCE

- **DO NOT** unpack the Printhead Cartridge until the Printer is ready for installation. Once unwrapped, delay in installing the Printhead can compromise print quality due to dehydration.
- **DO NOT** place an unwrapped Printhead on any surface before installing. Protect Printhead from scratches, dust, fibers, dirt and other contaminants at all times.

Replace Printhead Cartridge

IMPORTANT

TO ENSURE OPTIMUM PRINTING PERFORMANCE, INSPECT AND REPLACE THE WIPER ROLLER AS NECESSARY WHEN REPLACING THE PRINthead.

- From the Touchscreen, tap “Setup” in the Menu drop-down; then tap “System Deprime”. The Printer pumps any ink in the system back into the Ink Tanks. Then the Printhead Latch pops open.

CAUTION

DO NOT PRY OR MANUALLY LIFT PRINthead LATCH OR LATCH MAY BREAK. ONLY OPEN LATCH USING THE RELEASE PRINthead COMMAND ON THE TOUCHSCREEN OR IN THE COMPUTER TOOLBOX.

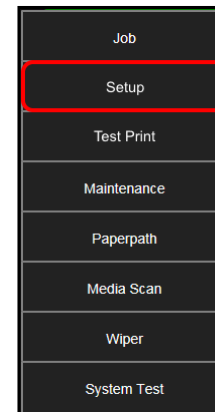

- Open Top Cover.** Make sure the Printhead Latch is fully opened to retract the ink lines. Remove the used Printhead Cartridge by tilting it toward the ink lines, then carefully lifting it out of the Printhead Compartment.

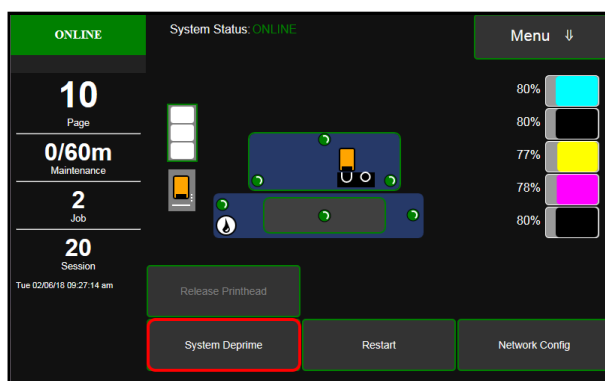

- [A] Carefully remove the Printhead Cartridge from foil packaging. Tear foil at notch or cut the end with scissors.



- [B] Remove protective plastic cover. Hold Printhead by handle and unclip cover from Printhead.

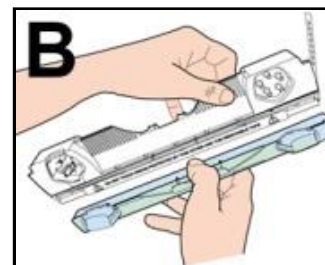

- [C] Remove protective strip from Printhead electrical contacts. Once removed, DO NOT allow strip to touch electrical contacts.

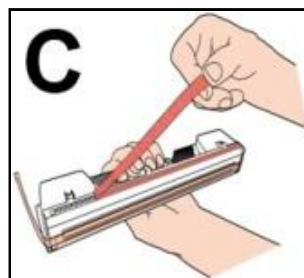

- [D] Remove protective strip from Printhead Nozzles. Hold Printhead by handle. Pull strip tab and slowly peel strip from Printhead. DO NOT pull strip at less than a 45° angle from Printhead surface. DO NOT allow removed strip to touch Printhead Nozzles.

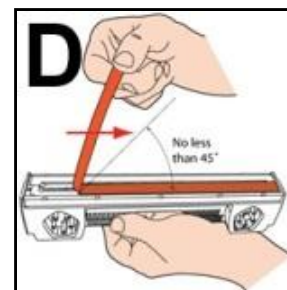

NOTE: Keep foil packaging to store/dispose of old Printhead Cartridge.

SECTION 4 MAINTENANCE

4. **Wet Printhead Surface.** (*Ensures that Printhead will prime correctly.*) Moisten the Printhead nozzles using distilled water and a damp, lint-free cloth, wiping end to end. (*Gray strip located below copper contact strip.*) **Take care not to damage the copper contacts, metal plate, or gold Printhead surface.**

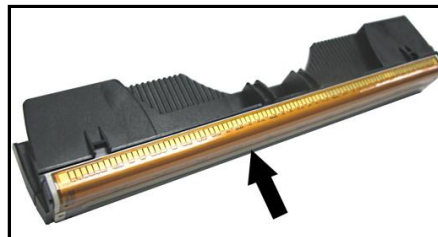

5. Carefully insert the Cartridge into compartment at an angle [4], with Printhead surface facing down and Ink Nozzles facing Ink Hoses. Once seated, gently tilt Cartridge back until it snaps into an upright position [5]. **DO NOT FORCE the Printhead Cartridge into position.**

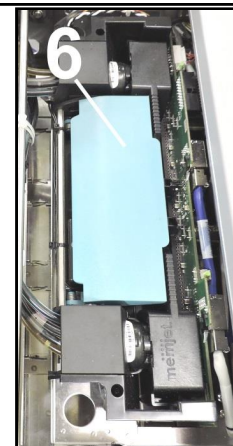
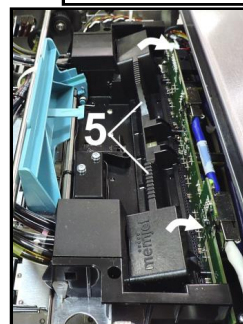
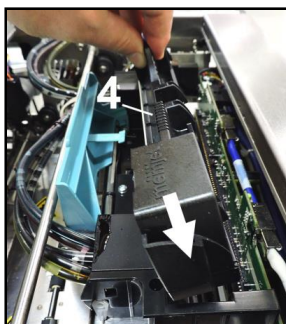

7. **Close Printhead Latch [6].** Close the Top Cover. Printer starts up and primes ink into Printhead. (*This may take a few minutes.*) **NOTE:** When priming stops, open the Top Cover and check that ink is flowing through hoses. If air bubbles appear, tap lines and close the Top Cover. Or close the Top Cover and click **“Circulate Ink”** on Touchscreen to clear the air bubbles.

8. **Watch the Control Panel Touchscreen.** Check that the Printhead icon [7] in the Printer image is primed (*solid color*).
9. When **ONLINE [8]** appears, the Printer is ready for use. **NOTE:** If the Printhead icon continues to display an outline or a question mark (?) try the following procedures:



[1] **Printhead icon shows an outline** (*Printhead unprimed*): Click **“Circulate Ink”** under **“Maintenance”** drop-down in Printer Toolbox. If the issue persists, try the **“Install Printhead”** procedure again. If this does not clear up the issue, call for technical support.

[2] **Printhead icon displays a question mark** (*Printhead not recognized*): Try the **“Install Printhead”** procedure again. If the issue continues, call for technical support.

NOTE: Printer may take up to 12 minutes to set itself up during initial startup. This is normal.

IMPORTANT!

CHECK INK TANKS. PRINTER MAY NOT FULLY REPRIME IF THE INK TANKS ARE LESS THAN 1/3 FULL.

Printhead Storage

Store and transport the cartridge as indicated by the “**this side up**” arrow symbol on the packaging.

The cartridge and ink supply must be within the operating temperature range before attempting to prime the cartridge with ink and starting to print. When stored at temperatures below the operating range, it may take up to 3 hours for a cartridge in its packaging to reach operating temperature.

NOTE: Additional packaging will increase the time needed to reach operating temperature.

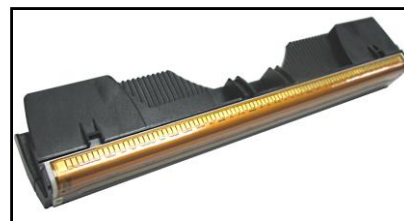

Storage Life: 12 months from date of manufacture (*printed on shipping box*).

Storage Temperature Range:	Long Term: 14° F to 86° F (-10° C to 30° C) Short Term: -11° F to 140° F (-25° C to 60° C) NOTE: Cumulative storage duration above 86° F (30° C) must not exceed 72 hours.
Humidity Range:	5% to 95% Relative Humidity, non-condensing
Atmospheric Pressure Range:	70 kPa to 106 kPa
Electrostatic Discharge:	8 kV air discharges or 4 kV contact discharges* *When tested in accordance with IEC 61000-4-2

Printhead Service Life

Projected: 50,000,000 ejections per nozzle. Printhead has a total of 70,400 nozzles (*14,080 per color channel*.) Since printing does not use the entire length of the Printhead, some nozzles do not fire as often. The most often used Nozzles will degrade more quickly. Noticing the effects of the failing nozzles depends partly on the relative position of those nozzles to each other. In simple terms, the number of images printed and the amount of ink that will pass through the printhead prior to printhead degradation will depend on the make-up of the images printed, operating environment, servicing, media characteristics (*including cleanliness*) and other factors.

SECTION 4 MAINTENANCE

Inspect the Service Station

The Service Station (*located directly under the Printhead Assembly*) cleans the Printhead Cartridge of excess ink and debris, keeps the Printhead hydrated and protected when not in use, captures and removes ink used to keep the nozzles clear. It moves out of the way of the Printhead during printing. It is designed to provide a long service life.

To access the Service Station for inspection and cleaning:

1. Using the **Touchscreen**, select “**Menu**”; then tap “**Maintenance**”; then tap “**Inspect Sled**”. The Service Station [A] moves out from under the Printhead Assembly.
2. Open the Top Cover.
3. Visually inspect the Service Station for cleaning or service. Use a dry, lint-free cloth to soak up any excess ink from the Cap Station [B].
4. Tap “**End Inspection**” on the Touchscreen to move the Service Station back under the Printhead Assembly.
5. Close the Top Cover.

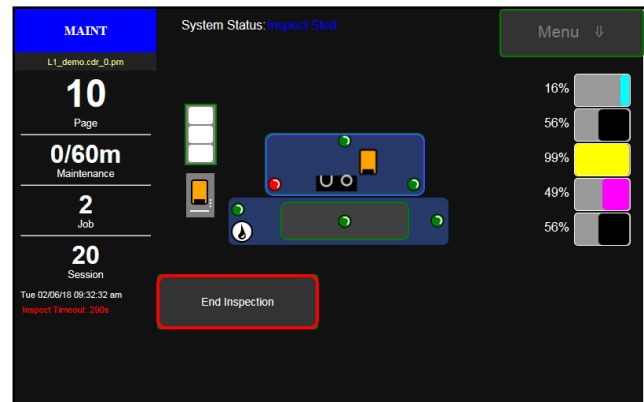
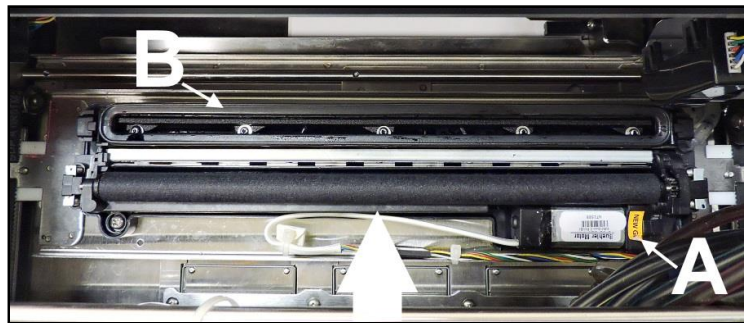
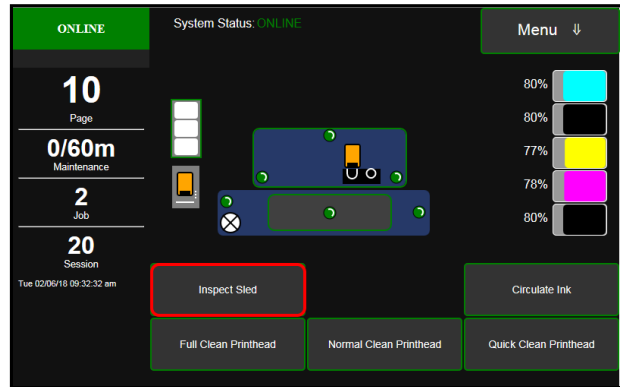

Replace Ink Waste Tray

Ink Waste Tray soaks up any excess ink that may drip from the Print Engine during operation. After a period of time it may become saturated and need replacement.

1. Open the Ink Tank Door.
2. Push in on the Tabs [A] to release the Ink Waste Tray and remove it from unit.
3. Replace with the new Ink Waste Tray [B].

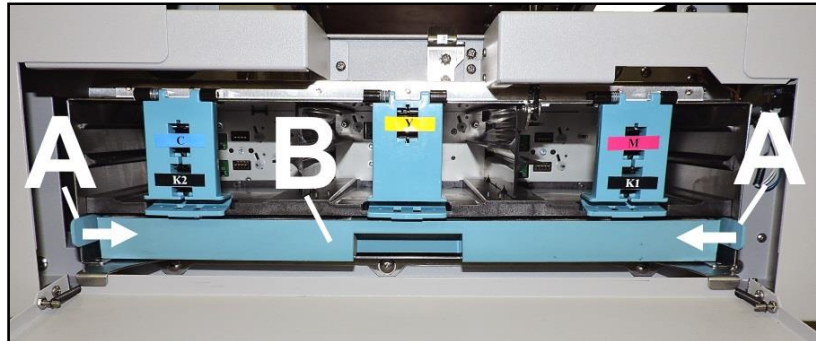

Jams in Printer

Clearing a jam depends on where the jam occurred.

Print Area:

- Open the Ink Tank Door.
- Pull the Clamshell Latch [A] toward you to unlatch the Clamshell.
- Raise Clamshell [B].
- Clear the jam, then carefully lower the Clamshell.

CAUTION
DO NOT ALLOW THE CLAMSHELL TO DROP OR SLAM CLOSED.

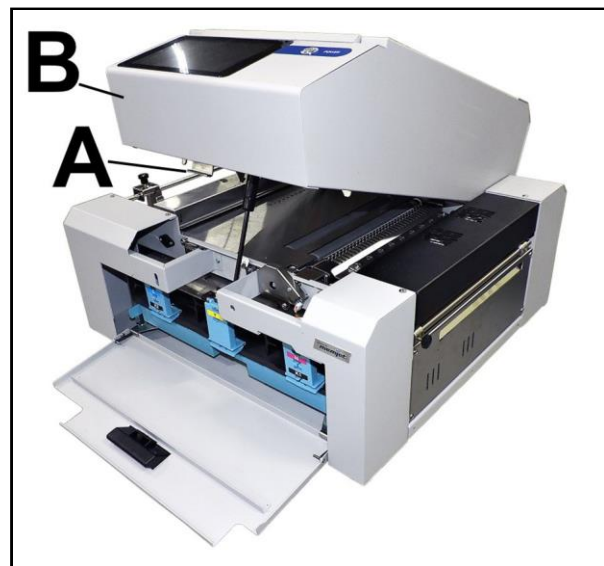

Misfeeds

To correct misfeeds:

Roll Feed – Unwinder/Rewinder may be moving too fast or slow for job being printed.

Readjust Speed Controls on Unwinder and Rewinder.

Fanfold – Straighten stack.

Cleaning

WARNING!

PRINTER IS A PRECISION MACHINE. CLEAN REGULARLY TO INSURE MANY YEARS OF SERVICE. BEFORE PERFORMING ANY MAINTENANCE, DISCONNECT MACHINE FROM ITS POWER SOURCE!

DO NOT REMOVE SIDE COVERS! HIGH VOLTAGES PRESENT.

Clean the Printer regularly to remove accumulated paper dust and ink. Depending on the types of media run, paper dust may accumulate inside the Printer and on the Transport.

1. Turn the Printer OFF and unplug it from the power receptacle. Then open or remove the Covers.
2. **Interior:** Use a vacuum with a soft brush attachment or a can of compressed air to help loosen dust particles. **NOTE: Be careful around the ink tray and capping station** in the Print Engine area as accumulated ink may splash onto other parts of the Printer. Take care not to damage the PC Boards or electrical wiring.
3. **Exterior:** Wipe clean with a lint-free cloth using any standard nonabrasive household cleaner that does not contain plastic-harming solvents.

CAUTION

NEVER SPRAY OR POUR CLEANERS DIRECTLY ON OR INTO PRINTER. EXCESS LIQUID COULD HARM ELECTRONIC PARTS. DAMPEN A LINT-FREE CLOTH WITH THE CLEANER AND APPLY IT TO PARTS TO BE CLEANED.

Feed Rollers and Forwarding Rollers

Feed, Forwarding and Transport Rollers can become glazed with paper lint and ink from the media. Clean regularly with a mild abrasive household cleaner on a damp lint-free cloth.

NOTE: Avoid using solvents on Rubber Rollers.

Print Engine

Areas in the Print Engine can become glazed with a buildup of dust, paper lint and accumulated ink and have to be cleaned regularly. Open the Top Cover. Open the Clamshell Assembly by releasing two latches. Use a vacuum to pick up any loose debris.

NOTE: Be careful around the Ink Tray and Capping Station in the Print Engine area as accumulated ink may splash onto other parts of the Printer. Take care not to damage the PC Boards or electrical wiring.

CAUTION

USE ONLY DEIONIZED/DISTILLED WATER TO CLEAN THE PRINT ENGINE COMPONENTS. AVOID CONTAMINATING THE PRINTHEAD WITH CLEANERS, LUBRICANTS OR OTHER CHEMICALS.

[A] Media Sensors: Paper lint and dust may build up on the Media Sensors. Use a can of compressed air or a damp (*not wet*) foam or lint-free cotton swab to gently swab the Sensors. Take care not to drip water into the Circuit Boards. Use a clean, dry swab to dab surfaces dry.

[B] Rubber Rollers. Clean as needed using distilled water with a damp, lint-free cloth. Be careful not to splash or drip ink on other parts of the Printer.

[C] Printing Surfaces, Ink Drip Cover and Tray. Wipe using distilled water and a damp, lint-free cloth. Pat dry with a lint-free cloth.

Ink Drip Tray: Carefully remove the Ink Drip Tray Cover and Ink Drip Tray. **DO NOT tip the Tray or ink may spill.** Wipe off excess ink; then clean using distilled water and a damp, lint-free cloth.

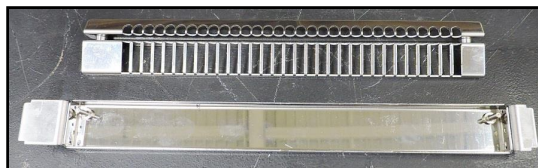
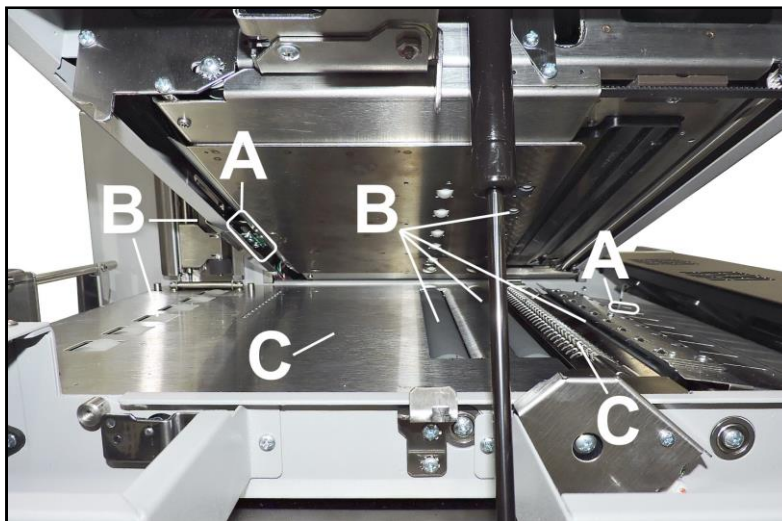

Clean Ink Revolver Couplings

1. First, deprime the system and remove the Printhead Cartridge.
2. Moisten a foam swab in distilled water.
3. Insert the swab into one of the ink channels and rotate the swab to clean the chamber.
4. Use a new swab for each of the remaining ink channels until all 10 openings are clean. (*5 on each side.*)

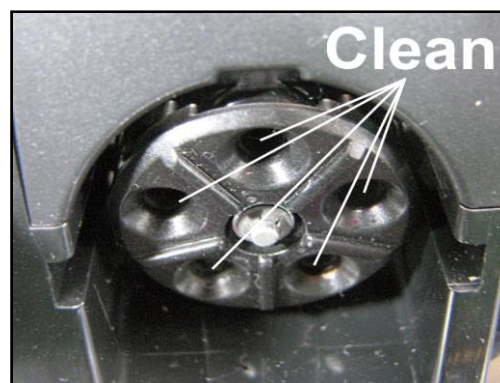

SECTION 4 MAINTENANCE

Shipping or Transporting Printer

If you have to ship or transport the Printer for any reason, the unit will have to be prepared. Once the Printer is prepared, carefully package the Printer, Printhead Cartridge, Service Station and Ink Tanks in the original packaging.

Remove Printhead Cartridge

1. From the Touchscreen, tap “**Setup**” in the **Menu** drop-down; then tap “**System Deprime**”. The Printer pumps any ink in the system back into the Ink Tanks. Then the Printhead Latch pops open.

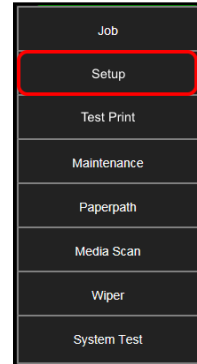

CAUTION

DO NOT PRY OR MANUALLY LIFT THE PRINthead LATCH OR LATCH MAY BREAK. ONLY OPEN THE LATCH USING THE RELEASE PRINthead BUTTON ON THE TOUCH-SCREEN OR IN THE PRINTER TOOLBOX.

2. **Open the Top Cover.** Make sure the Printhead Latch is fully opened to retract the ink lines. Remove the used Printhead Cartridge by tilting it toward the ink lines, then carefully lifting it out of the Printhead Compartment.
3. Pack the Printhead Cartridge area with absorbent towels to catch any ink drips or spills. Carefully pack the Cartridge using the original packaging.

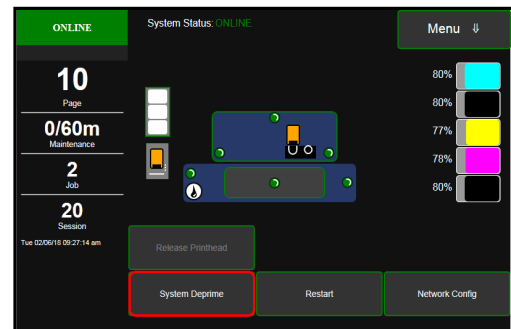

Empty and Clean Ink Drip Tray

1. **Open the Clamshell.**
2. Carefully lift the two tabs out of the slots in the Print Engine Frame and remove the Ink Drip Tray Assembly [A]. **DO NOT tip the Tray or ink may spill.** Empty the Tray if necessary and wipe off excess ink. Clean using distilled water and a damp, lint-free cloth.
3. Reinstall the Ink Drip Tray Assembly.

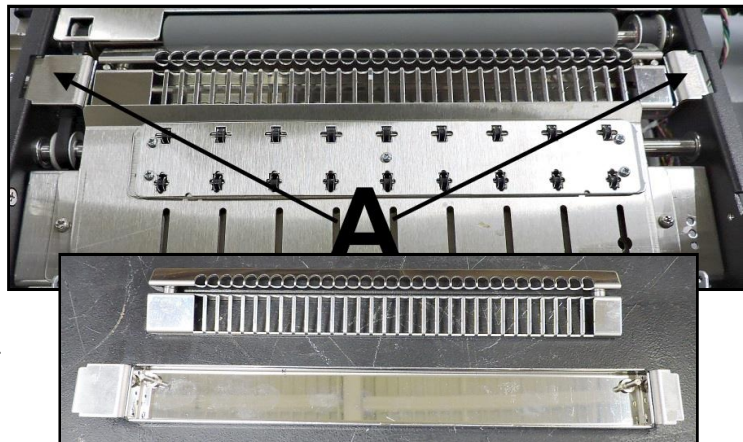

TURN PRINTER POWER OFF.

CAUTION

WHENEVER POWERING DOWN THE UNIT, ALWAYS:

1. PRESS THE POWER BUTTON ON THE CONTROL PANEL.
2. WAIT FOR THE PRINTER TO STOP PROCESSING.
3. THEN PRESS THE MAIN POWER SWITCH ON THE REAR PANEL.

Remove Ink Tanks

1. After depriming the system, open the Front Cover (*hinged at bottom*). Open the Ink Tank Latches [A] and pull the Ink Tanks [B] out of the Printer.
2. Carefully package the Ink Tanks in the original packaging.
IMPORTANT: Make sure the ink seals on the Ink Tanks face up to prevent leakage.

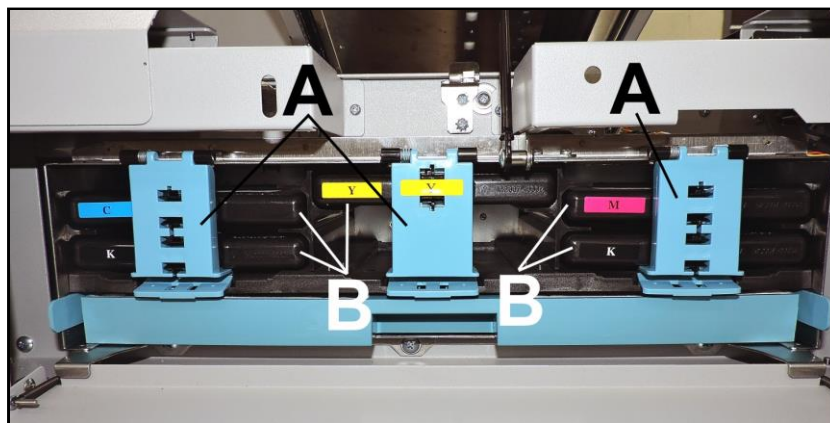

3. Pack the Ink Tank bays with absorbent towels to catch any ink drips or spills.

SECTION 5 – *Troubleshooting Guide*

Troubleshooting Guides are provided to assist in solving any problems that might occur with the Printer. We tried to make them as complete as possible. The best advice we can offer is to make sure that the system is set up properly, plugged in, and has an adequate supply of ink before attempting to troubleshoot any problem.

Memjet® Printhead

CONDITION	PROBLEM	SOLUTION
Missing parts of letters or text.	Air and bubbles blocking Nozzles.	Clean Printhead using recirculation, priming or cycles of depriming and priming found on the Printer Touchscreen or in the Printer Toolbox . Rehydrate Printhead using distilled water and a wet, clean, lint-free cloth. Air bubbles often disappear with Printer use.
Print shows regularly missing or misdirected nozzles or ink color mixing.	Debris on Printhead.	Perform startup routine. Clean Printhead using a Cleaning Level on the Printer Touchscreen or in the Printer Toolbox . Wipe Printhead manually with distilled water and a wet, clean, lint-free cloth. Replace Printhead.
Ink mixing – Mixed or muddy colors.	Causes: Ink flooding, air in Printhead or a dirty Printhead.	Clean Printhead using a Cleaning Level on the Printer Touchscreen or in the Printer Toolbox . Wipe Printhead manually with distilled water and a wet, clean, lint-free cloth.
No print or crisp blocks of missing drops.	Electrical failure or poor electrical connection.	Reseat Printhead. Replace Printhead.
System will not reprime ink after replacing Printhead Cartridge	Printhead nozzles dry. Ink Tanks may be 1/3 full or less.	Wipe Printhead manually with distilled water and a wet, clean, lint-free cloth. Replace Ink Tanks.

WARNING!

**DO NOT REMOVE SIDE COVERS OF PRINTER!
HIGH VOLTAGES PRESENT BEHIND COVERS!**

Printer

CONDITION	PROBLEM	SOLUTION
Ink Tank installed, no Ink Level indication in Toolbox	Ink Tank contacts dirty, preventing Printer/Ink Tank communication.	Remove Ink Tank(s). Clean prism and QA Chip contacts; see Maintenance, Cleaning Ink Tank Contacts.
Extra lines; losing data	Database problem.	Check data in database program.
Improper output (address information out of order, misfeeding, etc.)	Wrong interface settings. Static electricity. Dirty Media Sensor.	Check software or database on PC. Close software; then turn Printer OFF and ON. Clean Media Sensor.
Media jams	Misfeeds. Media is curled or bent. Media is too thin.	Label Rolls: Adjust Unwinder/Winder speed. Fanfold Labels: Check if labels are stuck together. Uncurl media. Minimum thickness for media is 0.004".
No communication	Improper cabling / connector. Unit not receiving power.	Use a proper USB cable. Check plug connections, ON/OFF button and fuse on back panel.
Print too light or missing character dots	Clogged or dirty Printhead. Running out of ink.	Check Printhead. Check Ink Tanks.
Blurry address 	Image is not sharp.	Clean Printhead using a Cleaning Level on the Printer Touchscreen or in the Printer Toolbox . Clean Printhead manually using distilled water and a wet, clean, lint-free cloth.
Feeding problems	Misfeeds.	Label Rolls: Adjust Unwinder/Winder speed. Fanfold Labels: Check if labels are stuck together. Check if labels are sticking together.
Job is sent to print but does not print.	Printer not turned ON. Printer not connected to computer. Media Sensor is covered in Print Engine.	Check that Printer is ON. Connect printer cable to computer and resend job. Open Print Engine and remove media.

**SECTION 5
TROUBLESHOOTING**

Errors and Warnings

Printer Alert Window Messages

Messages sent from the Driver are displayed on the PC screen in a small popup window.

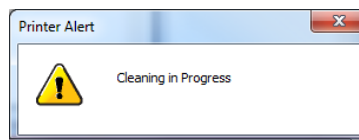

MESSAGE	SOLUTION
Cleaning in Progress	Wait until message disappears. Printer will start printing your job once cleaning process is complete.
Excessive Tilt Error	See details under “ Toolbox System Status Messages ” section.
Incompatible Printhead	Remove and reinsert your Printhead Cartridge. Replace Printhead. Printhead Cartridges must be purchased from authorized supplier for this printer model.
Incorrect ... Ink Tank	Replace Ink Tank. Ink Tanks must be purchased from authorized supplier for this printer model.
... Ink Low Example: Black Ink Low	Reorder Ink.
... Out of Ink Example: Cyan Ink Out	Replace empty Ink Tank.
Load Paper	Out of Paper. Load media into Printer and press PAUSE/RESUME button to resume printing.
Mechanical Jam	Check for and remove obstruction, then press PAUSE/RESUME button to resume printing. Check/Clean Sensors. If problem persists, contact technical support.
Missing Printhead	Remove Printhead Cartridge. Check/clean electrical contacts. Reinsert Printhead. Replace Printhead. If problem persists, contact technical support.
Multiple Inks Low	Reorder Ink.
Multiple Ink Tanks Out	Replace empty Ink Tanks.
Multiple Ink Tanks are missing	Insert missing Ink Tanks. Clean electrical contacts and reseal Ink Tanks.
Multiple Unauthorized Ink Tanks	Remove and reinsert Ink Tank. Replace Ink Tank. Ink Tanks must be purchased from authorized supplier for this printer model.
Paper Jam	Remove jammed media. Check for proper feed setup then press PAUSE/RESUME button to resume printing. Check/Clean Sensors. If problem persists, contact technical support.
Printhead Latch Open	Ensure that Printhead Cartridge is inserted properly, then close Printhead Latch so that it locks.
Print Zone Assembly (Clamshell) Open	Check to be sure Clamshell is completely closed and latched.
The ... Ink Tank is missing	Insert missing Ink Tank. Clean electrical contacts and reseal Ink Tank.
Unauthorized ... Ink Tank Installed	Replace Ink Tank. Ink Tanks must be purchased from authorized supplier for this printer model.
Unauthorized Printhead	Replace Printhead Cartridge. Printhead Cartridges must be purchased from authorized supplier for this printer model.

Toolbox System Status Messages

Use the **Touchscreen** or **Toolbox** screen to quickly determine and locate a problem in the Printer. **Status Indicator** shows **ERROR** in a red box. **Printer Graphic Icon** highlights the Printer and system affected. The **System Status** information displays the basic problem (*in red*). **Ink Levels** displays ink status. **Control Buttons** (*at screen bottom*) let you perform often used tasks without leaving the screen.

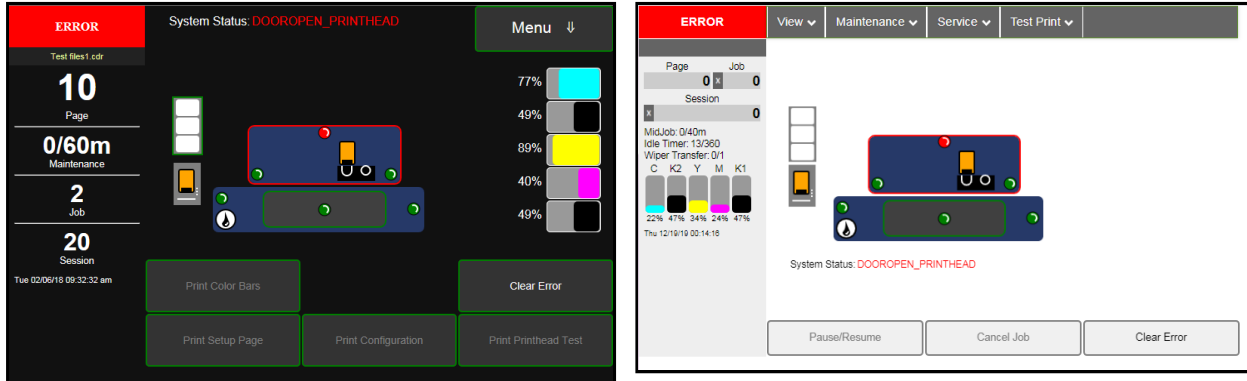

Listed below are some of the messages that may appear in **System Status**.

SYSTEM STATUS	SOURCE	SOLUTION
System Status: PAPERPATH_END_OF_ROLL	Out of media. Unwinder Label Tension Arm has hit its upper or lower limit. End of media did not release from roll core. Tape too strong	Load new roll of media into the Printer. Tap Clear Error button and then tap the Pause/Resume button on the Job screen to resume printing. Verify that the Unwinder is threaded correctly and speed is set correctly. Try to use stock that has soft-release tape holding the media to the cardboard core.
System Status: PAPERPATH_PAPERJAM NOTE: Depending on where the media stops/jams; it is also possible for the Printer to display: PAPERPATH_FEED_TIMEOUT	Media jam detected. Printer has detected that one (<i>or more</i>) Media Sensors are blocked (<i>interrupted</i>).	Carefully remove jammed media from Printer and close Print Engine. System Status message in red should go away. Touchscreen and Toolbox Paperpath Sensor indicators should change from red to green. After jam is cleared, you can: Label Rolls: Adjust Unwinder/Winder speed. Fanfold Labels: Check if labels are stuck together. Uncurl media. Tap Clear Error button and then tap the Pause/Resume button on the Job screen to resume printing.
System Status: MAINTENANCE_BUSY	Machine is performing a maintenance procedure.	No action required. Wait for the Printer to finish.

SECTION 5
TROUBLESHOOTING

Toolbox System Status Messages (*Continued*)

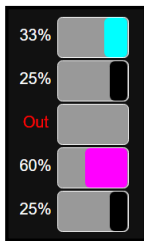
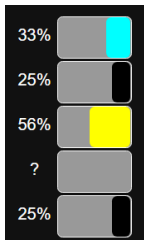
SYSTEM STATUS	SOURCE	SOLUTION
System Status: DOOROPEN_PRINTHEAD	<p>Indicates that Printhead Door is open.</p> <p>Switch damaged or disconnected.</p>	<p>Verify that Printhead Door is closed. Make sure that Printhead Door switch (<i>located at the back center of the door</i>) is activated when the Printhead Door is open and closed.</p> <p>Use Scan Sensors in the Printer Toolbox to check that the Printhead Door switch is functioning.</p>
System Status: DOOROPEN_INK	<p>Indicates that Ink Tank Door is open.</p> <p>Switch damaged or disconnected.</p>	<p>Verify that Ink Tank Door is closed. Make sure that Ink Tank Door switch (<i>located at the upper right corner of the door</i>) is activated when the Ink Tank Door is open and closed.</p> <p>Use Scan Sensors in the Printer Toolbox to check that the Ink Tank Door switch is functioning.</p>
System Status: DATA_PATH_UNDERRUN	<p>Media is not moving from the Entry Sensor to Exit Sensor within a specified time.</p> <p>Possible issue with format or orientation of job being sent.</p> <p>Dirty Encoder Wheel.</p>	<p>Check/clean the Media Transport Rollers. Check/clean the Sensors and Reflector.</p> <p>Try changing the orientation setting in software/driver or setting a different media size.</p> <p>If the problem persists contact technical support. They should check/clean the Encoder Wheel.</p>
System Status: INK_LOW_X	<p>One or more Ink Tanks are low on ink.</p> <p>X = Color.</p> <p>MULT = more than one Tank color.</p>	<p>Ink Tank replacement will be necessary soon. Reorder Ink.</p>
System Status: INK_OUT_YELLOW	 <p>One or more Ink Tanks are out of ink.</p> <p>X = Color.</p> <p>MULT = more than one Tank color.</p> <p>"Out" = System calculated that 250ml of ink was drawn from Tank or visible ink sensor sees no ink in Tank prism.</p>	<p>Open the Ink Tank Door. Replace empty Ink Tank(s).</p> <p>Verify that Ink Tanks are seated firmly and latches are fully closed.</p> <p>Close the Ink Tank Door and tap "Clear Error" button. The ink levels should fill in.</p> <p>NOTE: A premature visible ink "Out" condition can occur if the Printer is not on a sturdy, level surface.</p>
System Status: CARTRIDGE_MISSING_MULT or CARTRIDGE_MISSING_X	 <p>Ink Tank is missing or not recognized (<i>obtained from an unauthorized reseller</i>).</p> <p>X = color (C M Y K1 K2)</p> <p>MULT = more than one Tank color.</p>	<p>Insert the missing Ink Tank or pop Ink Tank in and out to improve connection. Check/clean the Ink Tank contacts.</p> <p>Tap Clear Error button and then tap Pause/Resume button on the Job screen to resume printing.</p>

Toolbox System Status Messages (Continued)

SYSTEM STATUS	SOURCE	SOLUTION
<p>System Status: MECH_FAIL_PERMANENT</p> <p>ERROR on System Status screen. Check the Printer Graphic to determine which component has a problem or failed: Service Station, Ink Valve or Printhead, (usually indicated with a steady “?”)</p>	<p>Mechanical error One of Printer's mechanical components was not properly registered at expected position. Mechanical failure or Sensor failure.</p>	<p>Visually inspect the component stated as a “Reason” for failure. Using the Scan Sensors page in the Printer Toolbox, perform toggle test on Sensor responsible for registration of failed mechanical component position. Try rebooting (<i>restarting</i>) the Printer. If problem persists call for Service.</p>
<p>System Status: [Crit 63 03-phead offline cancelpage restart]</p>	<p>Dirty/damaged Printhead contacts at Printhead or board.</p>	<p>Try rebooting (<i>restarting</i>) the Printer. Try replacing the Printhead. If problem persists call for Service.</p>
<p>System Status: ONLINE</p> <p>ERROR on System Status screen. Printer Graphic shows Printer Service Station as “?”.</p>	<p>Service Station position sensors are damaged or malfunctioning.</p>	<p>Check Service Station position. Check for mechanical jam. Try rebooting (<i>restarting</i>) the Printer. If problem persists call for Service.</p>
<p>System Status: MECH_CANCELPAGE</p>	<p>Job was cancelled by user pressing the Cancel Job button.</p>	<p>Wait until the print job has cleared from the Printer. Then manually clear job from the computer's print queue. Send a new print job.</p>
<p>System Status: PRINthead_MISSINGQA</p> <p>Printer Graphic shows Printer Printhead as “?”.</p>	<p>Printhead missing or Printhead not making proper connections.</p>	<p>Install Printhead. Remove the Printhead, clean the contacts and reinstall the Printhead. Replace the Printhead. Refer to appropriate sections in this manual for removing and installing Printhead Cartridge. Try rebooting (<i>restarting</i>) the Printer. If problem persists call for Service.</p>
<p>System Status: PRINthead_UNPRIMED</p>	<p>Printhead unprimed. Printhead Latch is open and/or the Door is open. Printhead priming process has failed.</p>	<p>After installing the Printhead you must close the Printhead Latch and close all doors to start priming process. Remove Printhead Cartridge; wet the print nozzles using distilled water and reinstall Printhead Cartridge. Refer to appropriate sections in this manual for removing and installing Printhead Cartridge. If you continue to have trouble priming the Printhead; check for kinked or pinched ink tubes. Try rebooting (<i>restarting</i>) the Printer. If problem persists call for Service.</p>

SECTION 5
TROUBLESHOOTING

Toolbox System Status Messages (*Continued*)

SYSTEM STATUS	SOURCE	SOLUTION
<p>System Status: WIPER OVERTEMP</p>	<p>Wiper Motor is overheated due to performing a Wiper Transfer (<i>removing excess ink off Service Station Wiper</i>) too often or for multiple or extended periods. Printer will continue maintenance after Wiper Motor cools down. Message will disappear once the temperature returns to operating range.</p>	<p>Wait for the Wiper Motor to cool down. The Printer will automatically resume operation.</p> <p>Tip: To reduce this issue; set the Mid-Job Servicing interval to a higher number of pages.</p> <p>NOTE: If the value is set too high, print quality issues may occur; caused by clogged or dehydrated nozzles.</p> <p>Run “Condition Wiper” from Touchscreen Wiper Menu. This rehydrates the Wiper Roller and Wiper Motor Module which may help to reduce energy it takes to turn the motor.</p>
<p>System Status: WIPER ERROR</p>	<p>Wiper Roller is not turning or is too hard to turn.</p> <p>Possible causes:</p> <ol style="list-style-type: none"> 1. Ink coagulation is making the motor hard to turn. 2. Wiper Motor cable is broken or disconnected. 3. Wiper Motor Module failure. 	<ol style="list-style-type: none"> 1. Run “Condition Wiper” from Touchscreen Wiper Menu. This will rehydrate the wiper roller and wiper motor module. 2. Check cable and connections. 3. Replace Wiper Motor Module. <p>If problem persists call for Service.</p>
<p>System Status: MAINTENANCE_JAM</p> <p>NOTE: To determine the error; check the Touchscreen to see if it displays one of the following messages.</p> <p>Sled Error – Service Station Sled</p> <p>Lift Error – Printhead Carriage Lifter</p> <p>Wipe Error – Wiper Motor</p>	<p>Printhead or Ink Tank Door opened during process.</p> <p>Motor that drives component has detected a problem or movement is impeded.</p>	<p>Close doors (<i>Printhead and Ink Tank</i>) and tap “Clear Error”.</p> <p>Check for anything that may be hindering movement of item (<i>Sled, Lifter, or Wiper</i>).</p> <p>If “Wipe Error”; run “Condition Wiper” to rehydrate the Wiper Roller.</p> <p>If “Sled Error” or “Lift Error”; check/clean the Sled and Lifter Home Sensors.</p> <p>If problem persists call for Service.</p> <p>CAUTION: After pressing “Clear Error”, the system will try to drive the sled, lifter or wiper motor again. If the same error comes up again, after trying the above solutions, call for service. Pressing “Clear Error”, more than a few times in a row, may cause system damage.</p>

Appendix A – Printer Specifications

PRINT RESOLUTION	Best: 1600 x 1600 DPI Normal: 1600 x 800 DPI
PRINT SPEED	Best: 6" (15 cm)/second Normal: Up to 12" (30 cm)/second
MEDIA PRINTSIZE	8.5" W x 75" L (215.9 mm x 1905 mm)
MEDIA TYPES	Roll or Fanfold (<i>Label, Tag</i>)
MEDIA SIZE	Minimum: 1" W x 1" L (25.4 mm x 25.4 mm) Maximum: 9" W x 75" L (228.6 mm x 1905 mm)
MEDIA THICKNESS	Minimum: 3 points (0.1 mm) Maximum: 12 points (0.3 mm)
MIN. LABEL GAP (Space between Labels)	No Bleed: 3 mm Full Bleed: 5 mm
MEDIA SENSING	Label gap, notch, tick mark, (Continuous, blackmark, diecut)
SOFTWARE	Windows™ Printer Drivers for Windows™, 8, 8.1, 10. RIP available
DIAGNOSTICS	Viewable on 7" Touchscreen Display and L-Series Toolbox
DATA STORAGE	Onboard Printer storage for Job Library
INK	Water-based ink. 5 individual 250 ml ink tanks (CKMYK) Cyan, Yellow, Magenta, and two Black. LP2-21 Cyan, LP2-22 Yellow, LP2-23 Magenta, LP2-24 Black
INK MONITOR	Viewable on 7" Touchscreen Display and L-Series Toolbox
PRINT CARTRIDGE	Memjet® Replaceable Printhead
INTERFACE	USB 2.0 and Ethernet
ELECTRICAL	100-240 VAC, 50/60 Hz
INTERNAL MEMORY BATTERY	CR 2032 Lithium Battery
DIMENSIONS	20.25" W x 22.25" L x 13.5" H (51.4 cm x 56.5 cm x 34.3 cm)
WEIGHT	75 lbs. (34 kg)

All Specifications Subject To Change Without Notice

Appendix B – Supplies

The following supply items are available from your Formax Dealer:

SUPPLIES	
Printhead Cartridge	LP2-20
Black Ink Cartridge, 250 ML	LP2-24
Cyan Ink Cartridge, 250 ML	LP2-21
Magenta Ink Cartridge, 250 ML	LP2-23
Yellow Ink Cartridge, 250 ML	LP2-22

Appendix C – Borderless Printing: Borderless Print vs. Oversize

L-Series Print Driver (under *Printing Preferences*) offers two ways for printing to the edge of the media, sometimes called “**borderless**” or “**full-bleed**” printing. Each option adjusts the relationship between the target image, selected media size and the actual media on which it is printed, but in different ways. Each option has advantages and disadvantages, especially for certain types of images.

- **Borderless Print checkbox:** In **General Tab**, under **Media** section.
- **Oversize checkbox:** In **Custom Sizes** dialog box, under **Size** section in **General Tab** of **Print Preferences**.

Details about each option: when to use each, prerequisite setup and other tips for getting the best result.

BORDERLESS PRINT CHECKBOX

Borderless Print Checkbox is located in **Printers Printing Preferences**, in **Media** section under **General Tab**.

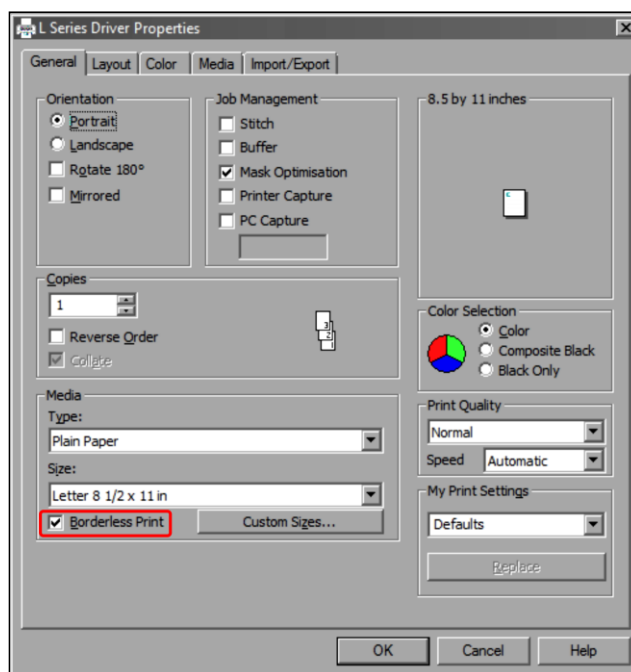

Borderless Print Checkbox on General Tab in Printing Preferences

Impact of Using Borderless Print

Selecting **Borderless Print checkbox** scales target image beyond the size of selected media, by adding a **Borderless** default resolution value set in the Printer Driver. The image is stretched to print larger than actual size.

For example, if the **Borderless** default setting is *21 (dots)*, then resultant **Borderless Print** selection will have a resolution of *821 dpi*, (when printing with normal resolution of *800*). Although this might stretch the image beyond the edges of the media, (and is quick and easy to select), it may be too distorted to use.

APPENDICES

Prerequisites for Borderless Print

Since scaling can distort the image, do not use **Borderless Print** for targets that have barcodes or text because this setting could render them unreadable. If target image is a photograph or other graphical image, scaling may not be noticeable or objectionable. Make test runs and check effect of choosing **Borderless Print**.

For example, **Borderless Print** for a 4" x 8" label would actually be:

$$4'' (800 \text{ dpi}) + 21 \text{ dots} = 3221 \text{ dots} \times 8'' (800 \text{ dpi}) + 21 \text{ dots} = 6421 \text{ dots}$$

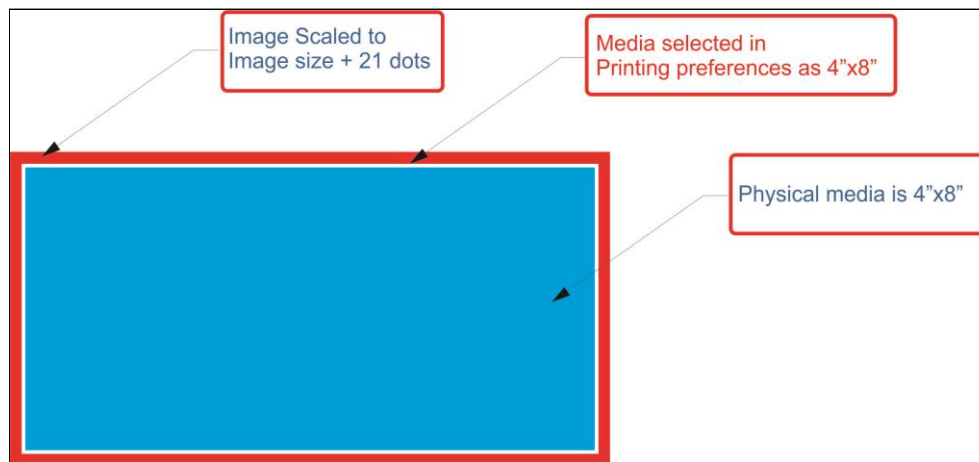

Borderless Print Example: Measurements and Relationships

For barcodes and text, use **Oversize** instead **Borderless Print**.

Required preparation for **Oversize** is explained below.

OVERSIZE SETTINGS

Oversize checkbox is in **Custom Sizes** dialog box, located in **Printing Preferences** under **General Tab**.

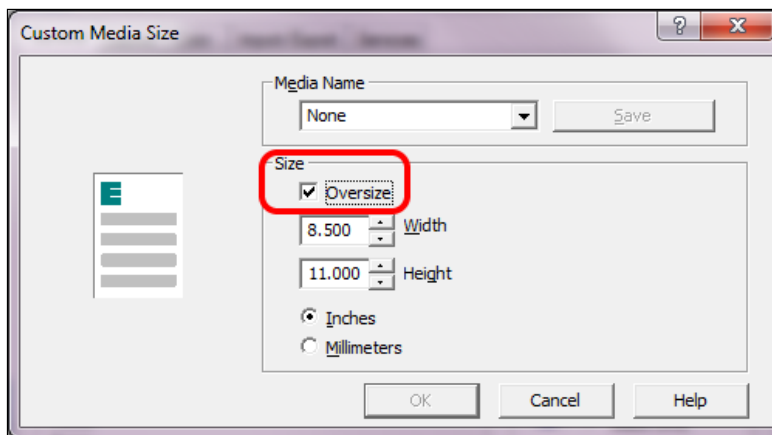

Oversize Checkbox on Custom Media Size Dialog Box

- Select **Oversize** checkbox.
- Enter measurements of physical media in Width and Height fields, selecting units (*inches or millimeters*).

Page Setup for Oversize

When using **Oversize** option, **Resizing** (located in *Layout Tab of Driver*) needs to be set to “Original Size”.

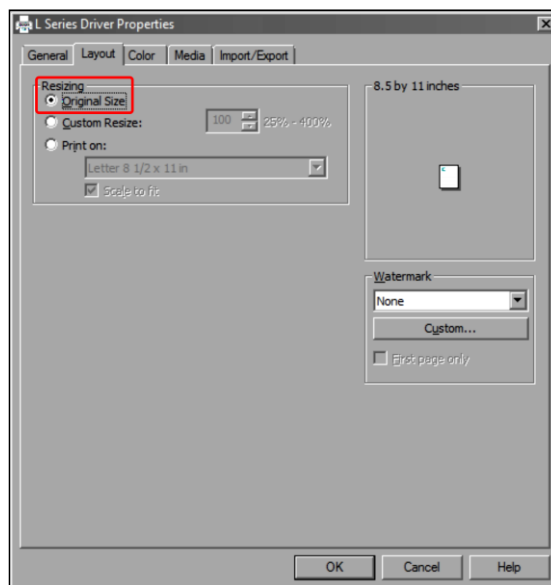

Page Setup for Oversize Option

Impact of Using Oversize

Selecting **Oversize** extends **Custom Sizes** dimensions beyond that of actual media being printed on. Since this size extension is equal in both X- and Y- axes, there is no distortion of target image. Instead, choosing **Oversize** opens up more of target image for printing, so that it can print beyond size of physical media. However, target image also needs to be created as oversized, not size of physical media; otherwise, there is likely to be a white border between image and media.

Prerequisites for Oversize

To make **Oversize** an applicable option:

- Target image needs to be greater in size than size of actual media. Image needs to be same size as custom media size selected in **Custom Sizes** window, corresponding to additional amount set as default in Driver.

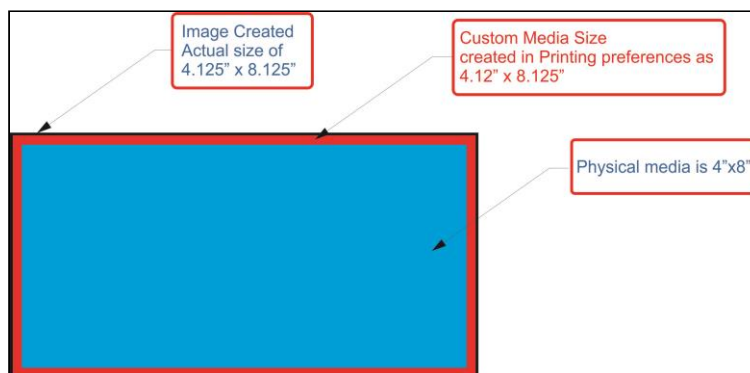

Oversize Example: Measurements and Relationships

APPENDICES

ADDITIONAL CONSIDERATIONS AND TIPS

Some additional considerations apply to both **Borderless Print** and **Oversize** in certain circumstances.

Minimum Label Gap and Maximum Width

For both **Borderless Print** and **Oversize**, additional consideration and testing are required when approaching limitations for minimum label gap and maximum label width.

- **Minimum label gap is 3mm.** If media used has only a 3mm gap between labels, borderless printing (*either **Borderless Print** or **Oversize***) may not work without skipping a label between printed labels. An image that goes beyond physical media size effectively reduces label gap, possibly below 3mm minimum. This may also be beyond **top of form (TOF)** and **bottom of form (BOF)**. If gap is less than minimum label gap, labels are skipped since **TOF** and **BOF** are undetectable for next label.
- **Maximum print width is 8.69"**, including physical media width + **Borderless Print/Oversize** additional width. If borderless printing is required, physical media needs to be narrow enough to include additional width for **Borderless Print** or **Oversize** expansion.

Page Sizing and Handling with Adobe Acrobat

Many target images are in PDF format. When printing from Adobe Acrobat, be sure to select only **Actual Size** under **Page Sizing & Handling**. Other options will affect settings already made for **Borderless Print** and **Oversize**, producing undesirable results.

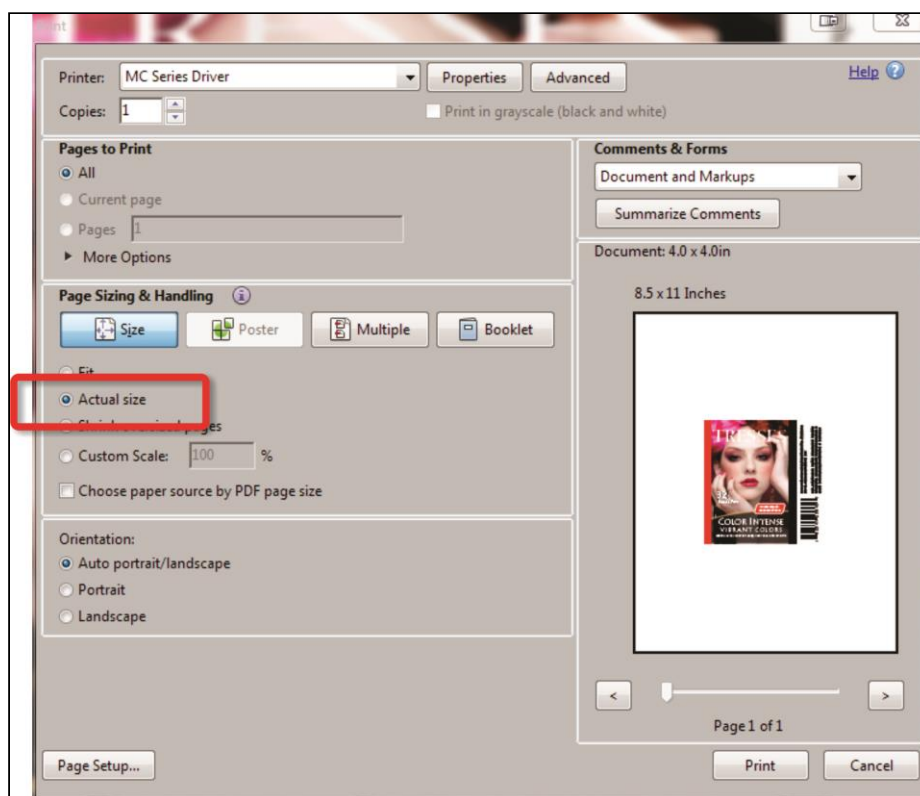

Printing Borderless Print/Oversize from Adobe Acrobat: Select “Actual Size”

-
- A**
- Adapter Plate**
- Unwinder 11
 - Winder 11
- Adjust Core Size 27
- Adjust Tension, Winder 29
- Adjustable**
- Media Guide 2
 - Media Sensor 2, 4
- Adjusting Speed, Unwinder & Winder 29
- Auto/Manual Switch 6
- B**
- Borderless Print vs. Oversize Printing 84
- C**
- Cartridges**
- Ink Tank 5, 21, 62, 74
 - Printhead 3, 22, 64, 73
- Choose Location 8
- Clamshell** 1, 2
- Latch 4
 - Support Strut 4
 - Switch 4
- Clean**
- Ink Drip Tray 72, 73
 - Ink Revolvers 72
 - Ink Tank Contacts 63
 - Media Sensors 72
 - Print Engine 72
 - Printer 71
 - Printhead 64
 - Rollers 71, 72
 - Service Station 69
- Color Tab, Printer Driver 33
- Connect**
- Computer 13
 - Network 2, 13
 - Optional Unwinder/Winder 26
 - Printer 13
 - USB 2, 13, 15
- Control Panel**
- Power Button 1, 2
 - Touchscreen 1, 2, 37
 - USB Port 1, 46
- Couplings, Ink Revolver 3
- Cover, Top 1, 2
- Cutter Assembly 1
- D**
- Date and Time, Toolbox 55
 - Debug Logs, Toolbox 58
 - Diagnostics, Toolbox 54
- Display, Touchscreen 1, 2
 - Disposal, Ink Tanks 63
 - Door, Ink Tank 1, 2
 - Drip Tray 4
- Drop-Down Menu**
- Job (Status) 38
 - Maintenance 42, 61
 - Media Scan 43, 59
 - Paperpath 42
 - Service 61
 - Setup 41
 - System Test 45
 - Test Print 41, 61
 - Toolbox 48
 - Touchscreen 37
 - Videos 46
 - View 48
 - Wiper 45
- E**
- Encoder 4
 - Error Messages 77
 - Ethernet Port 2
 - Exhaust Fans 1, 4
 - Exit Sensor 4
 - Exit Wheels 4
 - External Device, Connect 25
 - External Power Connector 6, 7
- F**
- Fanfold Labels 30
 - Fans, Exhaust 1, 4
 - Forwarding Rollers 2, 4
 - Forwarding Wheels Assembly 2
- Fuse**
- Main 2
 - Unwinder 6
 - Winder 7
- G**
- General Tab 32
- Guides**
- Adjustable Media 1, 2
 - Fixed Media 2
 - Media Exit 1
- H**
- Hub Assembly**
- Adjust Core Size 27
 - Unwinder 6
 - Winder 7
- I**
- Import/Export Tab, Printer Driver 36
-

Ink Drip Tray

Clean	72, 73
Install	10
Location	4

Ink Revolvers

Clean	72
Location	3

Ink Tanks

Clean Contacts	63
Disconnect Switch	5
Disposal	63
Door	1, 2
Install	21
Latches	1, 5
Remove/Replace	62, 74
Storage	63

Ink Usage, Toolbox

Ink Waste Tray

Inspection Motor.....

Install

Ink Drip Tray Assembly	10
Ink Tanks	21
Printer Driver	14
Printer Driver Over USB	14
Printer Driver, Network Version A	16
Printer Driver, Network Version B	19
Printhead, First Time	22
Unwinder Adapter Plate.....	11
Winder Adapter Plate.....	11

Interconnect Port, Unwinder.....

Interconnect Port, Winder.....

Interface Port

Connecting	25
External Device.....	2
Unwinder	2

J

Jams, Printer

Job (System Status), Touchscreen

Job Library, Print

Job Logs, Toolbox

L

Label Roll Spindle

Label Tension Arm.....

Label Tension Guide Shaft.....

Labels

Fanfold	30
Loading	27
Roll-to-Cut	26, 30
Roll-to-Roll.....	26, 27

Latches

Clamshell	1, 4, 5
Ink Tanks	1, 5
Printhead	3

Layout Tab.....

Library

Print Job	39
Video.....	46

Lifter Motor

Load Media.....

Location, Choose

Logs

Debug Files	58
Job Files	58

M

Main Power Switch

Maintenance

Printer	62
Schedule.....	92
Toolbox.....	61
Touchscreen.....	42

Media Guide Ring

Media Guides

Adjustable	1, 2
Exit.....	1
Fixed	2

Media Scan

Toolbox.....	59
Touchscreen.....	41, 43

Media Sensor

Adjustable Entry	2, 4
Clean	72
Exit.....	4

Media Tab, Printer Driver.....

Media, Load.....

Minimum Requirements, System

Misfeeds

Mode Switch, Unwinder.....

N**Network**

Connect.....	2, 13
Settings, Toolbox	55
Settings, Touchscreen	41

O

Operating Printer

Optional Hardware

P

Package Contents.....

Paperpath, Touchscreen.....

Platen, Print

Power Button

Power Connect.....

Power Connector, External

Power Switch, Winder.....

Print Engine

Clamshell	1, 2
Clean	72

Ink Revolvers	3, 72	Return Procedure	68
Latch	1, 5	Service Life.....	67
Latch, Clamshell	4	Storage	67
Service Station	3	Troubleshooting	75
Printer		Printing	
Clean	71	Fanfold Labels	30
Connect	13	Roll-to-Cut Labels	26
Connect Unwinder/Winder	26	Roll-to-Roll Labels	26
Cutter Assembly	1	R	
Drip Tray	4	Receptacle, Power	2
Encoder	4	Remove Shipping Materials	9
Ethernet Port	2	Remove/Replace	
Exit Wheels.....	4	Ink Tanks	62, 74
Firmware Updates, Apply	46	Ink Waste Tray.....	70
Fuse, Main	2	Jams, Printer.....	70
Ink Drip Tray Assembly	10	Printhead	64, 73
Ink Tanks	1, 5	Roll Labels.....	26, 27
Interface Port.....	2	Rollers	
Jams	70	Clean	71, 72
Main Power Switch.....	2	Exit.....	4
Maintenance.....	62	Forwarding.....	2, 4
Operating	31	Transport.....	4
Optional Hardware.....	83	Roll-to-Cut Labels	26, 30
Print Platen.....	4	S	
Receptacle, Power.....	2	Scan Sensors, Toolbox	60
Set-up.....	8	Schedule, Maintenance.....	92
Shipping/Transporting	73	Sensor	
Specifications.....	82	Adjustable Media Entry	2, 4
Supplies.....	83	Clean	72
Support Strut.....	4	Exit.....	4
Touchscreen.....	1, 2, 37	Service	
Transport Rollers	4	Life, Printhead	67
Troubleshooting	76	Toolbox.....	54, 61
Unpack.....	8	Service Station	3
USB Port	2	Clean	69
Using Print Job Library.....	39	Inspect.....	69
Video Library.....	46	Inspection Motor.....	3
Printer Driver		Set-up	
Borderless Print vs. Oversize	84	Change Core Size.....	27
Color Tab	33	Network, Toolbox.....	55
General Tab.....	32	Network, Touchscreen	41
Import/Export Tab	36	Printer	8
Install	14	Touchscreen	41
Layout Tab.....	33	Shipping Material Removal.....	9
Media Tab	34	Shipping/Transporting Printer	73
Network Install, Version A	16	Specifications, Printer.....	82
Network Install, Version B	19	Speed Adjust, Unwinder & Winder.....	29
Properties	31	Speed Control	
USB Install.....	14	Unwinder	6, 29
Printhead	3	Winder	7, 29
Clean	64	Spindle Lock.....	6, 7
Install First Time.....	22	Starwheel Assembly, Exit.....	4
Latch	3	Storage	
Lifter Motor	3	Ink Tanks	63
Remove/Replace	64, 73		
Return Policy	67		

Printhead	67
Supplies, Printer	83
Support Strut.....	4
Switch	
Clamshell	4
Ink Tank Disconnect.....	5
Main Power.....	2, 13
On/Off.....	13
System Requirements, Minimum	14
System Settings, Toolbox	55
System Status, Toolbox	49
System Test, Touchscreen	45
T	
Tension Control, Winder	29
Test Print	
Toolbox.....	61
Touchscreen.....	41
Toolbox	
Date and Time.....	55
Debug Logs.....	58
Diagnostics	54
Drop-Down Menu.....	48
Ink Usage	53
Maintenance Drop-Down Menu	61
Media Scan	59
Scan Sensors	60
Service Drop-Down Menu.....	61
Service Menu	54
System Settings.....	55
System Status.....	49
Test Print Drop Down Menu.....	61
User Interface.....	50
Using.....	48
View Drop-Down Menu	48
Top Cover.....	1, 2
Touchscreen	
Control Panel USB Port.....	1
Display	1, 2
Drop-Down Menu.....	37
Job (System) Status.....	38
Maintenance.....	42
Media Scan	41, 43
Network Configuration	41
Paperpath	42
Setup	41
System Test.....	45
Test Print.....	41
UI Updates, Apply	46
USB Port, Control Panel.....	46
Using.....	37
Using Media Scan	43
Using Stored Jobs	39
Videos	46

Wiper	45
Transport Rollers	4
Tray, Drip	4
Tray, InkWaste	1
Troubleshooting	75
Errors and Warnings	77
Printer	76
Printhead.....	75
U	
Unpack.....	8
Unwinder	6
Adapter Plate.....	11
Auto/Manual Switch	26
Upload	
Print Jobs	46
Video Files.....	46
USB Port	
Control Panel	1, 46
Printer Connection	2, 13, 15
User Interface, Toolbox.....	50
Using	
Control Panel USB Port.....	46
Media Scan, Toolbox	59
Media Scan, Touchscreen	43
Media Tab Printing Adjustments	35
Printer Toolbox	48
Printer Touchscreen	37
Stored Jobs-Printer's Job Library	39
V	
Videos, Touchscreen	46
View, Drop-Down Menu	48
W	
Warning Messages.....	77
Waste Tray, Ink	5, 70
Wheels Assembly, Top Forwarding	2
Winder	7
Adapter Plate.....	11
Tension Control	29
Tension Control Selector	7
Wiper, Touchscreen.....	45

PRINTER MAINTENANCE SCHEDULE

General, periodic maintenance is needed to keep the Printer in good working order. Many tasks can be performed by operators with basic supplies, no special tools needed. Other tasks should only be performed by trained service personnel. **NOTE:** High volume usage may require more frequent maintenance.

Maintenance Supplies & Equipment: Flashlight, small telescoping mirror, hard-bristled toothbrush or equivalent, powder-free nitrile gloves, protective clothing and eyewear, small flathead screwdriver, tweezers, vacuum with wand, deionized distilled water, can of compressed air, foam or lint-free cotton swabs, lint-free wipes, disposable shop towels.

COMPONENTS/TASKS	MAINTENANCE TYPE				
	DAILY	BI-WEEKLY	MONTHLY	YEARLY	AS NEEDED
PERFORMED BY OPERATOR					
Printhead (Manual Wiping)					WIPE
Ink Revolver Couplings and Connections: Inspection/Cleaning					EVERY PRINTHEAD REMOVAL
Residue and Debris Removal	CLEAN	CLEAN	CLEAN	CLEAN	CLEAN
Optical Sensors (Media Path)		CLEAN	CLEAN	CLEAN	
Wiper Assembly: Inspection		INSPECT	INSPECT	INSPECT	
Ink Tank Latches/Ink Bay				INSPECT	
Ink Tubing, Couplings, Components			INSPECT	INSPECT	
Ink Drip Tray	CLEAN WEEKLY OR AS NEEDED				
Ink Waste Tray			INSPECT	INSPECT	REPLACE
Printhead Lift Motor Belts and Service Station Belts			INSPECT	INSPECT	
PERFORMED BY SERVICE TECHNICIAN					
Lubrication				APPLY	APPLY
Pen Driver PCA Contacts: Cleaning					EVERY PRINTHEAD REMOVAL
Moving Parts/Motor				TEST	
Service Station Sled Assembly				CLEAN	
Wiper Assembly: Cleaning				CLEAN	

WARNING!

ALWAYS POWER DOWN PRINTER BEFORE CONNECTING OR DISCONNECTING ANY WIRING HARNESSSES OR CABLE CONNECTIONS TO AVOID SERIOUS SHOCK OR INJURY.

CAUTION

- ALWAYS USE APPROPRIATE PERSONAL PROTECTION EQUIPMENT (PPE).
- USE ELECTROSTATIC DISCHARGE (ESD) PROTECTION WHEN MAINTAINING EQUIPMENT.
- DISPOSE OF ALL MAINTENANCE WASTE IN ACCORDANCE WITH LOCAL REGULATIONS.

