

FORMAX[®]

Atlas C300
Auto-Feed High-Speed Creaser/Folder

OPERATOR MANUAL
First Edition

INDEX

INTRODUCTION & SPECIFICATION

The Atlas C300 Creaser and Perforator **PAGE 4**

SAFETY Do's & Don'ts 5

THE Atlas C-300

Labeled Photograph **7**

THE SWITCH PANEL

Detailed diagram and description **8**

Features on the switch panel **9**

OPERATING THE Atlas C300

Adjusting the Papergate **10**

Setting the Suction Slot **10**

Setting the Vacuum Bleed **11**

Setting the Adjustable Side Lay **11**

Setting the Back-Stop **11**

Setting the Air Distribution **11**

Setting the Air Separation Pressure **11**

Setting the Positions of the Drive Wheels and Hubs **12**

TOUCHSCREEN OPERATION

Touchscreen Layout **14**

Paper Settings Page **15**

Roller Gap Set & Tilt Mechanism Page **17**

Crease Settings Pages

Creases in 'Set By Fold' mode **20**

Creases in 'Set By Position' mode **21**

Fold Settings Pages

Folds in 'Set By Fold' mode **23**

Folds in 'Set By Position-' mode **24**

Example of 'Set By Position' mode **26**

Delivery Settings Page **27**

Status Screen **29**

Running the Job **30**

Setting the machine to operate in manual sheet feed mode **31**

Store Pages **32**

Tools Menu **35**

Touchscreen Calibration **36**

Deflect Trim Adjustment **37**

THE BLADE ASSEMBLY

Adjusting the blade pressure **38**

INDEX

REPLACING CREASING BLADE SETS	
Installing new blade sets	PAGE 39
Spare Blades	42
PERFORATING	
Equipment, Spares	43
Setting the machine	44
Recommended Position of the Drive Wheels and Hubs	45
REMOVING PAPER JAMS	46
TROUBLE SHOOTING	
Paper crease out of square	47
Crease Position Inaccuracy	47
Paper fold out of square	47
Paper Jamming	47
Machine will not start	48
Paper not feeding	48
Cracking of the printed material along the crease	48
Using the Correct Blade Set	49
ERROR SCREENS	
01 Sheet did Not Arrive	50
02 Paper Crunch	50
03 Double Sheet Feed	50
04 Blade Not Home	50
05 Blade Busy	51
06 Blade Home Failure 1	51
07 Blade Home Failure 2	51
08 Flying Home Failure	52
09 Clip 1 NOT Clear	52
10 Clip 1 NOT Blocked	52
11 Clip 2 NOT Clear	52
12 Clip 2 NOT Blocked	53
13 Overlap	53
DISPATCH KIT	60
ACCESSORIES AND OPTIONS	61
RECOMMENDED SPARES	62 - 63
MACHINE CALIBRATION HISTORY SHEET	64
FUSE POSITIONS & RATINGS	65
PRODUCT RECYCLING AND DISPOSAL	66

INTRODUCTION

INTRODUCTION AND SPECIFICATION

It is **IMPORTANT** to note that to prevent cracking, when using dry ink or toner based print engines, the material **must** be fully acclimatised for at least 48 hours before putting an image onto the paper.

IMPORTANT the operating environment should be controlled to a temperature between 16° C and 27° C Maximum.

Specification

Feeding System	Bottom suction feed
Max. Sheet Size	700mm x 385mm (27.5" x 15") [900mm x 385mm (35.4" x 15") with Optional extension table].
Min. Sheet Size	210mm x 140mm (8.3" x 5.5") (dependant on stiffness of paper and type of fold).
Max. Paper Thickness	0.40mm (varies according to hardness, type of fold, and substrate).
Min. Paper Thickness	0.11mm (varies according to hardness, type of fold, and substrate).
Max. No. Creases per Sheet.....	9
Max. No. Folds per Sheet.....	2
Max. No. Stored Programmes	Unlimited
Min. Repeat Crease Distance.....	40mm (1.6")
Min. Repeat Fold Distance	70mm (2.75") (depending on paper weight)
Min. Crease Distance from Leading Edge.....	50mm (1.96")
Min. Fold Distance from Leading Edge	50mm (1.96") (depending on paper weight)
Min. Crease Distance from Tail Edge.....	50mm (1.96")
Min. Fold Distance from Tail Edge	50mm (1.96") (depending on paper weight)
Min. Fold Length	70mm (2.75")
Speed per Hour (A4 in half).....	6000 sheets

Note: The production speed varies according to the material size and the fold type.

Dimensions	L: 2020mm H: 1265mm W: 680mm L: (79.5") H: (49.8") W: (26.8")
Weight	190Kgs (+50Kgs packing)
Power Requirement	1 phase 230v 50Hz 1 phase 220v 60 Hz
Sound Power Level	80.0 decibels

*As part of our continued product improvement plan, specifications and information published in this manual are subject to change without notice.

All specifications are dependant on application, type of stock, temperature, relative humidity, RH and print engine used.

Specifications quoted were measured on uncoated and unprinted stock. E & OE.

Safety Do's & Don'ts

Safety Do's & Don'ts

REGLES DE SECURITE : « A FAIRE » ET « A NE PAS FAIRE »

- Do - read this operator manual fully before operating the machine.**
Lire ce mode d'emploi avant d'utiliser la machine.
- Do - operate with the designated AC current only. Use an exclusive outlet, as overloading may cause fire or an electric shock.**
Respecter l'alimentation électrique indiquée. Brancher sur une prise séparée car une surcharge peut entraîner un incendie ou un choc électrique.
- Do - install the power cord out of the way to avoid a tripping hazard.**
Installer le cordon d'alimentation de manière à ne pas pouvoir trébucher par dessus.
- Do - make sure that the mains inlet connector is always easily accessible.**
Ménager un accès libre à la prise de courant.
- Do not - install the machine in an unstable place such that it tilts or shakes.**
Ne pas installer la machine sur une surface non plane, afin d'éviter qu'elle ne penche ou ne vibre.
- Do not - unplug the plug or unplug the power cord from the outlet with a wet hand, this can cause an electric shock.**
Ne pas installer la machine sur une surface non plane, afin d'éviter qu'elle ne penche ou ne vibre.
- Do not - unscrew and remove any covers from the machine, as it can cause an electric shock or injury.**
Ne démonter et enlever aucun carter de la machine, par crainte de décharge électrique ou de blessure.
- Do not - place receptacles containing liquids on any surface.**
Ne pas placer de récipient contenant un liquide sur la machine.
- Do not - adjust any part of the machine whilst rollers are running**
N'effectuer aucun réglage pendant que les rouleaux fonctionnent.
- Do not - operate the machine with loose or trailing clothing or loose hair.**
Ne pas porter de vêtements flottants et rassembler les cheveux longs lors de l'utilisation de la machine.
- Do not - under any circumstances adjust the paper gate when the machine is switched on.**
En aucune circonstance, régler le séparateur de papier lorsque la machine est branchée.

Warning Labels

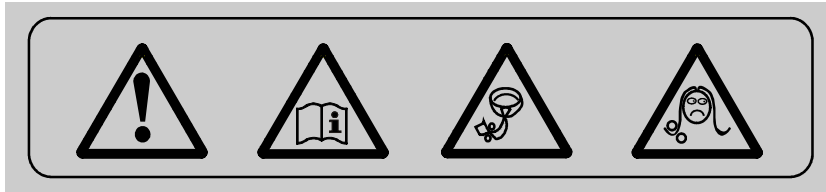

Do - be aware of any finger traps and rotating parts when operating the machine.

Attention au risque de se coincer les doigts, et aux pièces en mouvement lors du fonctionnement de la machine.

Do - read this operator manual fully before operating the machine.

Lire ce mode d'emploi avant d'utiliser la machine.

Do not - operate the machine with loose or trailing clothing.

Ne pas porter de vêtements flottants lors de l'utilisation de la machine

Do not - operate the machine with loose hair.

Rassembler les cheveux longs lors de l'utilisation de la machine.



Do - be aware of any finger traps and rotating parts when operating the machine.

Attention au risque de se coincer les doigts, et aux pièces en mouvement lors du fonctionnement de la machine.

Do - be aware of sharp points and blades.

Attention aux éléments tranchants et aux couteaux.

Do - be aware of rotating rollers.

Attention aux rouleaux en fonctionnement

Do - be aware of low current anti-static shock.

Attention aux faibles chocs d'électricité statique

Atlas C300 Creaser Folder

Key to photograph below

- | | | | | | |
|---|-----------------------|----|---------------------|----|--------------------------|
| 1 | Delivery assembly | 6 | Air Separation Knob | 11 | Paper Gate |
| 2 | Vacuum bleed knob | 7 | Adjustable side lay | 12 | Top cover |
| 3 | Suction slot knob | 8 | Back stop | 13 | Touchscreen |
| 4 | Switch panel | 9 | Fixed side lay | 14 | Optional Extension Table |
| 5 | Air distribution knob | 10 | Fuses | | |

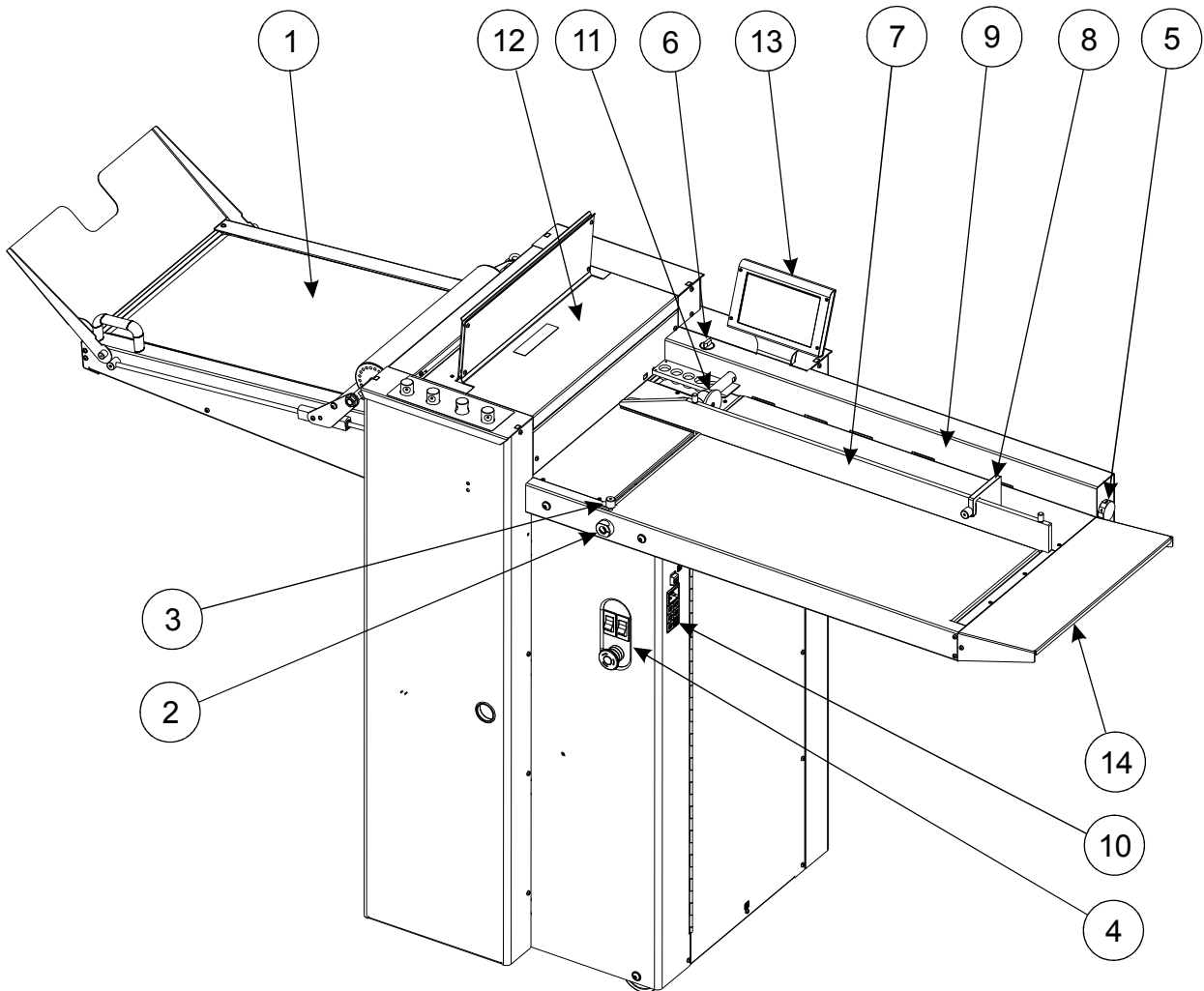

The Switch Panel

The Switch Panel houses the Compressor switch, System switch, and an industry standard Emergency Stop switch which will stop all power going to the machine when activated.

THE SWITCH PANEL

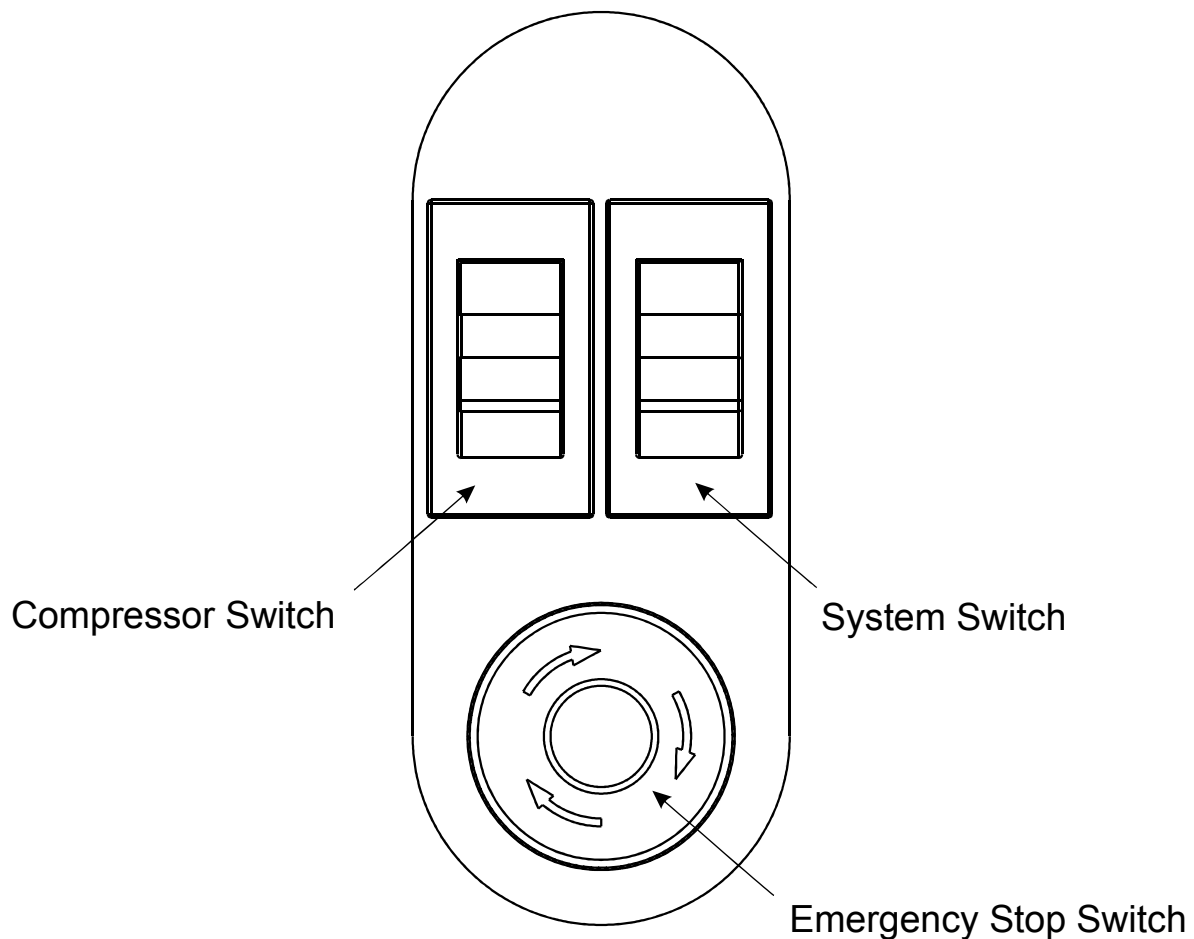

Features on the Switch Panel

System switch

When activated the system switch will operate the motors in order to begin the creasing sequence.

Compressor switch

Allows the operator to switch off the compressor unit in order to utilise the machine to manually feed sheets.

Operating the Atlas C300

Adjusting the Paper Gate

Set the height of the Paper Gate to approximately two thicknesses of paper, by turning the disc j. An excessive gap is a most likely cause of double sheet feeding.

This setting is only intended as a guide, for instance, sheets with an upward curl will require this setting to be increased.

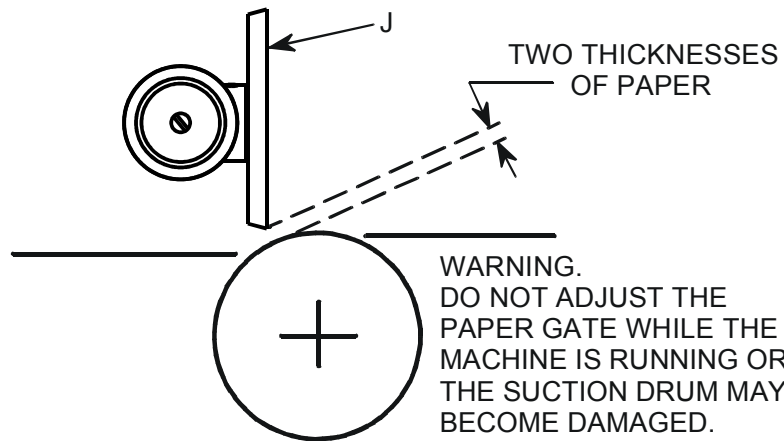

Setting the Suction Slot

The suction slot is located inside the vacuum roller and can be adjusted by releasing and moving the suction knob horizontally in either direction to the required position.

For light stocks set the knob to the left and for heavier stocks set the knob to the right.



Setting the Vacuum Bleed

Situated on the front of the feed table, the Vacuum Bleed Knob is used to allow more control of the suction on the vacuum drum.

When light weight paper is being fed through the machine turn the knob clockwise to reduce the possibility of marking, or damage to the leading edge of the paper.

Setting the Adjustable Side Lay

Place the paper stack on to the loading table and slide up to the fixed side lay and paper Gate. Release the clamps located at each end of the side lay and slide up towards the paper stack as demonstrated in fig 10.1. Allow a gap of approximately 0.5mm (1/64 inch) between the paper and the side lay.

Setting the Back Stop

Position the backstop and slide up towards the paper stack allowing a gap (as specified in the above step).

Setting the Air Distribution

Depending on the length of the sheet to be creased, the air distribution knob can be rotated to various positions in order to supply air to different ports. Position 2 is recommended for most sheet sizes. However, a better result may be obtained by using the settings below or by experimentation.

- Position 1** - For sheets longer than A3 (17") in order to supply air to the centre of the stack, ports 2, 3 and 4 open.
- 2** - For A5 sheets or 8 inches long, ports 1 and 2 open.
- 3** - For A4 sheets or 11 inches long, ports 1 and 3 open.
- 4** - For A3 sheets or 17 inches long, ports 1 and 4 open.
- 5** - For sheets longer than A3 (17") in order to supply air to the ends of the stack, ports 1 and 5 open.
- 0** - For sheets longer than A3 (17") in order to supply air evenly along the stack, ports 1, 3 and 5 open.

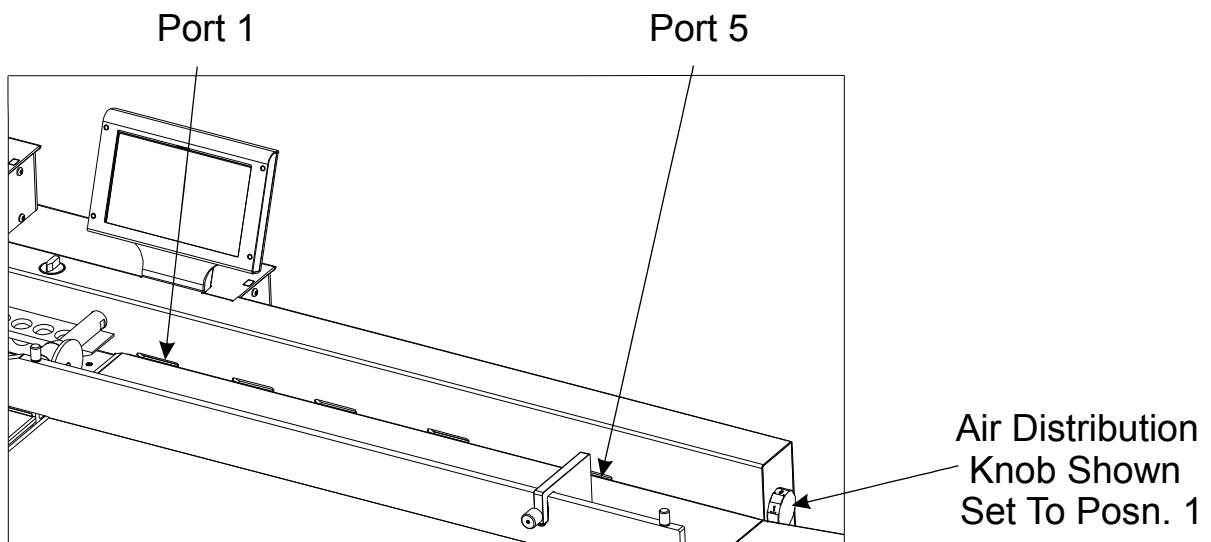

Setting the Air Separation Pressure

To control the amount of air supplied to the ports, the air separation knob can be rotated clockwise to decrease the pressure or anti-clockwise to increase the pressure.

Operating the Atlas C300

Setting the positions of drive wheels and hubs

It is important that the drive wheels and drive hubs, on the roller shafts, are arranged across the width of the media being creased; this is done to ensure that the media is accurately driven and supported through the rollers. A suggested layout, **when Folding**, is shown below (see FIG 15.1). The suggested layout, **when perfining**, is different, and is shown on page 45 (see FIG 38.1).

The drive wheels and hubs are fixed to the rollers by grub screws.

FIG 15.1

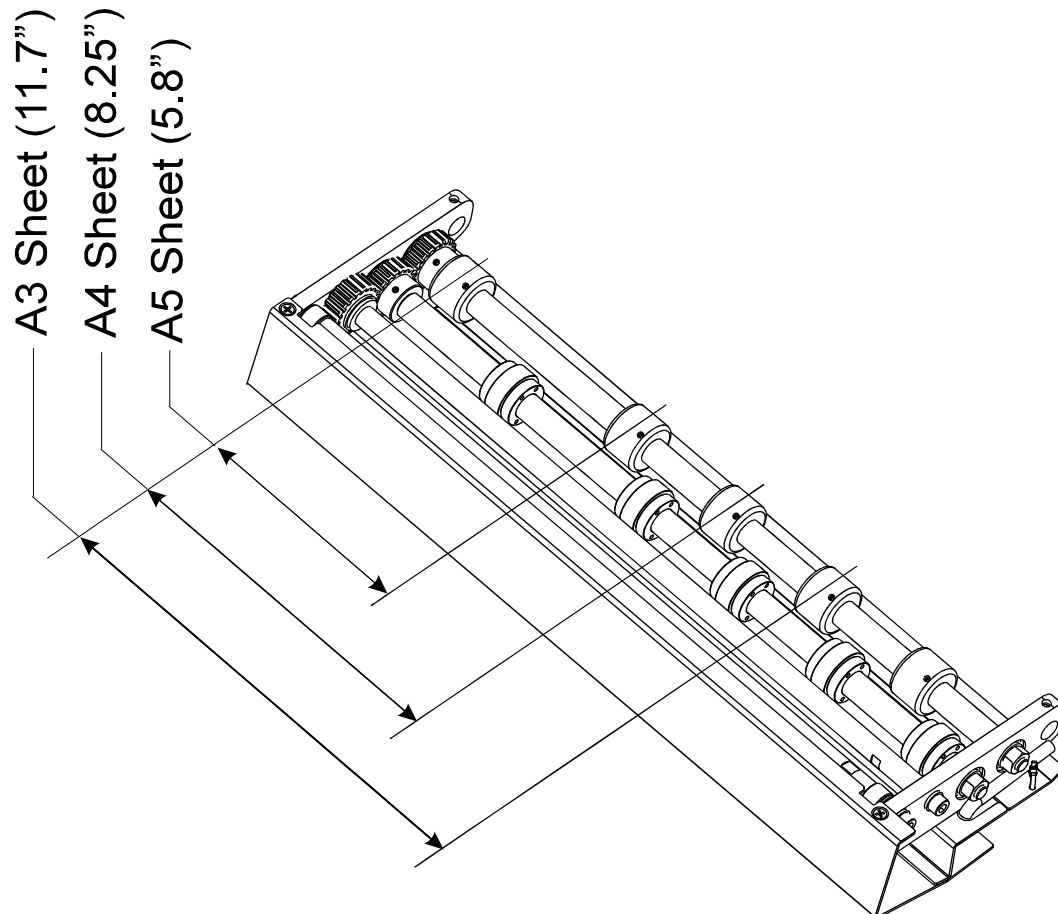

WHEEL & HUB ARRANGEMENT, (WHEN FOLDING)

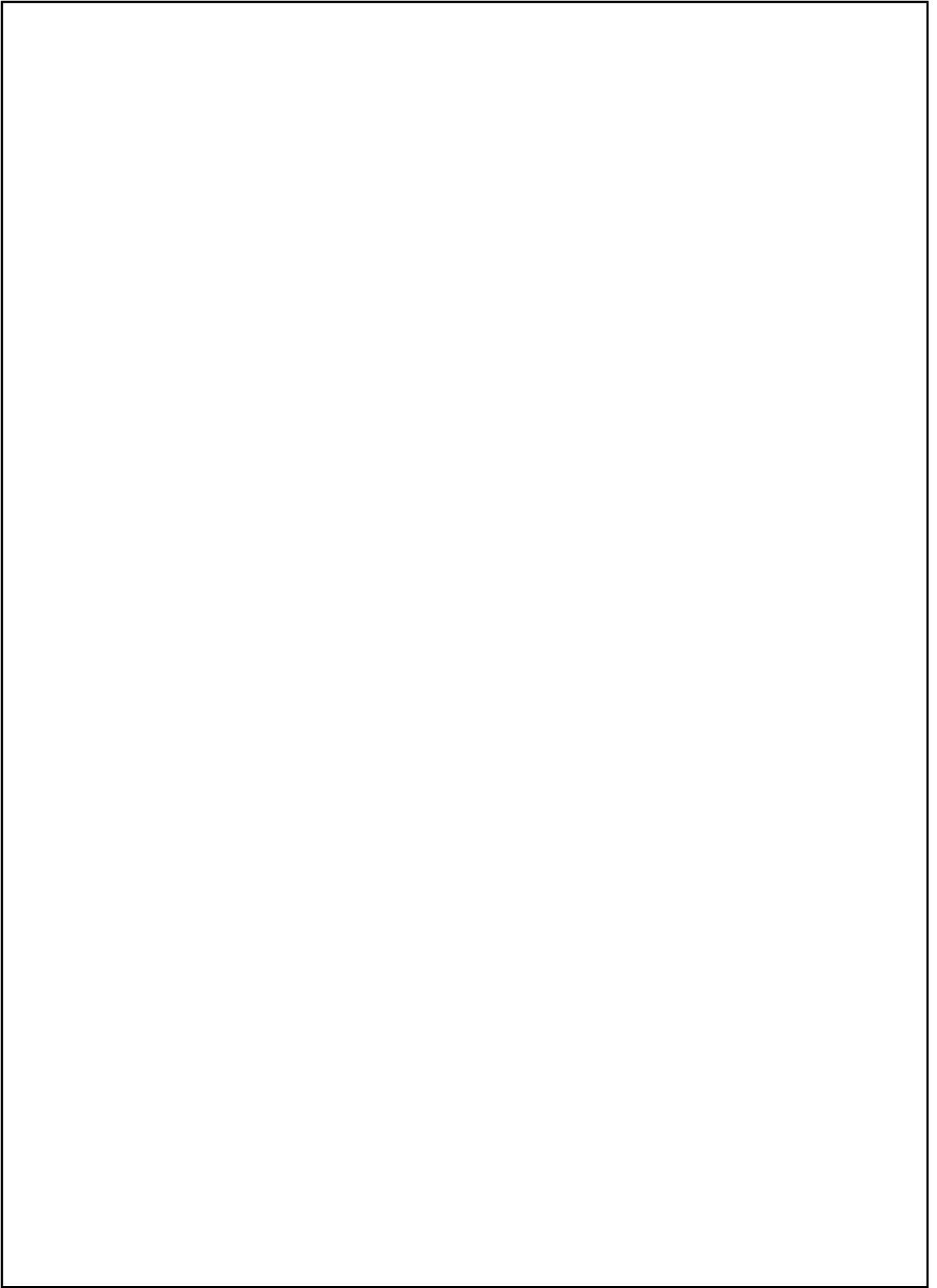

Operating the Atlas C300

TOUCHSCREEN OPERATION

1. Turn the Emergency Stop button clockwise to switch the power on. After the system start up procedure the touch screen will be displayed as shown below.

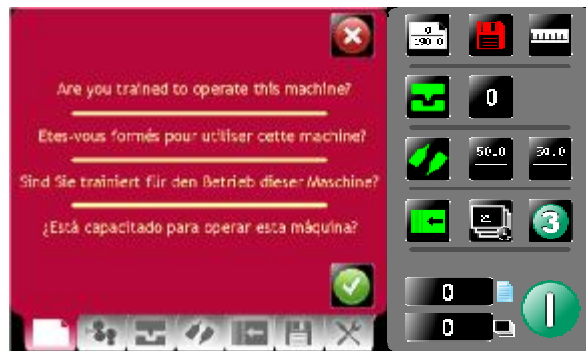

IMPORTANT.

If you have not been trained to operate this machine, we strongly advise that you select the red cross icon.

We recommend that you either seek training or ask a trained operator to run the machine for you.

Select the green tick icon only if you have been trained to operate this machine.

If you have not been trained to operate this machine and you select the green tick icon, Morgana Systems Ltd accept no responsibility for personal injury, damage to the machine or damage to materials being processed by the machine.

WARNING:-

Wait at least 10 seconds, after making any selection on the Touchscreen panel, before switching the machine OFF. Failure to do so could result in the data storage being corrupted, and the machine not operating.

The touch screen is laid out into 3 main areas as shown below:

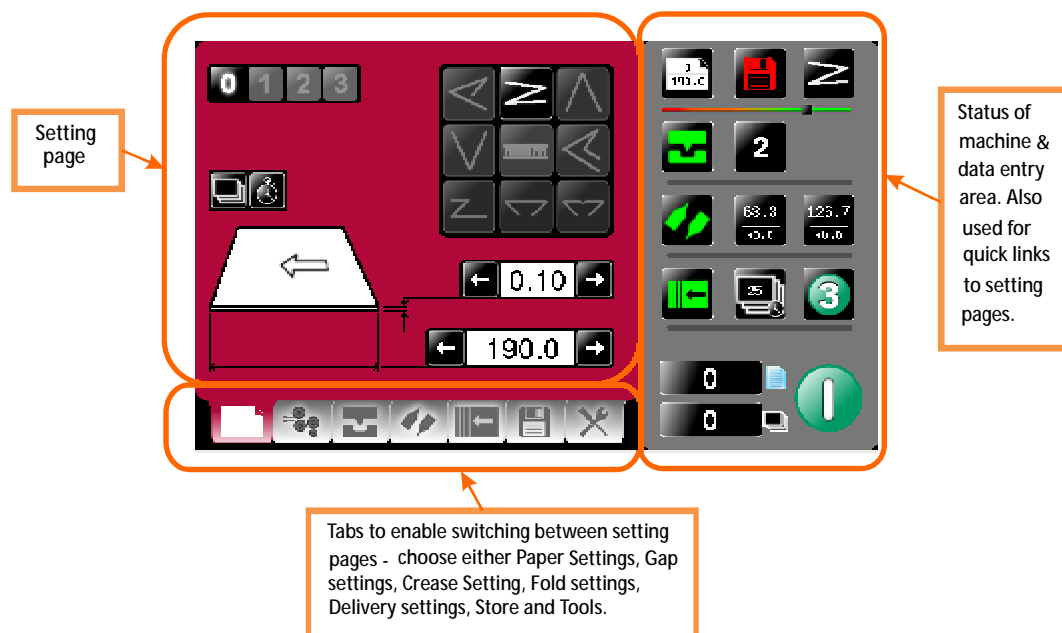

Setting Pages.

Paper settings Page

Paper Type - As a guide choose as follows:

- 0 - approx 0.1 thk
- 1 - approx 0.2 thk
- 2 - approx 0.3 thk
- 3 - approx 0.3+ thk

See Page 25

Batch Button - Image is identical to that shown in the status area. On selection the status area is replaced with a calculator for inputting new values. Batch sizes of 1 to 998 may be set.

Toggle between, Delay between batches and stop after batch

Fold Selection - For quick setting of fold positions on standard size sheets.

Highlighted fold is type currently selected, other folds may be selected. Currently selected fold is shown in the status area.

NOTE:-

Select the Ruler Icon to set Fold positions manually ('Set by Position' mode).

Page Thickness - On selection of status area is replaced with a calculator for inputting new values

Range = 0.1 to 0.4mm
Increments of 0.01mm

Arrows may be selected to increase or decrease the page size in 0.1mm increments

Paper Length - On selection the status area is replaced with a calculator for inputting new values. Length range = 190mm - 900mm

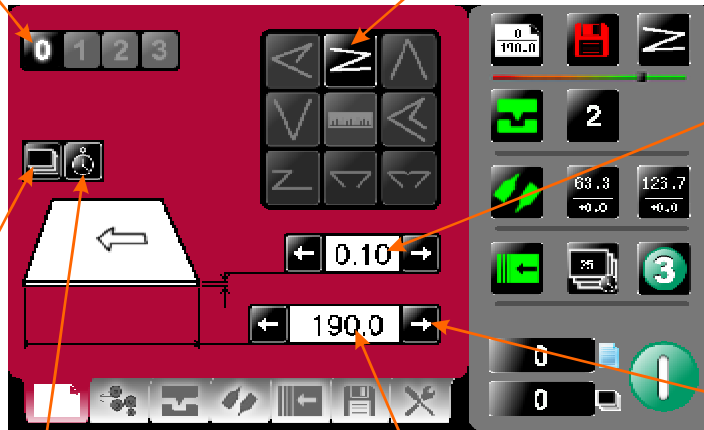

Paper size Selection.

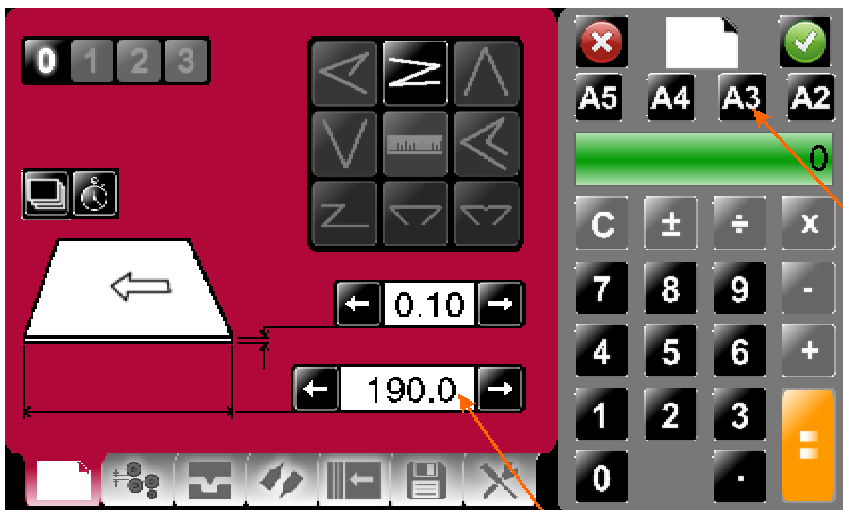

Pre-set Paper sizes for quick insertion - Standard sizes for country origin would be shown.

Paper input

Operating the Atlas C300

Batch size Selection.

0 1 2 3

← 0.10 →

← 190.0 →

25 50 100 200

Pre-set Batch sizes for quick insertion.

Paper Thickness input

Paper Thickness Selection.

0 1 2 3

← 0.10 →

← 190.0 →

0.1 0.2 0.3 0.4

Pre-set Paper Thickness sizes for quick insertion.

Roller Gap Set & Tilt Mechanism Page.

To get to the roller gap setting page click the lower tab 
 Roller gaps may be in the range of 0.05mm to 1.5mm, with increments of 0.05mm

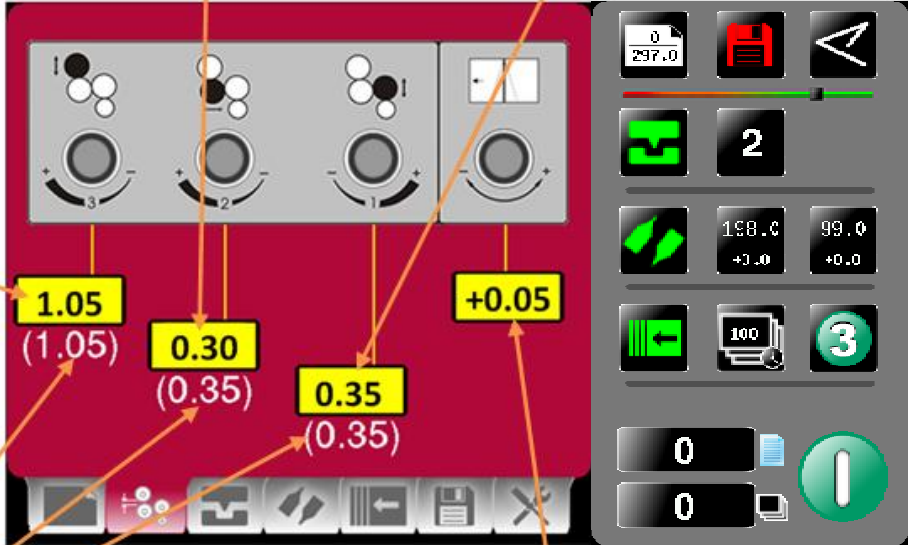

The screenshot shows the control panel with the following settings and callouts:

- Current gap setting for 2nd Fold Roller:** 0.30 (0.35)
- Current gap setting for 1st Fold Roller:** 0.35 (0.35)
- Current gap setting for 3rd Fold Roller:** 1.05 (1.05)
- Current set Tilt Angle:** +0.05
- Recommended gap values - based on paper thickness:** 1.05, 0.30, 0.35

Setting the Roller Gaps (Gap 1, Gap 2 & Gap 3)

The roller gaps can be adjusted to suit the thickness of the material being creased or folded; and the type of fold being produced. The roller gaps may also require adjustment if cracking of the print is noticeable. (see Fig 13.1 below).

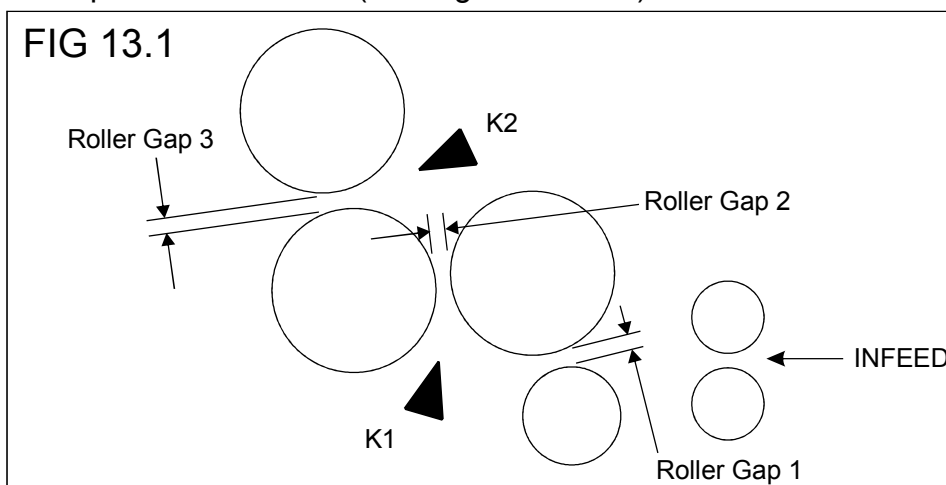

The gap settings (Gap 1, Gap 2 & Gap 3) can then be adjusted by rotating the Roller Gap Set Knobs (see FIG 10.1 on page 10).

IMPORTANT.

When setting roller gaps, you **must** first adjust the gap to a value greater than that required and then decrease the value to the required setting. (Do not set the gap, from a value lower than that required).

PROCEDURE. (FOR SET BY POSITION).

NOTE. Use the on screen guide for Set by Fold.

- (i) Measure the thickness of the sheet using a Digital Vernier Calliper.
- (ii) Set roller GAP 1 to the vernier reading.
- (iii) Set roller GAP 2 and roller GAP 3, (for the type of fold being produced), using the GAP SET GUIDE table shown below.

GAP SET GUIDE				
	FOLD TYPE	GAP 3	GAP 2	GAP 1
Half Fold on Knife 1 →	Half K1	2X	2X	X
Half Fold on Knife 2 →	Half K2	2X	X	X
	Letter	3X	X	X
	Concertina	3X	X	X
	Gate	3X	X	X
	Closed Gate	3X	X	X
	Engineering	3X	X	X
	Double	4X	2X	X

Example 1:- When producing a **Half K1** fold, if GAP 1 is 0.2 (X) then set GAP 2 to 0.4 (2 x X) and set GAP 3 to 0.4 (2 x X).

Example 2:- When producing a **Gate** fold, if GAP 1 is 0.3 (X) then set GAP 2 to 0.3 (X) and set GAP 3 to 0.9 (3 x X).

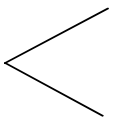
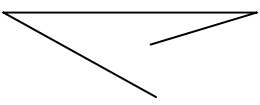
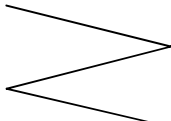
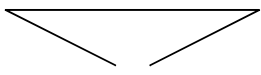
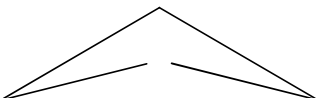
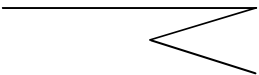
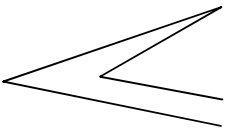
FOLD TYPES		
		
HALF	LETTER	CONCERTINA
		
GATE	CLOSED GATE	ENGINEERING
		
DOUBLE		

Setting the Blade Tilt Mechanism

The blade tilt mechanism has been designed to compensate for when the creasing position on the sheet is not square. This could be due to an inaccuracy in the media or an unexplained feed issue. The mechanism will be set to zero (square) when the machine is supplied. The Blade Tilt Mechanism can be adjusted if necessary by rotating the Blade Tilt Knob (see FIG10.1 on page 10).

Operating the Atlas C300



Crease Settings Pages.

To get to the crease setting page click the lower tab



or from the status area.

If you have selected a predefined standard Fold Type from the paper settings page the crease positions will be set for you. These positions can be fine tuned by ± 0.1 mm

increments by pressing the arrow buttons   for each crease.

Creases in 'Set By Fold' mode.

Crease trim - On selection the status area is replaced with a calculator for inputting new values.

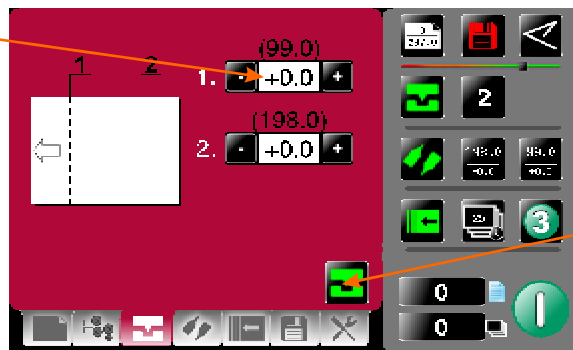

Crease on/off selector green is on & red is off. This is also indicated in the status area.

Trimming creases in 'Set By Fold' mode.

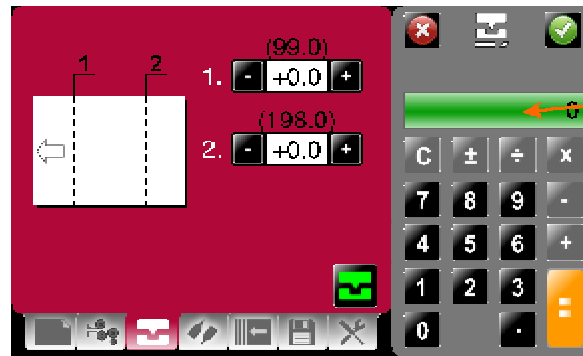

Creases may be trimmed by 0.1mm increments within the range of 5.0mm to +5.0mm.

Turn creasing off.

Greyed out area indicates the trim is not selectable

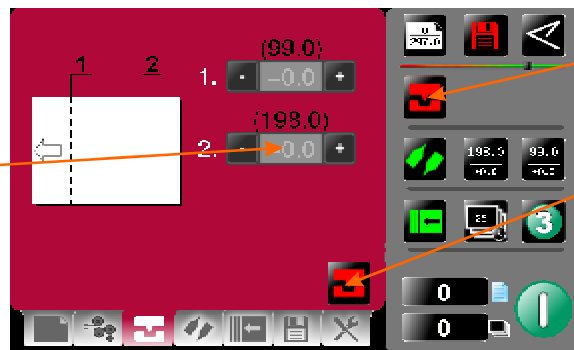

Status shows creasing off icon

This button toggles creasing on & off.

Operating the Atlas C300

Creases in 'Set By Position' mode.

Arrows may be selected to increase or decrease the page size in 0.1mm increments

Crease position - On selection the status area is replaced with a calculator for inputting new values, a maximum of 9 creases can be added.

Press to remove all creases - you will be asked to confirm deletion.

Number of creases - if more than 6 creases are added a scroll bar will appear for to enable viewing of all creases. Also shown in status area.

Plus box for inserting additional creases. On selection following creases will move down by one place a maximum number of 6 creases can be seen at any one time further creases can be accessed by use of the scroll bar.

Cross box for deletion of crease. On deletion of crease following creases will move up by one place. You will be asked to confirm deletion of the crease.

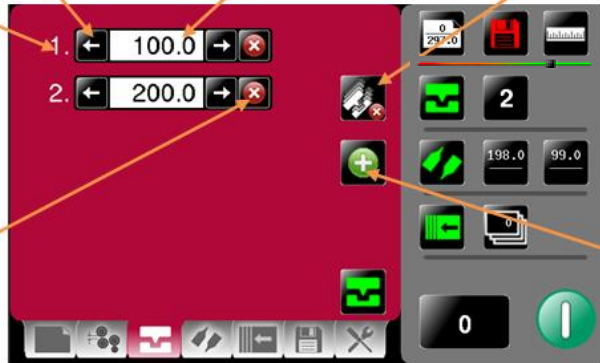

Additional creases added - scroll bar appears for more than six creases.

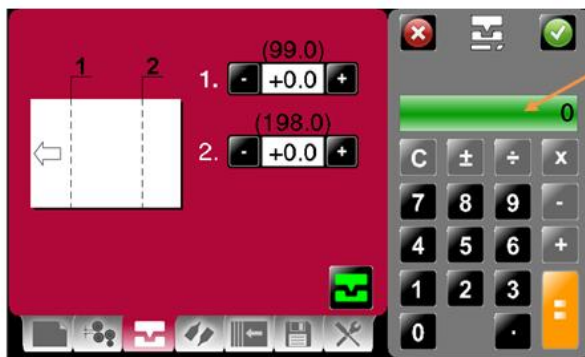

Creases may be trimmed by 0.1mm increments within the range of 5.0mm to +5.0mm.

Operating the Atlas C300

Turn crease on/off.

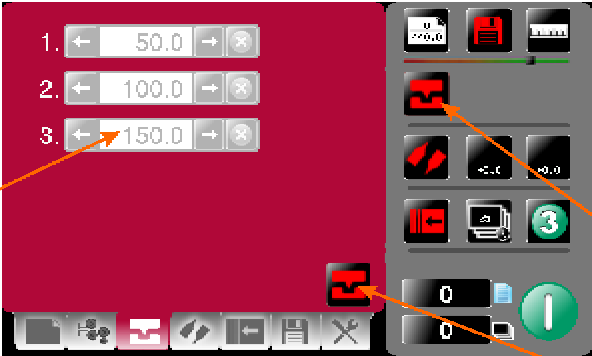

1. ← 50.0 → ⊗

2. ← 100.0 → ⊗

3. ← 150.0 → ⊗

Greyed out area indicates the trim is not selectable

Status shows creasing off icon

This button toggles creasing on & off.

Detailed description: This screenshot shows the main configuration screen of the Atlas C300. On the left, there are three input fields for crease distances: 50.0, 100.0, and 150.0 mm. The 150.0 mm field is highlighted with an orange arrow. On the right, there is a vertical toolbar with several icons. A red icon with a white crease symbol is highlighted with an orange arrow. Below it, a green icon with a white crease symbol is also highlighted with an orange arrow. At the bottom of the screen, there is a row of icons for various functions.

Individual deletion of crease confirmation screen.

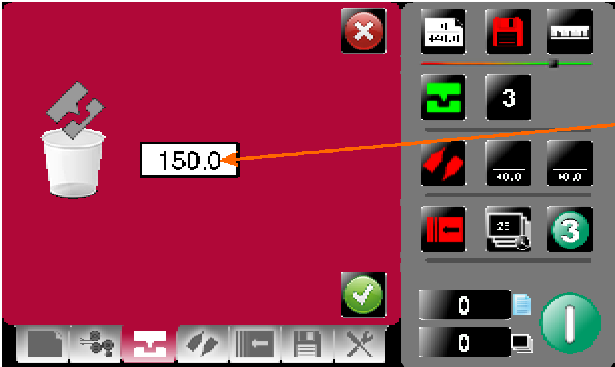

Crease 150 mm from lead edge will be deleted.

Detailed description: This screenshot shows a confirmation screen for deleting a specific crease. The screen has a red background. On the left, there is a white trash can icon with a piece of paper being thrown into it. To the right of the trash can is a white input field containing the number '150.0'. An orange arrow points from the text box to this input field. On the right side of the screen, there is a vertical toolbar with several icons. A green icon with a white crease symbol is highlighted with an orange arrow. At the bottom of the screen, there is a row of icons for various functions.

Remove all creases confirmation screen.

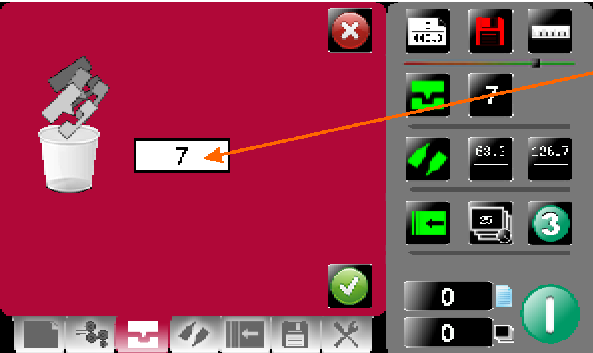



All creases - in this case 7 off will be deleted.



Detailed description: This screenshot shows a confirmation screen for deleting all creases. The screen has a red background. On the left, there is a white trash can icon with several pieces of paper being thrown into it. To the right of the trash can is a white input field containing the number '7'. An orange arrow points from the text box to this input field. On the right side of the screen, there is a vertical toolbar with several icons. A green icon with a white crease symbol is highlighted with an orange arrow. At the bottom of the screen, there is a row of icons for various functions.

Operating the Atlas C300

Fold Settings Pages.

To get to the Fold setting page click the lower tab  or  from the status area.

If you have selected a predefined standard Fold Type from the paper settings page the crease positions will be set for you. These positions can be fine tuned by $\pm 0.1\text{mm}$

increments by pressing the arrow buttons   for each crease.

Folds in 'Set By Fold' mode.

K1 Fold trim - On selection the status area is replaced with a calculator for inputting new values.

Trim range is -5.0 to +5.0 with increments of 0.1mm

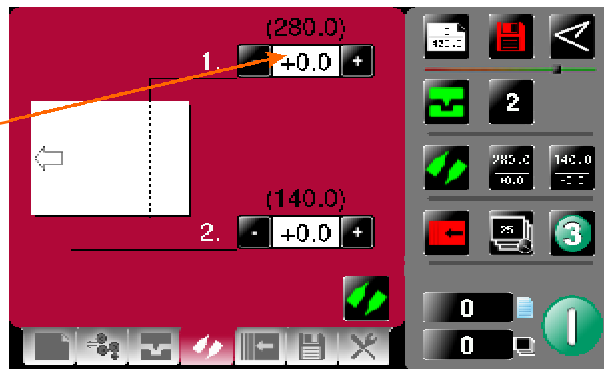

Folding can be trimmed for fine adjustments.

Trim range is -5.0 to +5.0 with increments of 0.1mm

With Folding turned off the defect positioned can be trimmed.

Trim range is -5.0 to +5.0 with increments of 0.1mm

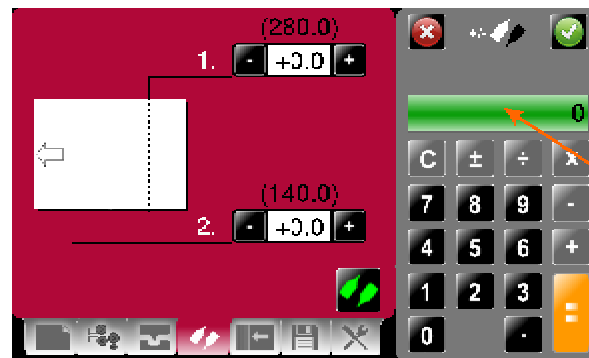

Folding on/off selector green is on & red is off. This is also indicated in the status area.

Operating the Atlas C300

Folds in 'Set By Position' mode.

Fold distance from lead edge for knives (K1 & K2) increments of 0.1mm

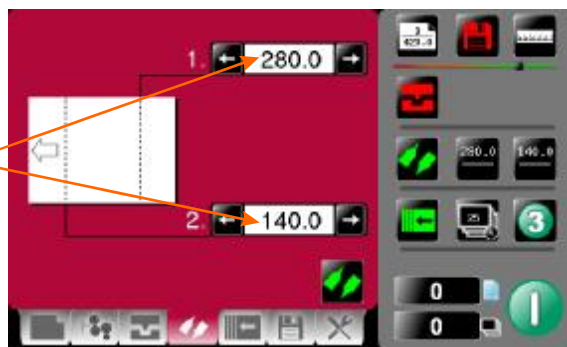

K1 deflect button

K1 micro adjust selected

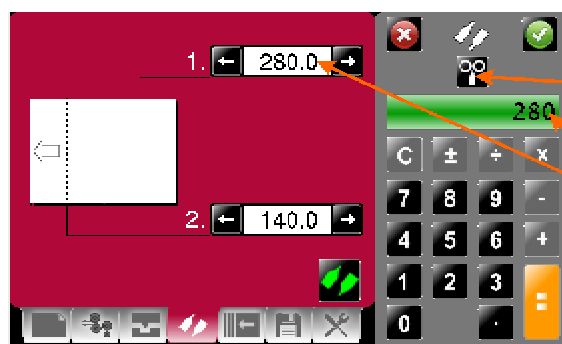

K1 in deflect position.
This can be micro adjusted.
Trim range is -5.0 +5.0
with increments of 0.1mm

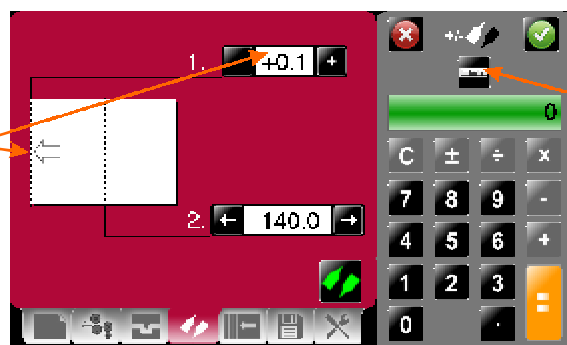

Clicking this icon switches deflect off & K1 returns to its original position.

K1 & K2 in deflect position.
This can be micro adjusted.
Trim range is -5.0 +5.0
with increments of 0.1mm

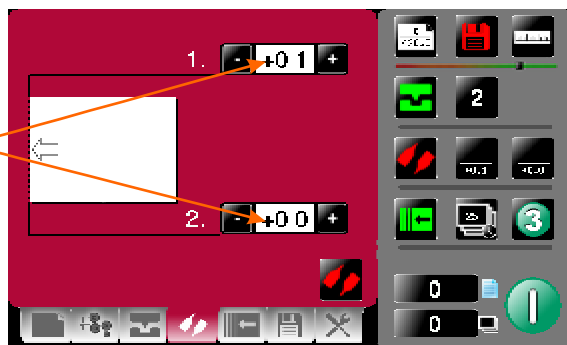

NOTES:-

If a crease position is adjusted, the fold will move with it.

If a fold position is adjusted, then only the fold will move.

Adjust a fold only if the fold appears to be giving an out of square or inconsistent result.

The fold is probably too close to the centre of the crease and will be trying to fold from one side of the crease to the opposite side of the crease, or wandering between one side of the crease to the other. (see below for explanation).

Paper Type - 0, 1, 2 and 3, is a fold compensation for variations in paper thickness, hardness and substrate.

I Paper type '0' - The crease and fold are set at exactly the same position. This may be used but beware some thin stocks will allow the fold to wander from one side of the crease to the other. (Use trims to overcome this).

I Paper type '1' '2' and '3' will move the fold relative to the crease and should be tried out with the stock in use.

Generally a higher number will be best for a thicker stock, but some settings will swap the fold from one side to the other side of the crease, this enables the user to choose the side that the crease will be seen. For example, on a front cover. .

SET BY POSITION

IMPORTANT NOTES.

1. If the fold is too near, or on the center line of the crease; the fold may try to fold diagonally across the crease profile and pull the fold out of square to the paper.

The best fold squareness is achieved when the fold is not on the center line of the crease, it should be to one side of the crease center line as shown below.

Unless the blade is on the bottom or knife 2.

Thus for a crease setting of 100 for example, the fold should be set to a figure slightly smaller or greater than 100.

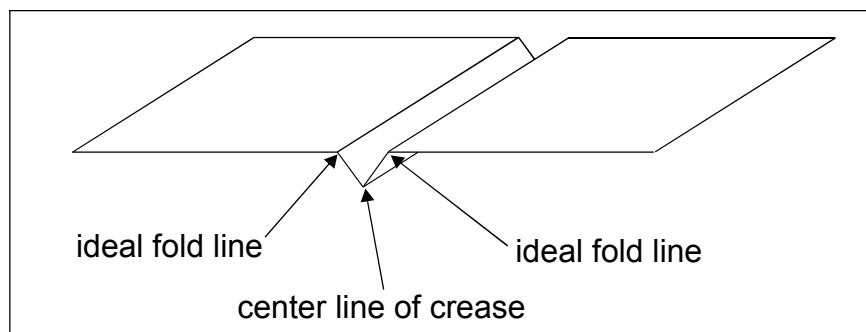

2. When using **Set By Position**, all dimensions are from the leading edge of the paper as shown in the example on page 26.

Example of Set by Position.

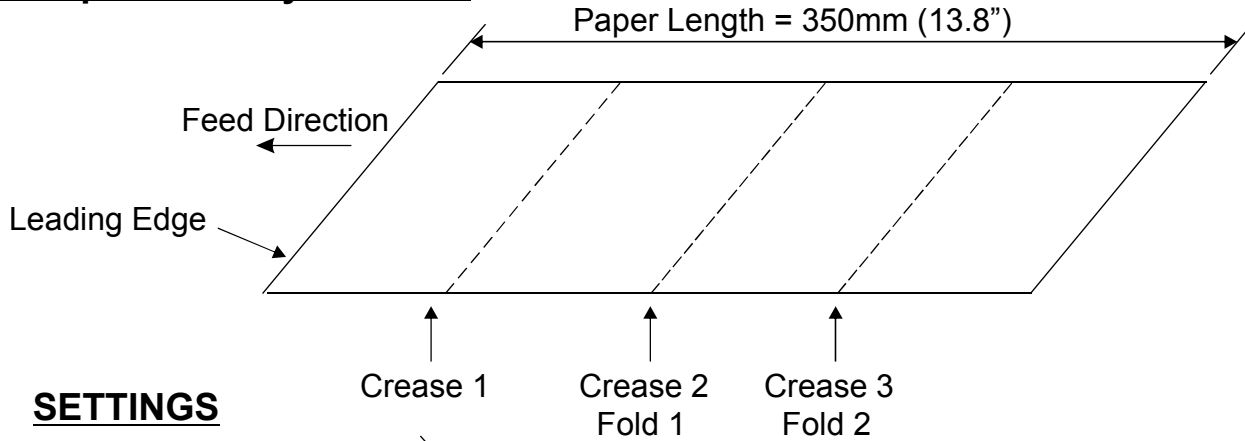

SETTINGS

- Crease 1 = 97.0mm (3.8")
 - Crease 2 = 179.0mm (7")
 - Crease 3 = 260.0mm (10.2")
 - Fold 1 = 179.0mm (7")
 - Fold 2 = 260mm (10.2")
- All dimensions are from the leading edge of the paper

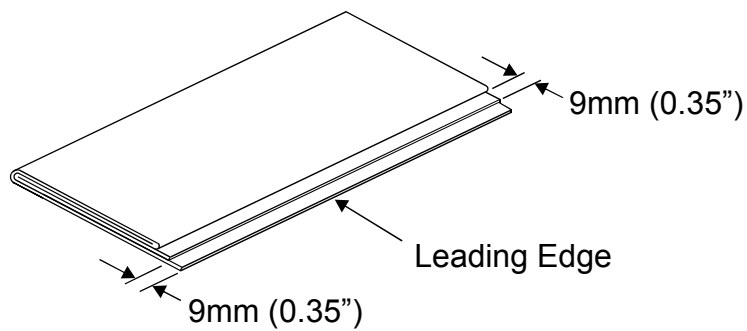
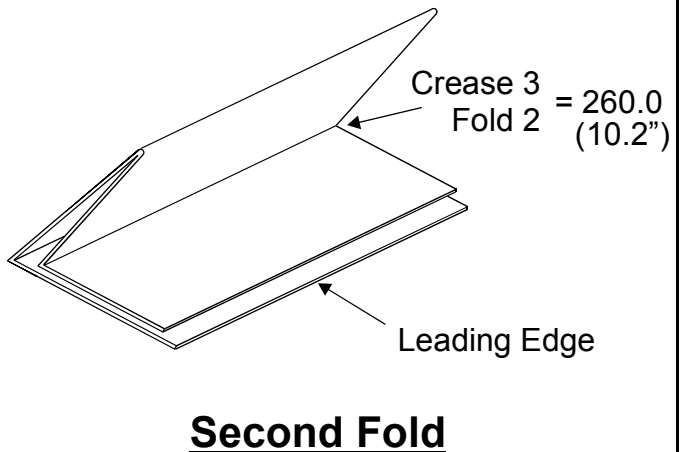
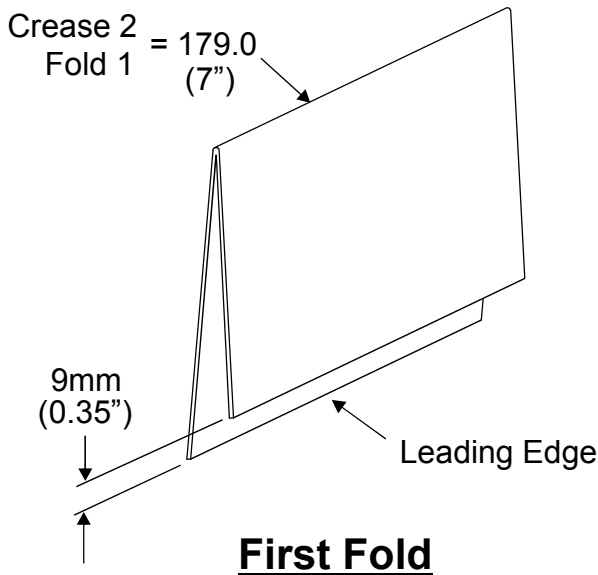

Operating the Atlas C300

Delivery Settings Page.

To get to the Delivery setting page click the lower



Roller position may be micro adjusted by clicking here.

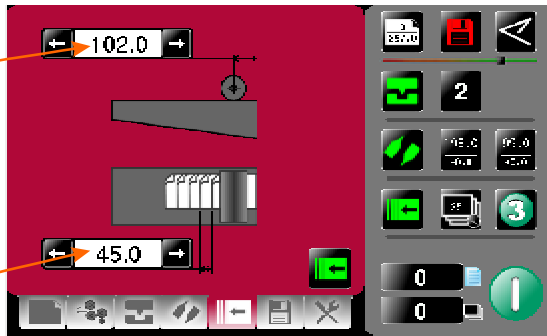

Shingle may be micro adjusted by clicking here.

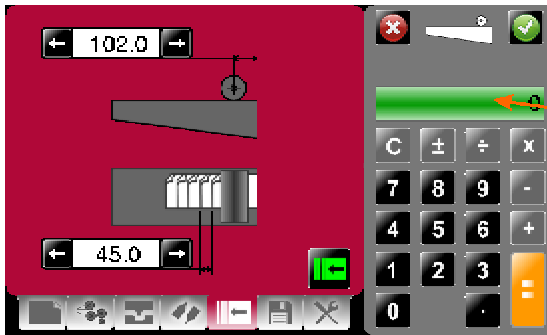

Roller adjustment calculator.

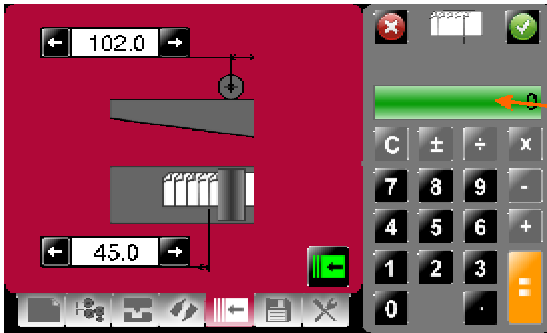

Shingle adjustment calculator.

The Delivery can be toggled On or Off by clicking here.

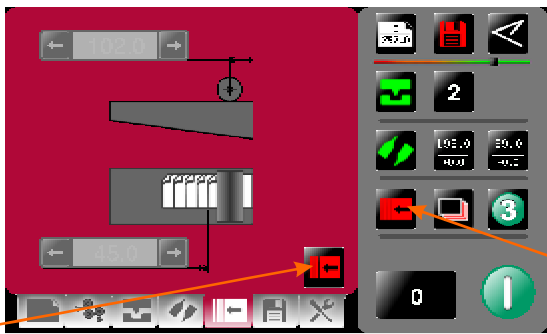

Delivery on/off status red is off green is on.

Setting the Delivery Conveyor System.

WARNINGS:-

1. The Machine will not start if the delivery unit is not in its up position.
2. If the delivery is turned off the roller will feed to the far end of the belt conveyor and park there until turned on again.
3. If the delivery is turned on when using the 'Set by Fold' mode of operation; the Roller Position and Shingle Length are automatically set, relative to the paper length and type of fold selected.
4. When using the 'Set by Position' mode of operation; the Roller Position and Shingle Length must be adjusted manually to suit the job. (See FIG 17.1 below).
5. When the optimum settings for the roller position and shingle length are achieved they can be stored with the job.

NOTE.

When setting the machine to do a Double Fold or Engineering Fold, with a paper length of 279mm (11") or less, the stacker roller will travel to the far end of the conveyor and stop. This is due to the shortness of the folded paper exiting from the machine.

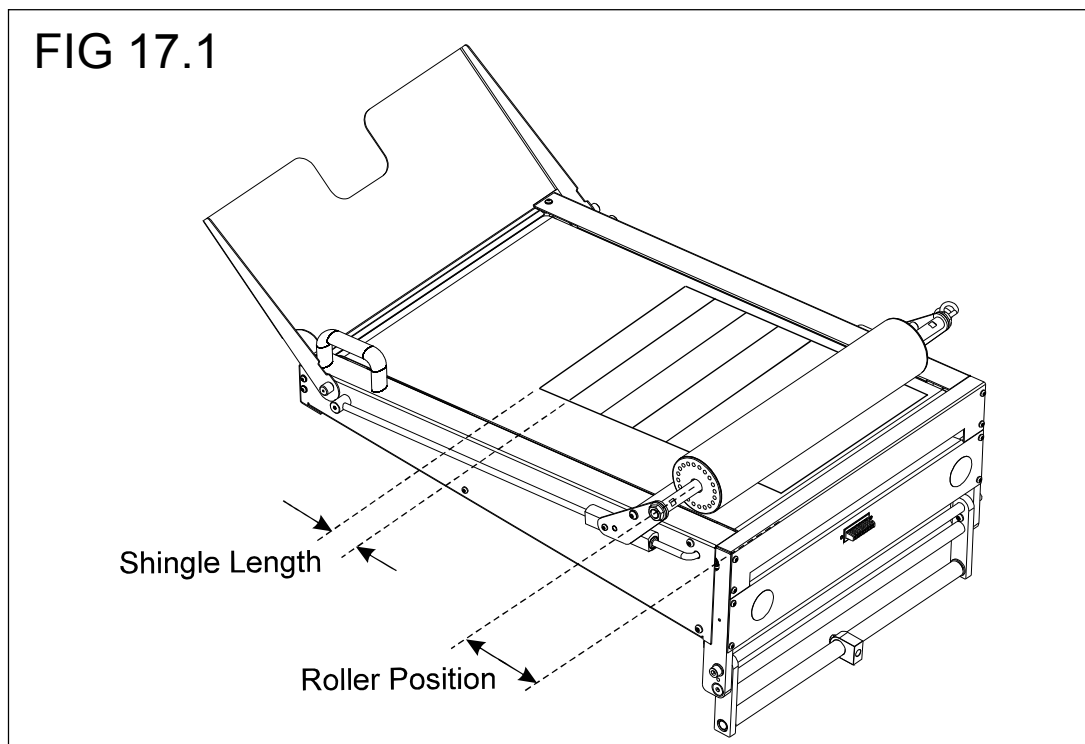

Operating the Atlas C300

Status Screen.

Green icon indicates settings are saved - a red icon would show that settings have changed but the job has not been saved.

Clicking in this area will take you to the store page

Clicking in this area will take you to the paper setting page.

Paper length & Paper Type - input from the paper setting screen.

Lead Edge Sensor Strength, Indicator Bar

Number of creases - this may alter automatically if a pre-defined fold is selected. Adjustments may be made in the crease setting screen.

Indicator for status of knives.

-  K1 & K2 On.
-  K1 Off & K2 On
-  K1 On & K2 Off
-  K1 & K2 Off

Currently selected fold type - can be one of the following.



Clicking in this area will take you to the crease setting page.

Fold Positions & Trim settings

Clicking in this area will take you to the Fold setting page.

Select this button to produce 3 test sheets with the settings currently shown.

Batch quantity - this is input from the batch calculator on the paper setting screen - max. 999

Clicking in this area will take you to the delivery setting page.

Sheet count -click to zero A screen will appear to confirm that you want to reset the count.

Batch count - click to zero A screen will appear to confirm that you want to reset the count.

Click to start machine with settings currently shown - you will receive a notification if system switch is not on. Press again to stop Job



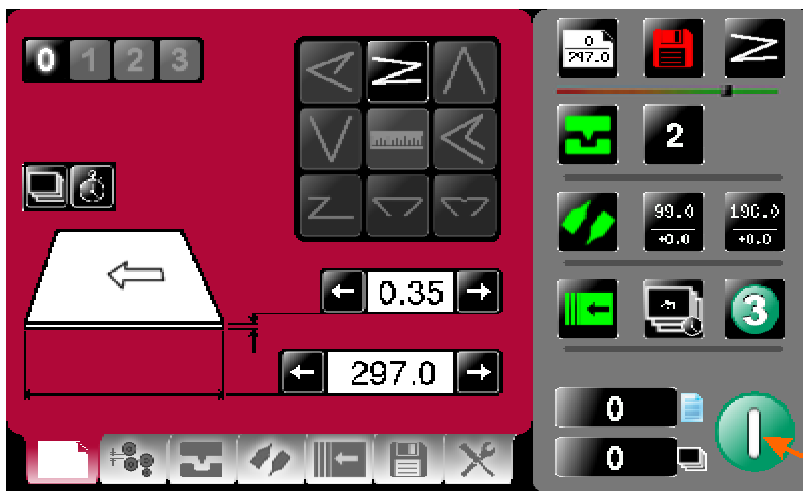

Operating the Atlas C300

Run Job.

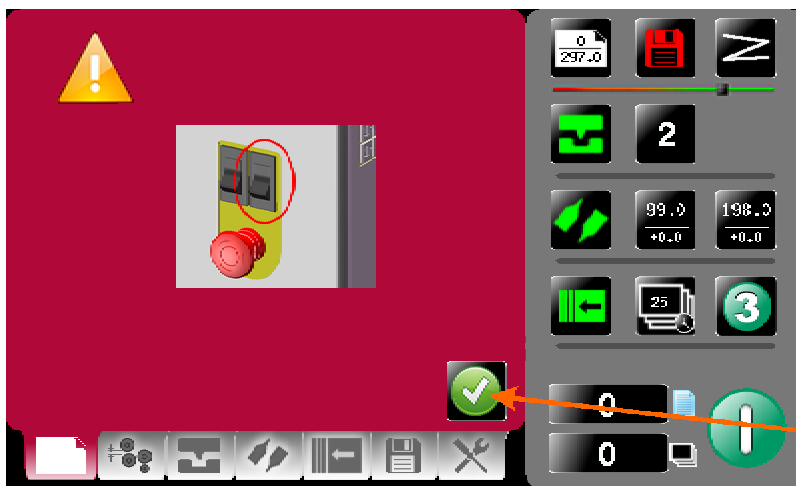

Click to run machine.

System Switch Not On.



Click to confirm System switch is on & then click run button again

The machine running screen will appear.

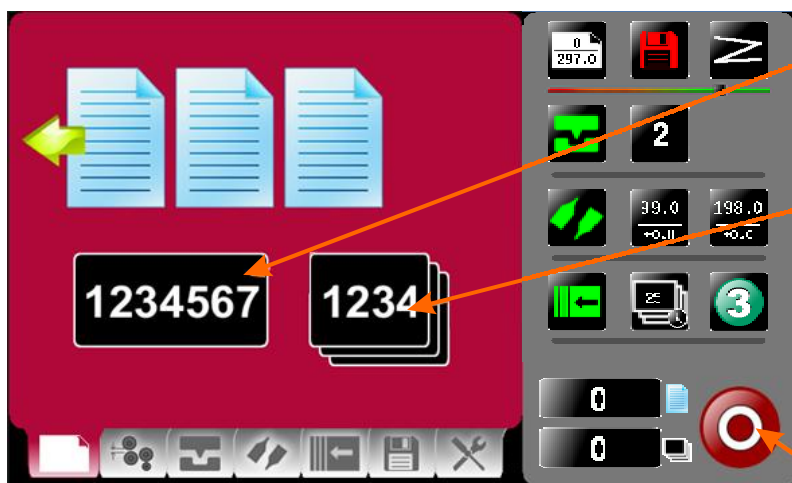

Run count

Batch Count

Job Count

Click to stop machine.

Setting the machine to operate in manual sheet feed mode

In order to feed heavy stock, very small or very large sheets, embossed or even irregular shaped sheets, it may be necessary to feed the sheets manually.

The machine can be programmed and set up in exactly the same way as explained when operating the machine automatically. However, the paper gate must be raised to its highest position for the sheets to be fed freely.

The machine can now be started by activating the System switch to 'on'. **Do not activate the Compressor switch.**

Select the  icon on the touch screen and begin to slide the sheets individually through the paper gate until they are driven by the drive belts.

To stop feeding the sheets, select the  icon on the touch screen and switch the System Switch off.

NOTE.

If the delay between feeding sheets is excessive, the system will time out.

Operating the Atlas C300

Store Pages.

To get to the Store setting page click the lower tab



or



from the status area.

New Jobs.

Having set up your job you can give the job a name and save it to a store. You can also retrieve previously saved jobs, modify them or delete jobs you no longer require.

To create a new job name click in text area & keyboard will open to input job name.

Load existing job from store



Clicking to search currently stored jobs

Clicking to delete currently stored jobs

Current Job Name
Yellow Text Denotes Saved Job
Red Text Denotes Unsaved Job

Clicking to save job shown.

Keyboard for entering job name.

Delete all characters

Delete last character



Return to Store Menu & click save icon  to save job to store

Operating the Atlas C300

Save confirmation screen.



To confirm saving of job click here.

Search for current jobs to load or modify.

You can search for jobs by clicking the search icon , this will bring up the search keyboard for text input.

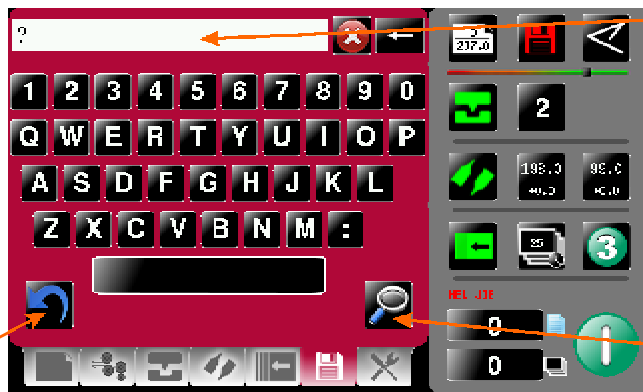

Type in job description or first few characters

Press search icon to start search

To change your mind & return to the previous screen click here.

Jobs matching characters in text box will be shown in this area - selecting job from this area will show job settings in the right hand status area. Job selected will be shown in text box.

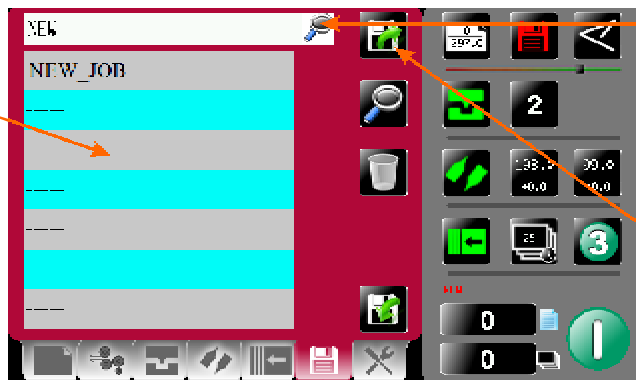

Toggle between search results & full list of jobs

Press to load job shown in text box.

Operating the Atlas C300

Loading job confirmation screen.

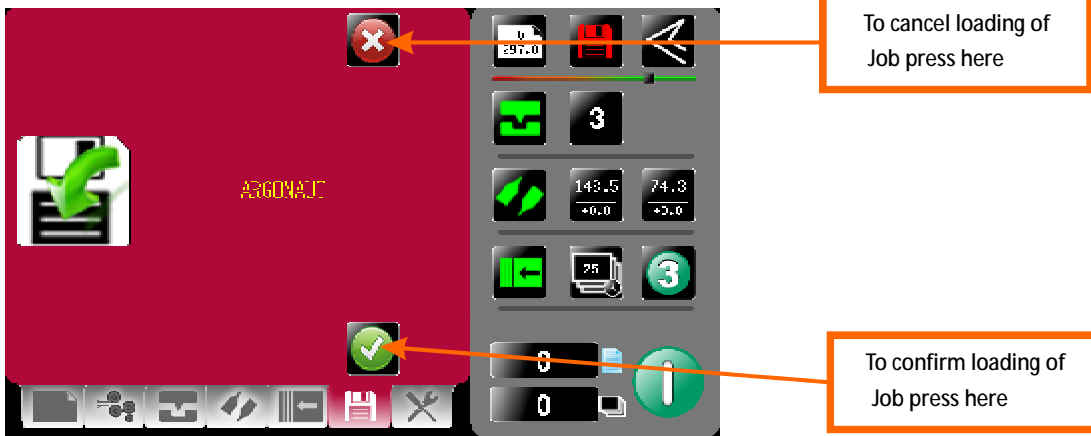

Loaded job may be modified and then re-saved as the same job name.

Overwrite job confirmation screen.

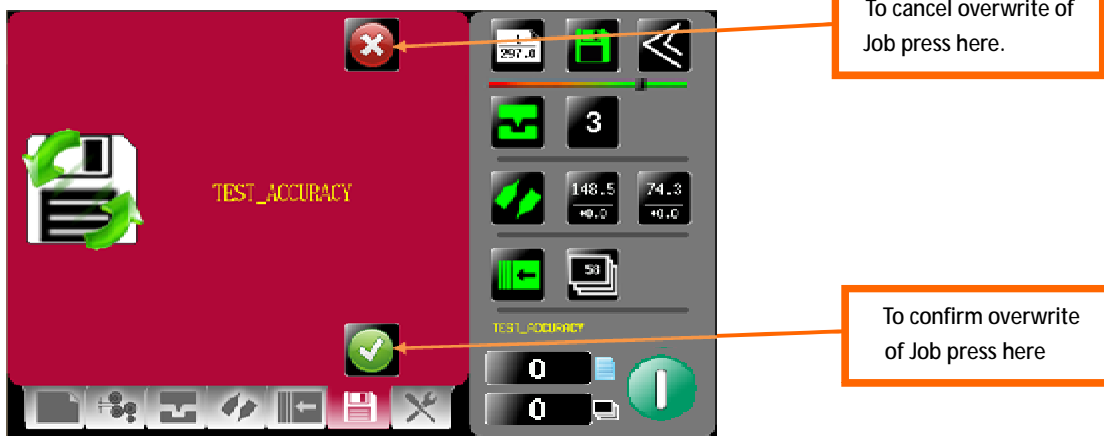

Delete job confirmation screen.

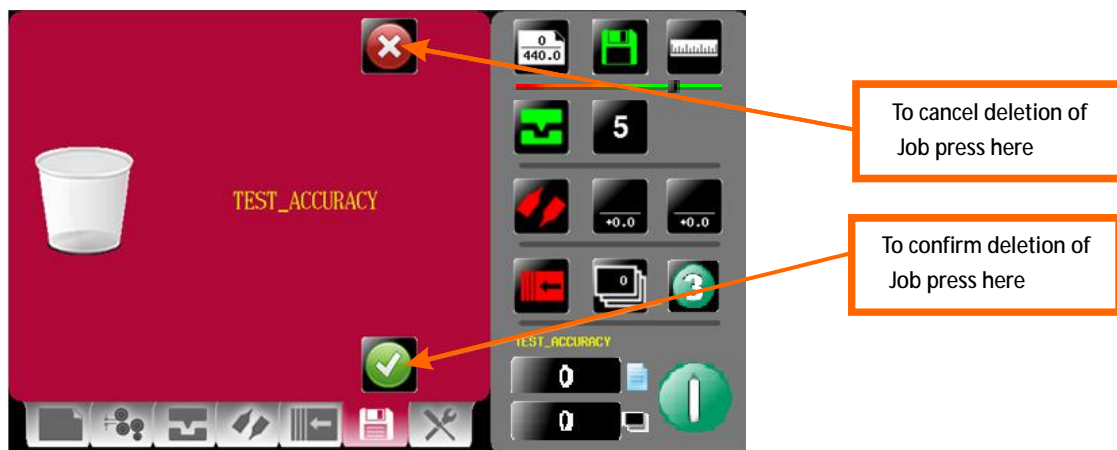

Operating the Atlas C300

Tools Menu.

To get to the Tools page click the lower tab



Inch paper in direction of arrow to clear jams

Clean Lead Edge Sensor

Touch Screen Calibration See Page 36

Change Machine measurement settings, Imperial / Metric

Toggle K2 ON and OFF Used to Set Deflect Trims See Page 37

Clicking this icon will show Machine programme revision & Touch Screen software revision.

Click on Up Arrow to put Anvil into Top Dead Centre position (TDC)

Inch paper in direction of arrow to clear jams

Touch screen software revision

Machine main board software revision

Touch Screen Calibration.

1. Switch the mains power on and wait for the main screen to appear before commencing to check the horizontal and vertical position of the display. The position of the display within the surround is achieved by operating the button at the rear of the housing, press this a number of times to obtain the correct orientation required, move to the next button to move the position to centralize horizontal.

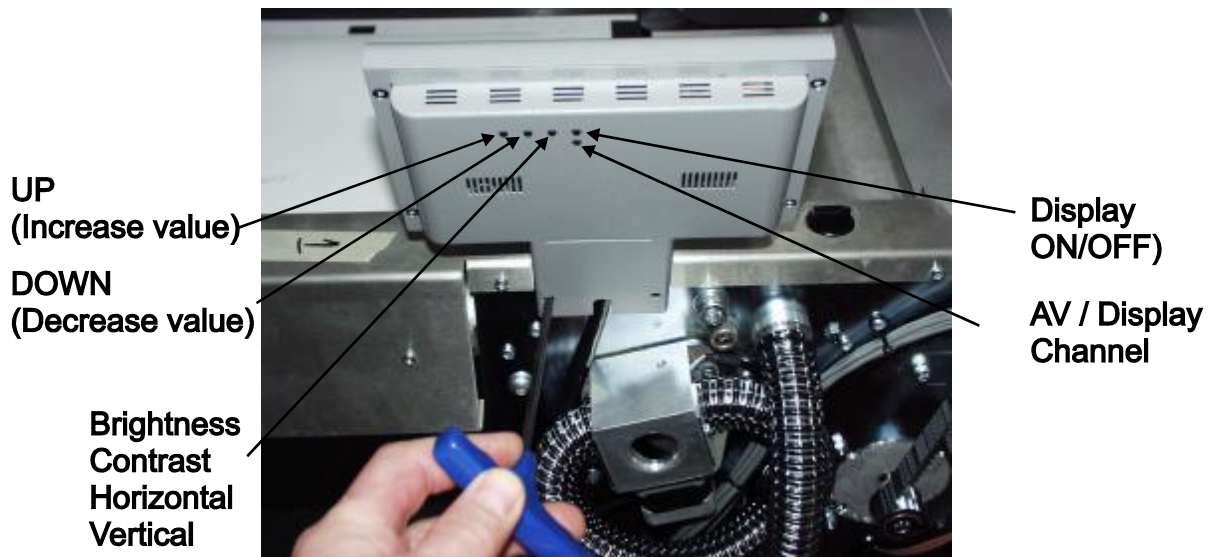

2. (i) Select the tools menu tab, and then Select the Touch Screen calibration icon.



- (ii) Using a plastic pointer, soft leaded pencil, biro cap etc. and with gentle pressure. Touch the centre of the cross in each corner of the Touch Screen, as prompted, by the hand graphics. This procedure will calibrate the Touch Screen.

Deflect Trim Adjustments

The deflect trims may need to be calibrated to allow the sheet to pass through the machine without damaging the lead edge.

1. K1 Double Deflect Trim
In the tools menu



Conduct this test with K2  turned off using the 'Tools' menu. 

If marking occurs on K1 then follow these general rules.

- Roller marks are caused by the Fold knife being too late, and so minus some K1 Deflect trim.
- General scuffing of the sheet underside are caused by the fold knife being too early, add some K1 deflect trim.

2. K2 Double Deflect Trim



Ensure K2 is turned on using the 'Tools' menu. 

If marking occurs when K2 is turned on then follow these general rules.

- Roller marks are caused by the Fold knife being too late, and so minus some K2 deflect trim.
- General scuffing of the sheet upper side are caused by the fold knife being too early, Add some K2 deflect trim.

The Blade Assembly

Adjusting the blade pressure (no paper required)

- (i) Switch the power 'on' by turning the Emergency stop button clockwise to release the safety latch.
- (ii) Select the Tools tab  at the bottom of the touch screen, the display will change to that shown below.
- (iii) Activate the system switch to 'ON'
- (iv) Select the up arrow to move the blade to the Top Dead Centre position.

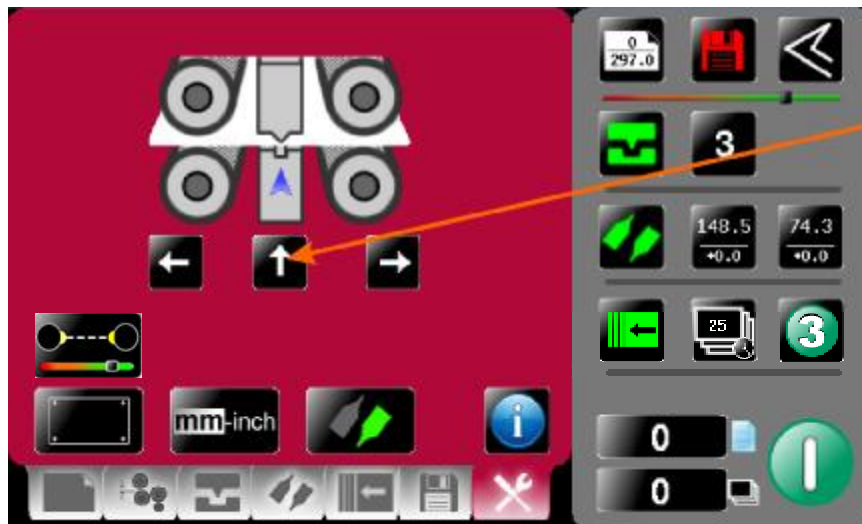

Click on Up Arrow to put Anvil into Top Dead Centre position (TDC)

2. Raise the exit guard
3. Using a 5mm allen key, unlock the socket head screws positioned at each end of the creasing blade.
4. Rotate the blade adjustment cams until they are just tight, and then back off slightly before tightening the socket head screws.

The diagram below demonstrates the adjustment of the blade pressure

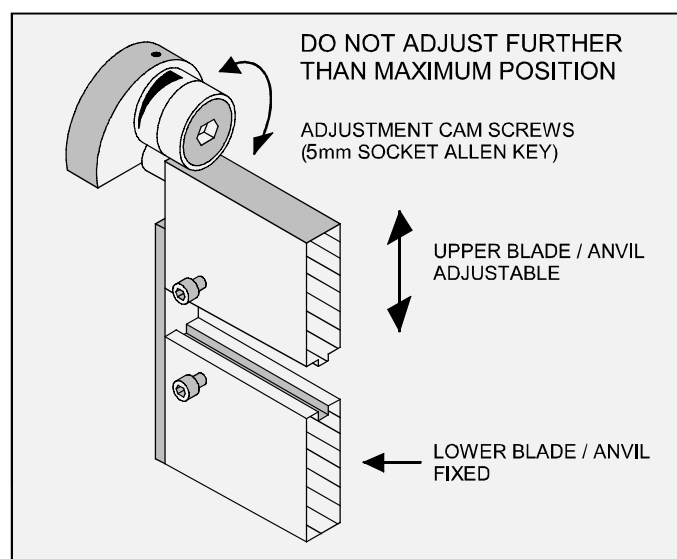

Replacing Blade Sets

1. Before removing the blade assembly, ensure that the lower blade / anvil is at 'Top Dead Centre', see page 38.
2. Lift the top cover.
3. Using a 5mm allen key, remove the two socket head screws, one each end of the Blade Set, as shown in FIG 32.1 below.



FIG 32.1

4. Remove the Sheet Guide Assembly, by pulling upwards on the two flanges, one each end, as shown in FIG 32.2 and FIG 32.3 below.

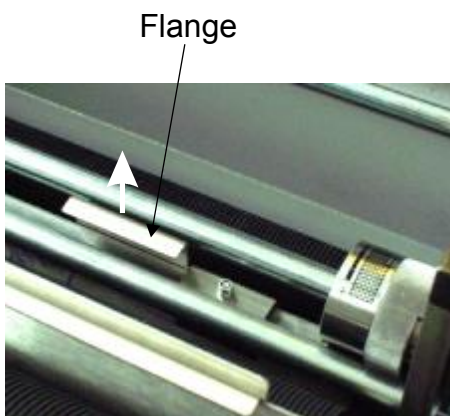

FIG 32.2

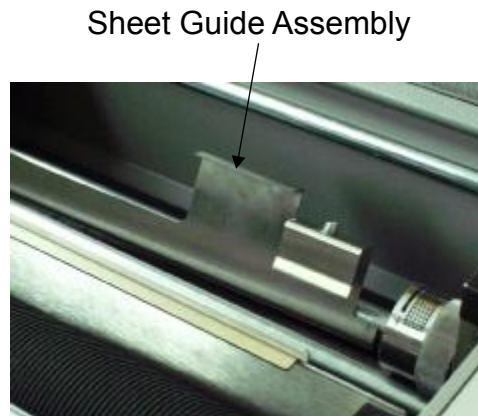

FIG 32.3

5. The Blade Set can now be removed from the machine using the Blade Extractor Tools shown in FIG 32.4 below.



Blade Extractor Tools

FIG 32.4

Replacing Blade Sets

6. Insert the Blade Extractor Tools, one at each end of the Blade Set, as shown in FIG 33.1 below.



Note The Position of The Blade Extractor Tool Under The Lip of The Blade Adjuster Assembly

FIG 33.1

7. Lever the Blade Assembly in the direction shown in FIG 33.2 to unclip and release the Blade Set.

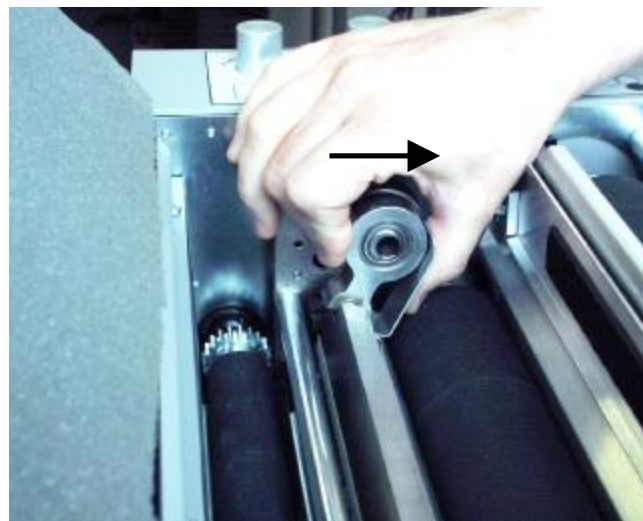
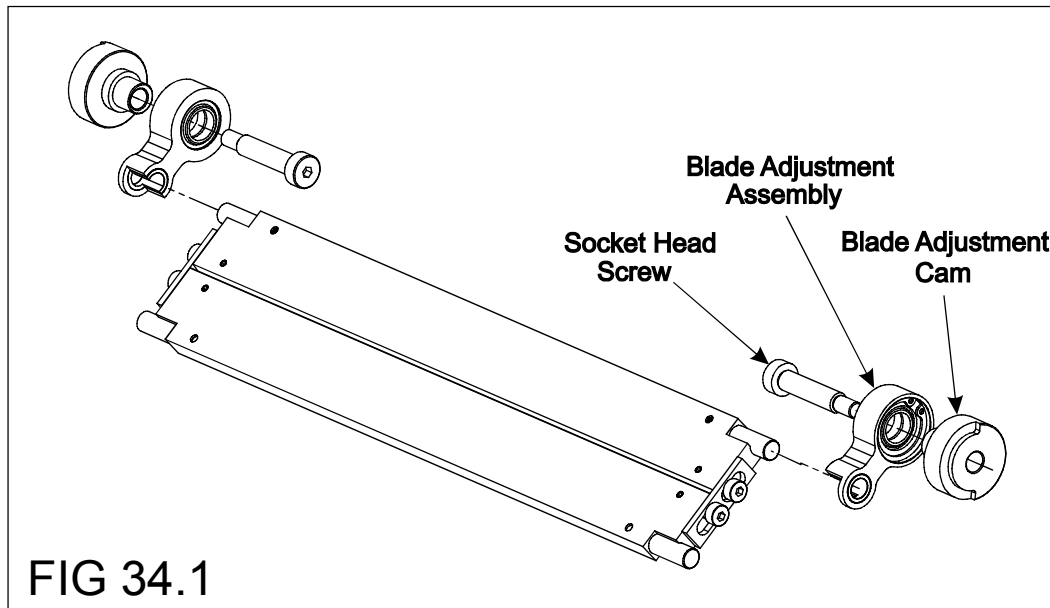

FIG 33.2

Replacing Blade Sets

- Slide the blade assembly out of the creasing unit and lay it on a flat surface.
- Slide the blade adjustment cams and the blade adjustment assemblies away from the dowels located in the ends of the blades / anvils as shown in FIG 34.1 below.



- Slide the blade adjustment assemblies and the blade adjustment cams onto the dowels of the new blade set.
- Slide the new blade set into the slots of the creasing unit as shown in FIG. 34.3.

NOTE.

The blade set can be fitted with the ANVIL at the bottom or with the ANVIL at the top. The blade set is supplied from the factory with the ANVIL at the bottom as shown in FIG34.2A.

The blade set can be changed to have the ANVIL at the top (as shown in FIG34.2B), this can improve the repeatability of the fold relative to the crease for certain fold types or when using lighter stocks.

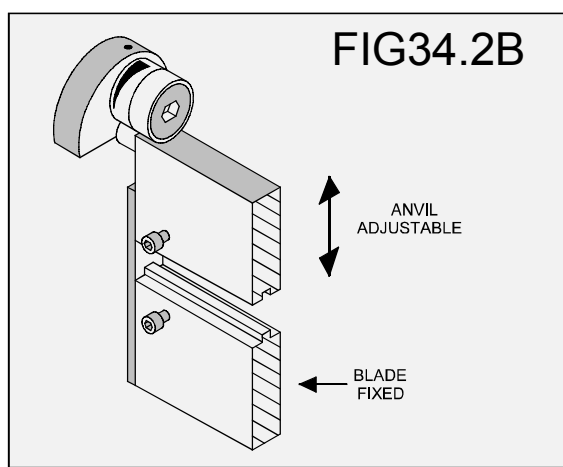
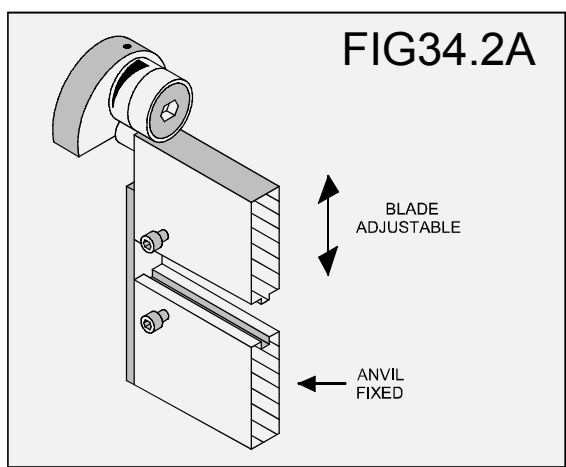

Perforating

Once the machine is set-up, the Machine can be used to perforate or crease.

Notes

1. Perforating and creasing can be carried out simultaneously. However, if any adjustment is made to the roller tilt mechanism in order to compensate for the perforation line being 'out of square', this may effect the accuracy of the crease. If this occurs creasing and perforating must be carried out as separate operations.
2. By adjusting the outfeed drive tyres relative to the drive hubs it is possible to steer the sheet, (i.e. By placing the tyre on top of the hub one side of the paper will steer faster on that side).

The components and tools required to install the perforator are contained in the despatch kit supplied with the machine, they are listed below.

- 1 off Set of standard perforation '28 tooth' blades.
- 1 off Set of standard hardened anvils.
- 1 off 3mm bondhus wrench / allen key
- 1 off 2mm bondhus wrench / allen key



The perforator blades are split into two matching halves and are fitted to the drive wheels as shown in the photograph using the four screws supplied.

A hardened anvil is fitted to the drive hub as shown in the photograph also using the four screws supplied. Again the anvils are made from matching halves.

Important: The perforator blades are very sharp and care must be taken whilst handling. Do not mix the matching pairs of blades or anvils.

Perforating 'Spares' kits

For perforating and other types of paper, various spares kits are available which can be assembled to the machine in the same fashion. They are listed below along with a range of scoring wheels,

Perforating blades	56 teeth	Part Number	1-99-41	- Standard stock / fine perforations.
	28 teeth	Part Number	1-99-12	- Medium stock / Medium perforations.
	20 teeth	Part Number	1-99-10	- Heavy stock / coarse perforations.
Anvils		Standard Part Number	1-99-35	- For all blade types

All of the blades and anvils are supplied with fixings.

***Perforator stripper** Standard Part Number **177-05-01**

*It is recommended that for multiple perforations, a separate perforator stripper is used for every perforating blade set fitted in the creasing unit.

Setting the machine

1. Turn the mains supply to the machine 'off'.
2. Open the perforator assembly to get access to the drive wheels and hubs.
3. Locate and remove the blades / anvils from the despatch kit supplied with the machine.
4. Using the 2mm allen key (supplied), loosen the drive wheel that is to accommodate the blades.
5. Slide the drive wheel away from any obstructing drive wheels or hubs in order to mount the blades.

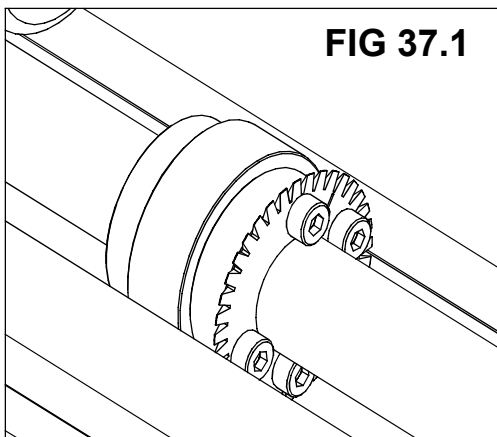

6. Using the 2.5mm allen key (supplied), take one half of the matching pair of blades and mount on to the drive wheel. Do not secure the blade.
7. Mount the other half of the blade to the drive wheel as shown (FIG 37.1). Secure the blades to the wheel ensuring not to over tighten grub screw.
8. Mark on a single sheet the desired perforating position. Feed the sheet through the machine manually until the mark can be seen. Use this mark to assist in fixing the position of the perforating drive wheel to the roller drive shaft.

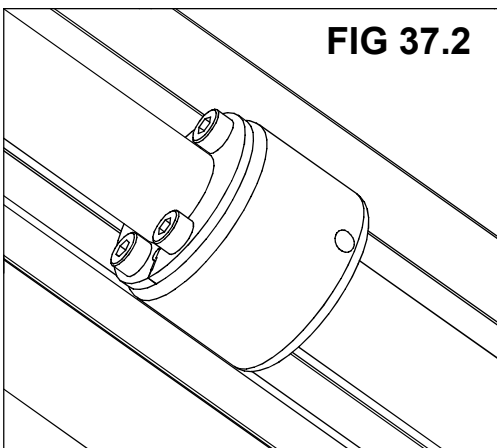

9. Using the 2mm allen key, loosen the drive hub nearest the perforating drive. Slide the drive hub away from any obstructing drive wheels or hubs in order to mount the anvils.
10. Using the 2.5mm allen key, take one half of the matching pair of anvils and mount to the drive hub. Do not secure the anvil.
11. Mount the other half of the anvil to the drive hub as shown (FIG 37.2). Secure the anvils to the drive hub ensuring not to over tighten the grub screws.

Perforating

12. Slide the drive hub towards the perforating drive wheel until there is a clearance of 0.5mm (0.020").
13. To prevent damage to the blades or the anvils, do not force the drive wheel against the hub.
14. Fix the perforator stripper adjacent to the drive wheel and blade as shown.
15. Operate the machine and test the perforations for form.

It is important that the drive hubs are arranged evenly across the width of the paper in order to reduce the risk of jamming.

For multiple perforations repeat the above procedure.

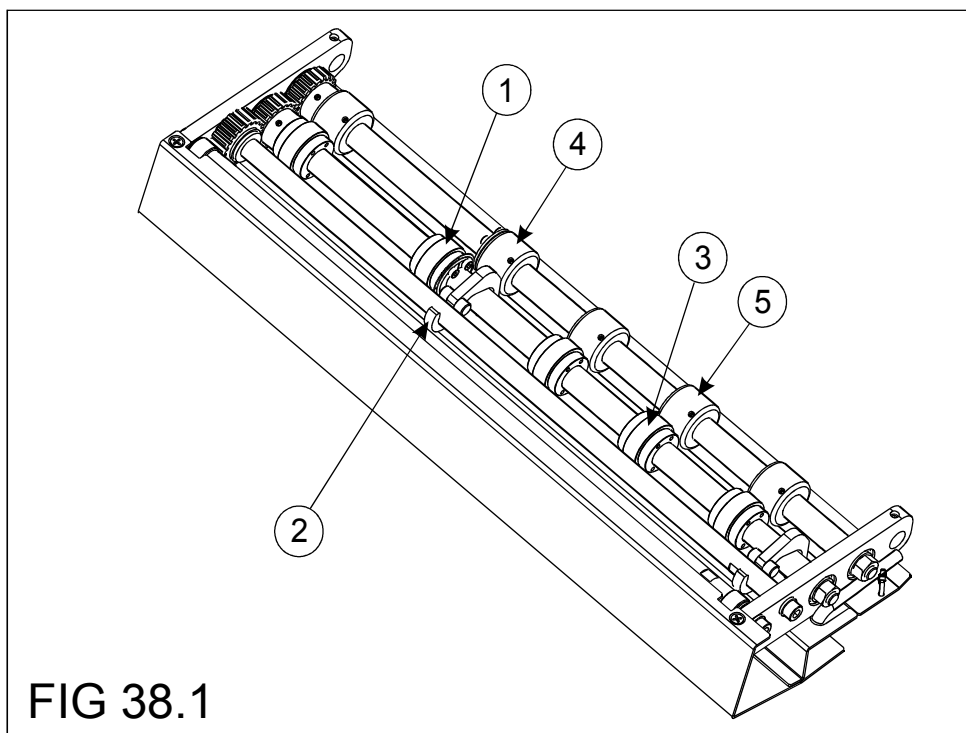

FIG 38.1

Fig 38.1 Demonstrates a typical set-up for perforating sheets.

- | | |
|---|-----------------------------------|
| 1 - Perforating drive wheel with mounted blades | 4 - Drive hub with mounted anvils |
| 2 - Perforator stripper | 5 - Standard drive hub |
| 3 - Standard drive wheel | |

Always remove blades and anvils once the perforating operation has been completed to avoid marking on digital or delicate media.

Removing Paper Jams

Removing Paper Jams

In the event of a paper jam occurring, whilst running the machine, follow the steps described below to allow access to remove the jammed paper.

1. Unlock and lower the delivery unit, open the top cover and the perforator unit; see FIG 39.1 below.
2. If the paper is jammed in the fold rollers; try to rotate the top fold roller, using both hands. Position the thumbs under the tie bar and spread the fingers out above the tie bar.

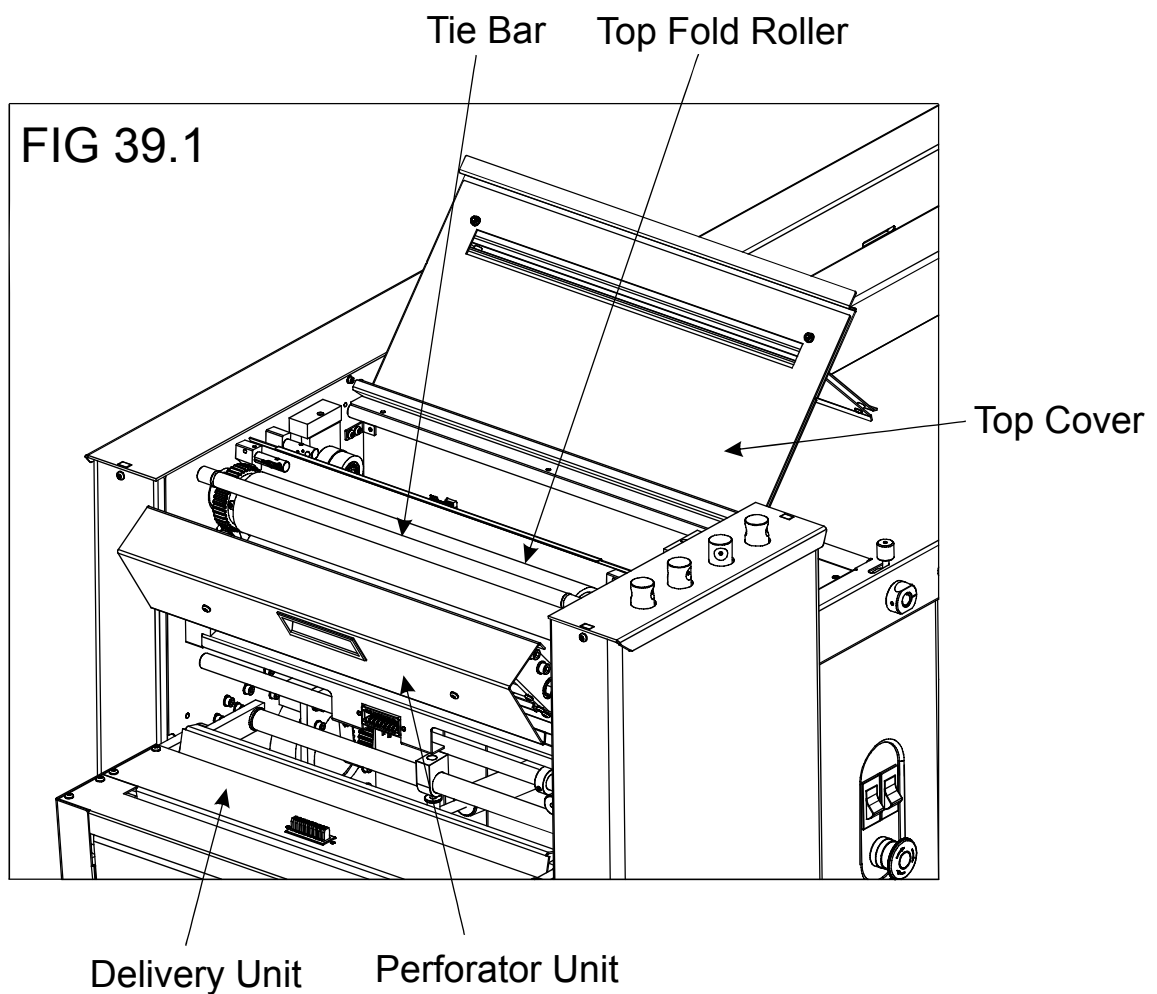

Trouble Shooting

Paper crease out of square

- Check that the sheets are all square and exactly the same size before loading the stack on to the table.
- Check that the adjustable side lay has been correctly positioned ie. No further than 0.5mm (0.020") from the paper stack.
- Check that the blade tilt mechanism is correctly set.

Crease Position Inaccuracy

- Check that the crease profile has not been set too deep.
- Check that the correct Blade Set is fitted. (Standard Blade Set for material thickness of 0.25mm (0.010") and above, Narrow Blade Set for material thickness of 0.25mm (0.010") and below).

Paper fold out of square

Note:- the best fold squareness may be achieved when the fold is not on the center of the crease, but to one side or the other. Try this first.

- Check that the fold is to one side of the crease center line.
- Check that the roller gaps are not too tight and squashing the crease.
- Check that the roller gaps are not too large and allowing the paper to slide (especially so on glossy paper).

Paper jamming

- Check that the leading edge of the paper is not being damaged by the paper gate. If this is occurring, check that the suction slot and the paper gate have been correctly set.
- Check that the first crease / fold position is not too close to the leading edge of the paper. A minimum distance of 50mm (1.96") is recommended.
- If jamming is occurring in the Perforator - adjust the Hubs (see Pages 12 & 45).

Machine will not start

- Check the power supply to the machine.
- Check that the emergency stop button has been released.
- Check that the top cover is down.
- Check that the perforator assembly is in its closed position.
- Check that the delivery unit is in the up position, and located correctly, (the machine will not start if the delivery unit is not in its up position).

Paper not feeding

- Check that the paper stack is not too high or too heavy for the feeder. The height of the paper stack should be defined by the weight and the size of the stock being creased.
- Ensure that the adjustable side lay is not pressed against the paper stack. However, if the clearance between the adjustable side lay and the paper stack is too great, the air supply will escape instead of blowing through the paper thus making it difficult to feed.
- Check that the clearance between the paper gate and the suction roller is not set too low.
- On digital media, the feeding performance may be improved if the leading edge of the stack is trimmed before loading onto the Digifold.
- Check that the air distribution has been correctly set.
- Check that the air separation has been set high enough to feed the sheets.
- For heavy stocks, very small or very large sheets, embossed or even irregular stock, it may be necessary to feed the sheets manually - see page 31.

Cracking of the Printed Material along the Crease.

Cracking of the material along the crease may be caused by the following:-

- Pressure too heavy on the top blade - reduce pressure.
- Cracking on one edge caused by misalignment of the anvil and blade.
- **When using dry ink or toner based print engines, the material must be fully acclimatised for at least 48 hours before putting an image onto the paper.**

Using the Correct Blade Set.

- Two Blade sets are supplied with the machine.
The Standard Blade set is suitable for material thicknesses of 0.25mm (0.010") and greater.
The Narrow Blade set is suitable for material thicknesses of 0.25mm (0.010") and smaller.
- If the Standard Blade Set is used to crease and fold materials less than 0.25mm (0.010") inaccurate results can be produced.
- If the Narrow Blade Set is used to crease and fold materials greater than 0.25mm (0.010") cracking can occur. More importantly this could cause the main motor to temporarily stall. This probably won't be that noticeable until you look at the results, whereby the crease position will vary.

Error Screens

- **Sheet did not arrive.**

If the machine stops and error message 01 is displayed on the touch screen, this indicates that the paper did not arrive at the end of the suck process; so the machine timed out. Press the green tick button and then press the start button.



- **Paper Crunch**

If the machine stops and error message 02 is displayed on the touch screen, this indicates that a paper jam has been detected.

Press the system switch down and then select the right or left arrows, to inch the paper forwards or backwards. See page 39 that describes how to remove paper jams. Press the green tick button and then press the start button.



- **Double Sheet Feed**

If the machine stops and error message 03 is displayed on the touch screen, this indicates that a double sheet feed has been detected. Check that the paper gate has been set correctly. Press the green tick button and then press the start button.



- **Blade Not Home**

If the machine stops and error message 04 is displayed on the touch screen, this indicates that the lower blade / anvil has not made contact with the HOME switch. i.e. blade still in top position. Switch the machine off and remove the blade set and ensure that the area is free from obstructions. Return the blade set to the creasing unit and switch the machine on. Operate the machine in the normal sequence, if the display continues to read error message 04 it is advised to contact a Service Engineer immediately.

Error Screens (Continued)

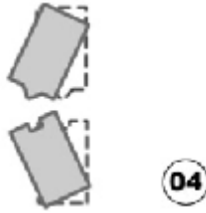

- **Blade Busy**

If the machine stops and error message 05 is displayed on the touch screen, this indicates that the blade is busy. Try to operate the machine again, If this fails it is advised to contact a Service Engineer.

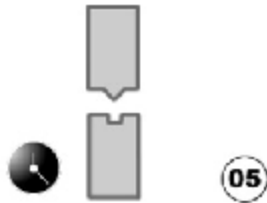

- **Blade Home Failure 1**

If the machine stops and error message 06 is displayed on the touch screen, this indicates that there may be some creasing errors, and that the creasing pressure should be checked, (also check for a double that may have got through, causing this error).

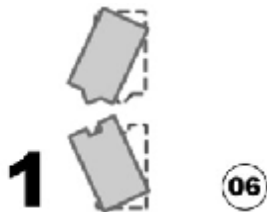

- **Blade Home Failure 2**

If the machine stops and error message 07 is displayed on the touch screen, this indicates that the crease blade did not get back to its home position correctly or at the correct time. Causes, can be excessive blade pressure (suspect a double), or Some kind of jam which caused more than one sheet thickness to be creased.



Error Screens (Continued)

- **Flying Home Failure**

If the machine stops and error message 08 is displayed on the touch screen, this indicates that the home signal was missed during creasing. Check that the blade pressure is not too high.

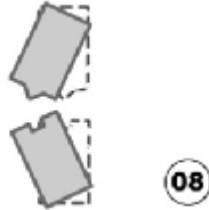

- **Clip 1 NOT clear (Back Sensor)**

If the machine stops and error message 09 is displayed on the touch screen, this indicates that the sensor is or was blocked when it should have been clear. i.e. A jam in the paper path or the wrong length of paper has passed through the sensor.

To correct - check if paper is present and check that the paper path is clear before restarting. See page 46 that describes how to remove paper jams.

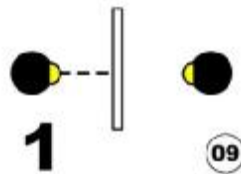

- **Clip 1 NOT Blocked (Back Sensor)**

If the machine stops and error message 10 is displayed on the touch screen, this indicates that the sensor did not see the paper at the correct time.

i.e. A jam in the paper path.

To correct - Check if paper has jammed in the machine prior to the sensor. See page 46 that describes how to remove paper jams.

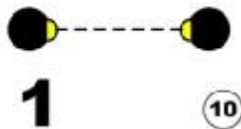

- **Clip 2 NOT clear (Top Sensor)**

If the machine stops and error message 11 is displayed on the touch screen, this indicates that the sensor is or was blocked when it should have been clear.

i.e. A jam in the paper path or the wrong length of paper has passed through the sensor.

To correct - check if paper is present and check that the paper path is clear before restarting. See page 46 that describes how to remove paper jams.

Error Screens (Continued)

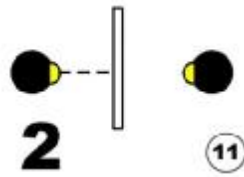

- **Clip 2 NOT Blocked (Top Sensor)**

If the machine stops and error message 12 is displayed on the touch screen, this indicates that the sensor did not see the paper at the correct time.

i.e. A jam in the paper path.

To correct - Check if paper has jammed in the machine prior to the sensor.

See page 46 that describes how to remove paper jams.

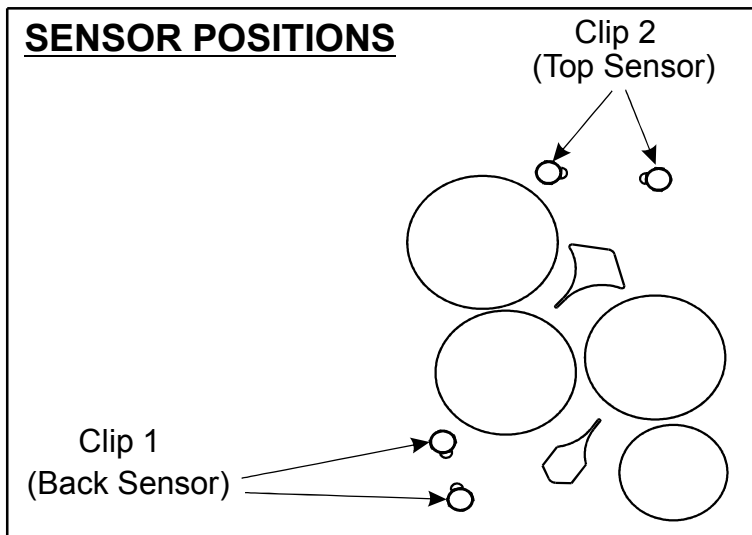
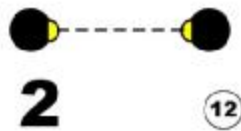

- **Overlap**

If the machine stops and error message 13 is displayed on the touch screen, this indicates that the 'Lead Edge Sensor' has seen a sheet subsequent to the first one as being longer. Again this could actually be a longer sheet, OR it could be a sensor problem (if it is a recurring problem). Check that the paper gate has been set correctly.



Error Screens (Continued).

- **Lead Edge Sensor Fault**

If the machine stops and error message 60 is displayed on the touch screen, this indicates that the lead edge sensor is blocked.

Press the system switch down and then select the right or left arrows, to inch the paper forwards or backwards.

Press the green tick button and then press the start button.

This error message could also mean that the lead edge sensors are faulty or need cleaning.

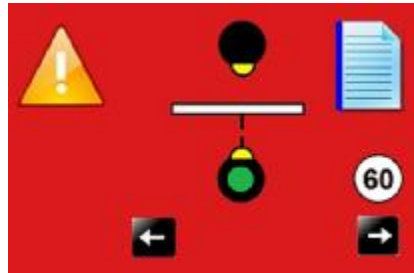

Error Screens (Continued)

● Clean Lead Edge Sensor - Warning Screens.

1. The Clean Lead Edge Sensor warning screen, shown below, will appear when the Run button is pressed and the strength of the Lead Edge Sensor Beam is at about 50% (i.e. the slider is at about the mid-point position along the Indicator Scale).

SENSOR CLEANING WARNING SCREEN

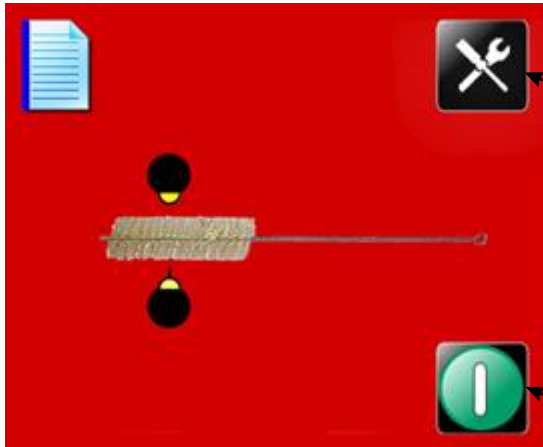

Press the Tools button to clean the Sensors, as described on Pages 56 & 57.

Press the Run button to ignore the Warning, and continue running the job.

2. The Clean Sensor, Error 65 warning screen, shown below, will appear if the strength of the Lead Edge Sensor Beam is allowed to get down to about 25%. The Lead Edge Sensors should ideally be cleaned before this warning screen appears.



NOTE.

The Lead Edge Sensors can be cleaned at any time by selecting the Tools Tab  at the bottom of the Touchscreen and cleaning the Sensors as described on Pages 56 & 57.

Error Screens (Continued)

Lead Edge Sensor Cleaning.

Select the Tools menu on the Touchscreen Display, and then select the clean sensor icon



The screen now shown is a visual indication of the strength of the Lead Edge Sensor beam.

FLASHING (GREEN/BLACK) TO INDICATE THAT THE SOFTWARE IS INTERROGATING THE SENSOR BEAM

SLIDER

INDICATOR SCALE

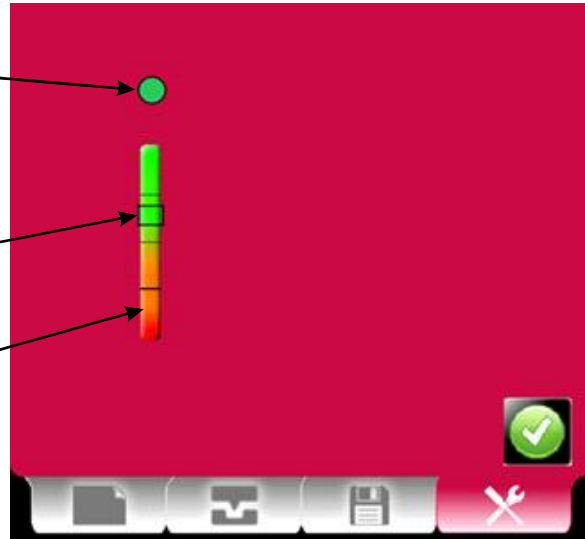

The vertical indicator scale is divided into four sections, the position of the slider indicates the strength of the beam. The strength of the beam is at its strongest towards the top half of the indicator scale (green) and at its weakest towards the bottom half of the indicator scale (red). Note the position of the slider on the indicator scale and then clean the sensors as described on Page 57.

NOTE:- This vertical indicator scale is repeated as a horizontal indicator scale on the right hand side of the Touchscreen Display as shown below.

HORIZONTAL INDICATOR SCALE

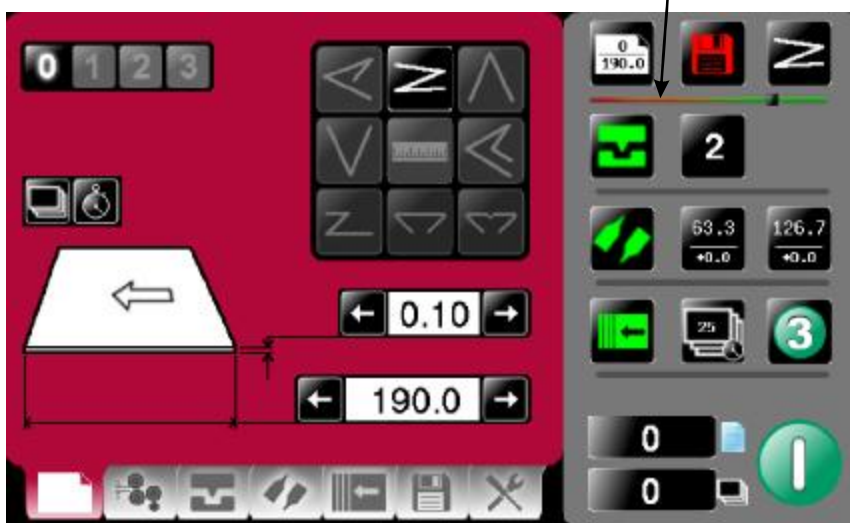

Error Screens (Continued)

To clean the lead edge sensors open the top cover unit to expose the blade set. Using the Sensor Cleaning Brush (part number 601-185), slid the brush under the ball holder and push it through to reach the upper and lower lead edge sensors. (See FIG.3 and FIG.4 below). Move the brush backwards and forwards several times across the sensors to clean them. Note the position of the slider on the indicator scale; the slider should have moved nearer to the top of the scale, indicating that dust has been removed from the sensors. This sensor cleaning operation can be repeated again to see if the sensor beam strength can be further improved. The Sensors can also be cleaned with a can of compressed air .

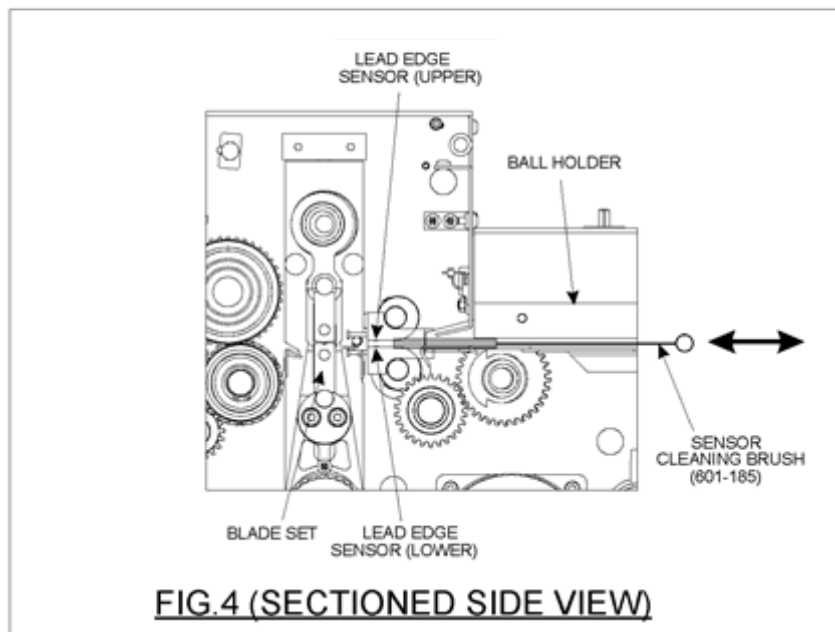
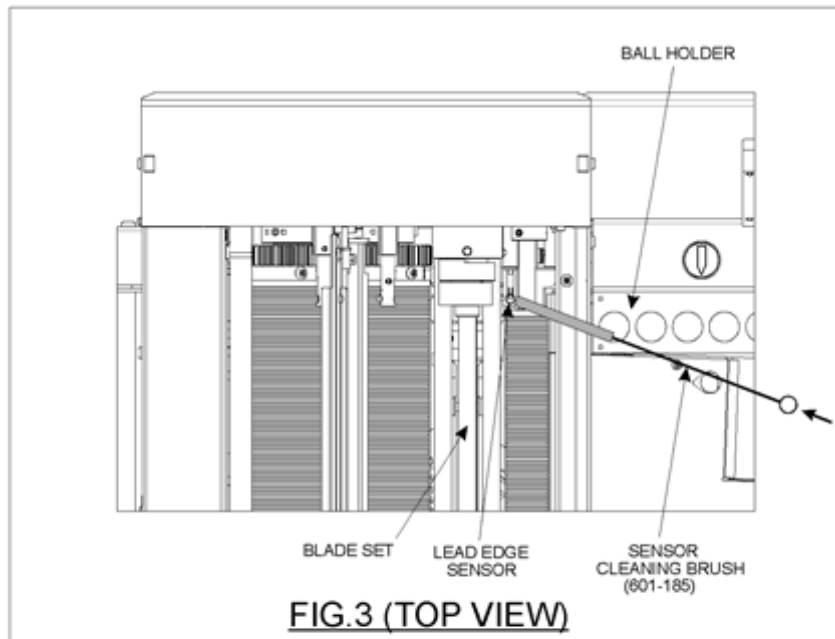

Trouble Shooting

Recommended weekly operator maintenance

Clean all sensors.

The lead edge sensor housing is located on the layedge side of the machine between the input roller shafts. With a slim brush the sensors can be cleaned when required. Pass the brush under the ball holder and push through until it passes the infeed rollers. Alternatively it can be blown with compressed air.

The Jam Sensor is situated just after the edge sensor and is inline across the paper path with the receiver in the operator side sideplate. This is not usually sensitive to dust but if required can be blown with compressed air.

Clip 1 sensor is situated on the lower guides beneath the delivery conveyor and can be cleaned when required using a slim brush.

Clip 2 sensor is situated on the upper guides inside the top cover and can be cleaned when required using a slim brush.

Clean in feed rollers and output drive hubs using the cleaning kit supplied (cleaning kit part number 90-018).

Remove and clean the blade assembly.

Technician Maintenance

It is recommended that your Machine is fully serviced at least once every six months by a factory trained Service Engineer.

BLANK
PAGE

DISPATCH KIT

ITEM	PART NUMBER	QTY	DESCRIPTION
1	174-036	1	OPERATORS MANUAL -
2	90-018	1	ROLLER CLEANING KIT
3	650-040	1	POWER CORD C19 UK 16A 2.5m
4	170-009-01	2	BLADE REMOVAL TOOL
5	601-167	1	DIGITAL THICKNESS GAUGE
6	403-01-030-006	12	SCREW - SOCKET CAP HEAD - M3 x 6 LG
7	409-01-040-004	1	SCREW - SKT. SET FLAT PT. - M4 x 4 LG
8	620-007	1	HEXAGON BALL DRIVER 2mm
9	620-020	1	HEXAGON BALL DRIVER 2.5mm
10	620-026	1	BONDUS L WRENCH 4mm
11	620-027	1	BONDUS L WRENCH 5mm
12	624-025	1	STATIONERY TUBE 330MM X 50MM
13	170-002-01	1	QUICK START CHART
14	624-018	1	DISPATCH BOX
15	1-99-35	1	SLITTING ANVIL SET
16	1-99-12	1	SLITTER PERF BLADE 28T
17	613-229	1	WRITE-ON SERIAL NO. LABEL
18	65-104	1	SPECIFICATION LABEL MSL/CE

ACCESSORIES AND OPTIONS

ITEM	PART NUMBER	DESCRIPTION
1	172-022-01	LOADING TABLE EXTENSION
2	AC-75	PERFORATING BLADE SET 20T (Card)
3	AC-76	PERFORATING BLADE SET 28T (Single Sheets)
4	AC-77	PERFORATING BLADE SET 56T (Fine Perfs)
5	AC-79	ANVIL SET USED WITH ABOVE BLADE SETS
6	AC-70	DOUBLE SHEET DETECTOR KIT
7	172-04-01	NARROW SHEET KIT
8	173-169-01	ETHERNET KIT
9	AC-60	DYNAMIC BLADE SET - ULTRA NARROW
10	178-01-02	STACKER ASSEMBLY -

ACCESSORIES....

....May be obtained from your dealer and fitted to your machine using the instructions supplied, or by reading your operators manual.

OPTIONS....

....May also be obtained and fitted by your dealer. You should not attempt to fit options as specialist tools and knowledge are required.

RECOMMENDED SPARES

PART NO.	DESCRIPTION
125-21-02	Dual Stepper Driver Board
125-25-01	Small Stepper Driver - High Power
174-06-01	Small Stepper Driver - Low Power
174-01-02	Controller PCB Assembly + Chip
174-19-01	RS232 Adaptor PCB Assy.
75-500-01	Mini ITX Motherboard -
126-059-02	Link - Paper Guide
128-026-03	Delivery Belt
145-093-02	Knife Driver Pin - M8
76-261	Lead - Delivery Input Connector
173-57-01	Lead - Blade Position Sensor
173-45-01	Lead - Tilt Pot
173-46-01	Lead - Gap Set 3 Pot
173-47-01	Lead - Gap Set 2 Pot
173-48-01	Lead - Gap Set 1 Pot
173-06-01	Power Supply - 48V
173-06-02	Power Supply - 24V
76-272	PSU Assembly - ATX12V - 300W
173-49-01	Stepper Motor - crease
76-240	Stepper Motor - Drive
76-257	Stepper Motor - Fold Knives
175-31-01	Input roller Assembly - Lower
175-31-04	Input Roller Assembly - Upper
175-042-01	Feed Belt
175-10-01	Edge Sensor Assembly
75-06-02	Touch Screen Assembly - 7" (New Controller)
175-11-01	Sensor Bar Assembly
175-11-02	Sensor Bar Assembly - Clip
175-11-03	Sensor Bar Assembly
175-12-01	1st Blade Assembly
175-12-02	2nd Blade Assembly
175-125-01	Connecting Link Assembly - Drive
175-125-02	Connecting Link Assembly - Knife Hubs
175-29-01	Fold Roller - 1st
175-29-02	Fold Roller - 2nd
175-29-03	Fold Roller - 3rd
175-29-04	Fold Roller - Fixed

RECOMMENDED SPARES

PART NO.	DESCRIPTION
172-05-01	Paper Gate Assembly
175-21-01	Vacuum Roller Assembly
176-02-01	Blade Adjuster Assembly
176-081-01	Worm Wheel - Gap Set
176-213-01	Dynamic Blade Set - Narrow
176-213-02	Dynamic Blade Set - Standard
177-01-01	Perforator Assembly
602-160	Plain Bush - crease Guide Block
604-100	Gas Spring - Perf. Unit
604-103	Gas Spring - Delivery
607-005	Belt - Vacuum Roller
607-045	Multi Beam Coupler
607-171	Timing Belt - Drive
607-175	Belt - Drive
607-183	Timing Belt - 190XL 062
681-020	Fuse - 500mA - 20 x 5mm - Anti-surge
681-011	Fuse - 315mA - 20 x 5mm Anti-surge - Ceramic
681-019	Fuse - 6.3A - 20 x 5mm - Anti-surge Ceramic
652-047	Fuse - 15A - 32 x 6.3mm - Anti-surge
613-351	Micro Switch - Guard
613-365	Emergency Stop Switch - Double Pole
626-007	Anti-Static Sensor Bar
652-011	Switch - Low Current Coil - Black
75-512	Anti - Static Transformer - UL
175-28-01	Butterfly Valve - Stepper
76-262	Stepper Motor - Roller Drive
76-258	Stepper Motor - Belt Drive
76-259	Stepper Motor - Roller Position
76-266	Lead - Fold Knives Sensor
124-01-27	Lead - Delivery Roller Pot
175-072-01	Lead - Jam Detector - Emitter
175-072-02	Lead - Jam Detector - Receiver
75-530-01	Transformer Assy. - 230V to 110V

NOTE.....

The items listed above represent parts which are subject to wear, loss, or accidental damage, and is included for your guidance only.

Replacement of parts fitted to your machine require specialist knowledge and should therefore be entrusted to your dealer.

MACHINE CALIBRATION HISTORY

Serial Number:-

Date:-					
Total Count:-					
Vac Suck Trim					
Vac Park Trim					
Stretch					
Lead Edge Trim					
Follow Stretch					
Del. Roller Trim					
Knife 1 Trim					
Knife 2 Trim					
K1 Deflect Trim					
K2 Deflect Trim					
K1 Travel					
K2 Travel					

Date:-					
Total Count:-					
Vac Suck Trim					
Vac Park Trim					
Stretch					
Lead Edge Trim					
Follow Stretch					
Del. Roller Trim					
Knife 1 Trim					
Knife 2 Trim					
K1 Deflect Trim					
K2 Deflect Trim					
K1 Travel					
K2 Travel					

Date:-					
Total Count:-					
Vac Suck Trim					
Vac Park Trim					
Stretch					
Lead Edge Trim					
Follow Stretch					
Del. Roller Trim					
Knife 1 Trim					
Knife 2 Trim					
K1 Deflect Trim					
K2 Deflect Trim					
K1 Travel					
K2 Travel					

FUSE POSITIONS & RATINGS

(POSITION ET CLASSIFICATION DES FUSIBLES)

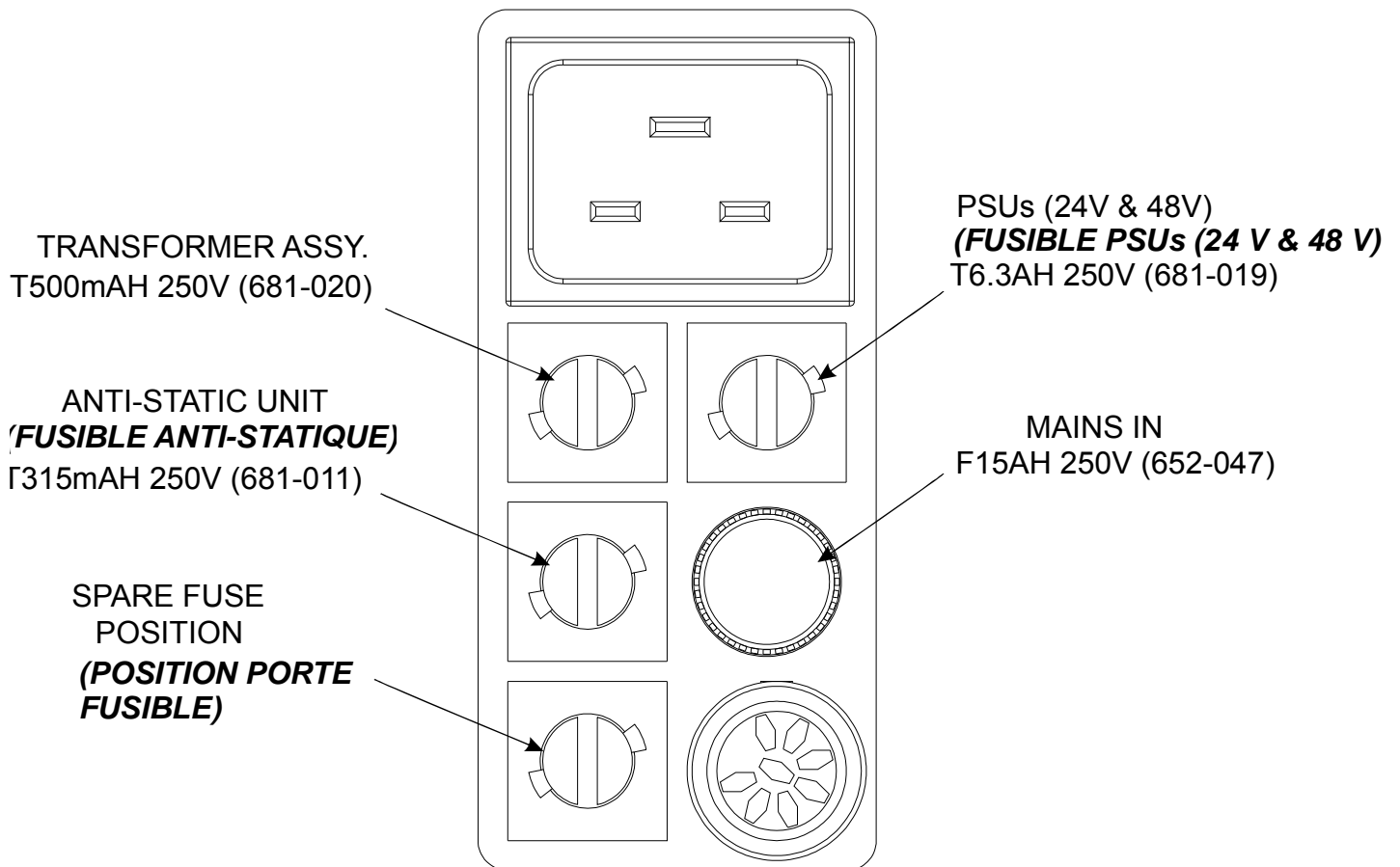

PRODUCT RECYCLING & DISPOSAL

Disposal Information for Commercial Users



Application of this symbol on your equipment is confirmation that you must dispose of this equipment in compliance with agreed national Procedures.

In accordance with European legislation end of life electrical and electronic equipment subject to disposal must be managed within agreed procedures.

Prior to disposal please contact your local dealer or representative for end of life take back information.

Disposal Information for Domestic Users



Application of this symbol on your equipment is confirmation that you should not dispose of the equipment in the normal household waste stream.

In accordance with European legislation, end of life electrical and electronic equipment subject to disposal must be segregated from household waste.

Private households within EU Member States may return used electrical and electronic equipment to designated collection facilities free of charge. Please contact your local disposal authority for information.

In some Member States when you purchase new equipment your local retailer may be required to take back your old equipment free of charge. Please ask your retailer for information.

Other Countries

Please contact your local waste authorities and request disposal information.

REVISION HISTORY

Rev.	Mod No.	Mod Description	Date	Mod By
4	ECO2809	Screen shot graphics changed to show the Lead Edge Sensor Indicator Bar, on all relative pages. New pages inserted to show the Clean Lead Edge Sensor Warning Screens and how to clean the Lead Edge Sensors. (Pages 55 to 57)	02/01/13	BAL