

FORMAX[®]

Cut-True 23S Electric Paper Cutter

TABLE OF CONTENTS

TOPIC	PAGE #
SPECIFICATIONS	1
INSTALLATION	1 - 3
SAFETY PRECAUTIONS	4
OVERVIEW	5 - 6
OPERATION	7 - 8
TROUBLESHOOTING	8
ERROR MESSAGES	9
CHANGING THE CUTTING STICK	9
MAINTENANCE	9
BLADE MAINTENANCE	10
BLADE REPLACEMENT	10 - 11
ADJUSTING BLADE DEPTH	12

SPECIFICATIONS

Cutting Action	Dual-button electric
Maximum Cutting Width	Up to 16.9"
Maximum Paper Stack Height	Up to 1.75"
Cutting Length Behind Blade	17"
Table Size in Front of Blade	8.25"
Narrow Cut	1.89"
Table Size	24.6" W x 27.5" D
LED Cutting Line	Yes
Clamp Style	Spindle-guided clamping wheel
Back Gauge Adjustment	Manual crank
Back Gauge Reading	LED digital display, standard or metric
Blade Change Safety Tool	Included
Dimensions	46.75" H x 24.75" W x 33" D
Weight	198.6 lbs.
Power Supply	110V
Safety Certifications	CE Approved



INSTALLATION

The back gauge crank, clamp hand wheel with screws, tool kit, and blade change tool are packed separately. Some of these items will need to be installed right away.

The installation area must be clear to provide for efficient assembly and maintenance.

Do not install in locations directly exposed to sunlight or near a heat source. Install in a well-ventilated place which is free from dust.

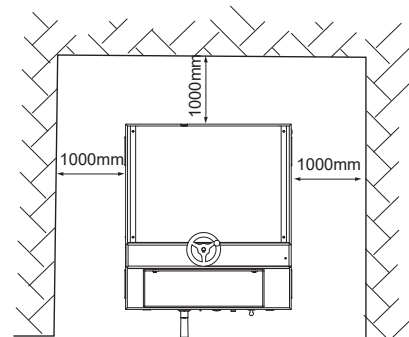
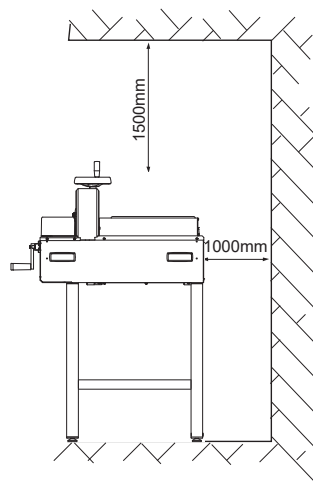
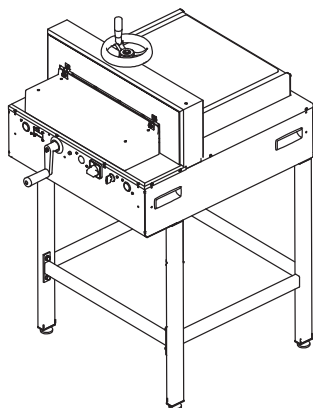
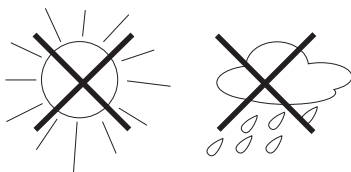

STAND ASSEMBLY & INSTALLATION

Tools required: 13mm wrench

Be sure all parts are present prior to assembly

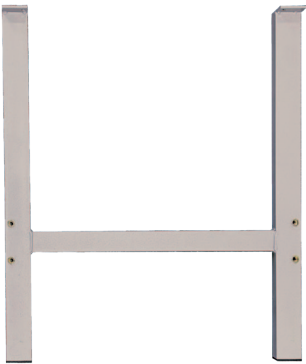

Legs, qty 2



Crossbars, qty 2

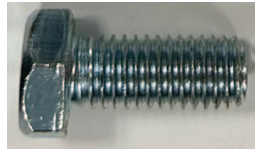

13mm bolts, qty 12
8 for stand, 4 for base



Alignment pins, qty 4



Leveling feet, qty 4

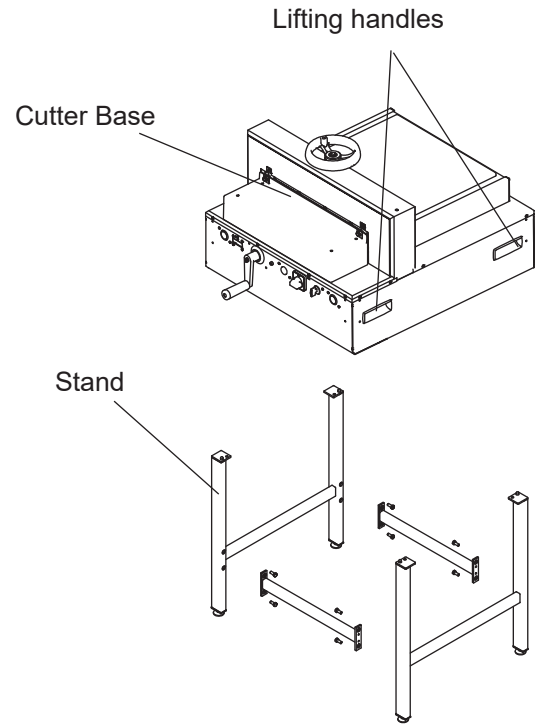

1. Screw the leveling feet into the bottom of the legs. (Fig. 1)

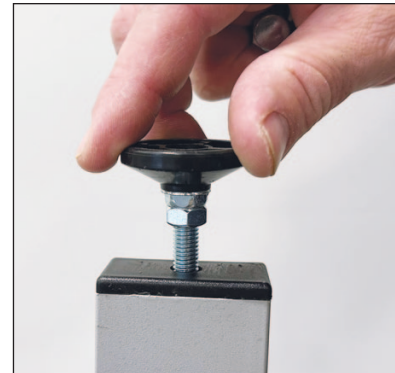

Fig. 1

2. Use the bolts to attach the legs to the crossbars. (Fig. 2)
NOTE: Loosely insert all 4 bolts before securing them into position with a wrench.



Fig. 2

- Place the stand upright with feet on the floor.
Screw the alignment pins into the holes on top of each leg.
(Fig. 3 & 4)

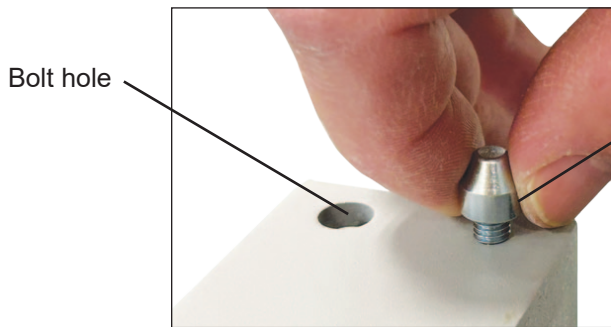

Fig. 3



Fig. 4

- NOTE: TWO people are required to lift the cutter base onto the stand.**

Using the lifting handles on each side (see page 2), place the cutter base on the assembled stand, being sure the alignment pins slide securely into the holes on the cutter base. (Fig. 5)

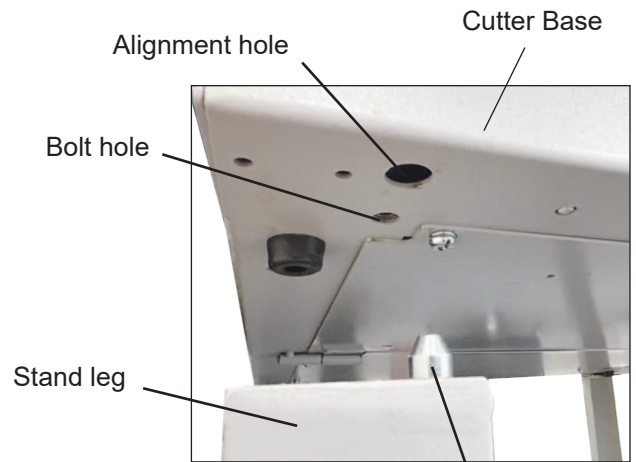

Fig. 5

- Secure the cutter base to the stand with the remaining four bolts. (Fig. 6)

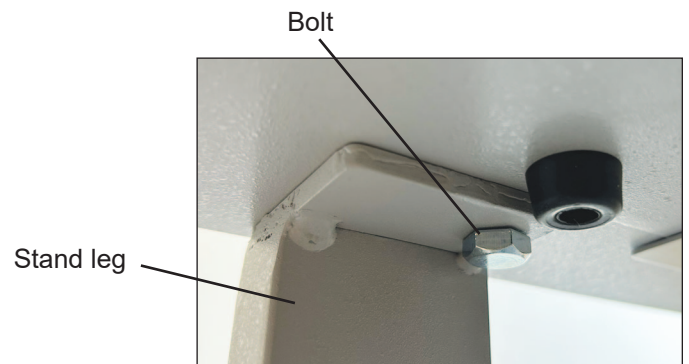

Fig. 6

- Once the cutter is in its final location, adjust the leveling feet (if necessary) with a 13mm wrench. (Fig. 7)



Fig. 7

SAFETY PRECAUTIONS

1. Carefully read this instruction manual before operating the machine.
2. Operators must read and fully understand how to use the safety equipment, and have the ability to follow and implement the regulations stated in this instruction manual.
3. Keep guards/covers in place. All components which may endanger the operator are covered by the guards or covers. Please keep the guards/covers in place and do not remove them without dealer or manufacturer's consent.
4. Don't use it in a dangerous environment. Do not use the machine in humid or damp locations, or directly expose it to rain or sunlight. The working area must be well lit and ventilated.
5. Store idle machine. If you don't use it for a period of time, please store it in a dry and secure environment.
6. Stand in the proper position for operation. Please stand in front of the machine while operating it.
7. Don't overuse the machine. Please use it properly and follow the steps for each of the functions stated in the instruction manual.
8. For safety reasons, do not operate the machine when you are tired or unable to focus on the job.
9. Keep both hands away from the cutting area. The machine is designed to be and only allows a one-person operation. Each single cutting action must be operated by pressing the 2 enable switches simultaneously to avoid injury.
10. Keep away from the sharp edge of the blade. Please wear leather gloves and use the blade change safety tool to replace or install the blade.
11. Maintain machine with care. Repairing the machine or sharpening the blade must be carried out by qualified and well-trained people only. If you don't use the replacement parts from the original manufacturer, it may result in considerable danger to the operator.
12. The measurement of the noise level is defined according to ISO 3746. A weighted sound pressure level measuring under no load at operation position is 75.6Db (A), and under load at operation position is 75.5dB (A).
13. Make sure that the machine is disconnected at the power supply. Shut down the power before starting to do any maintenance, adjustments, or repairs.
14. The cutter is designed for trimming paper only. For safety reasons, do not attempt to cut other materials such as metal sheets, wood board or other objects.
15. Do not use the machine over its capacity. Refer to the specifications of the machine shown in this manual. Any modifications to the machine are not allowed and will terminate the manufacturer's guarantee.
16. To ensure the optimal effectiveness of the machine, the safety devices need to be checked before operation.

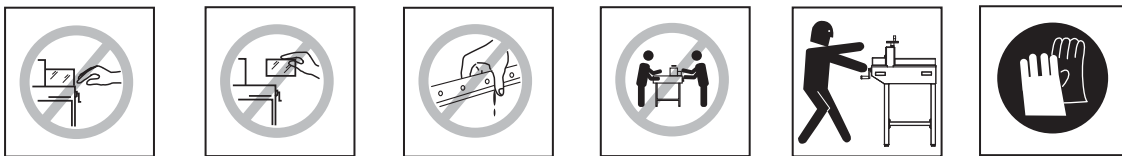

SAFETY INSPECTION BEFORE USE

1. Be sure to check the safety functions before operation and after replacing the cutting blade.
2. The safety devices (SQ1 and SQ2) are designed in accordance with the EN 60947-5-1-3 requirement and the electronic requirement EN1088.
3. The front safety guard is controlled by SQ1 and SQ2, which follow the requirement EN954-4 category sub. 3. The machine and blade will automatically stop when the safety guard is open or disconnected. With the safety guard closed, the machine can be operated by pressing the two enable switches simultaneously.

OVERVIEW

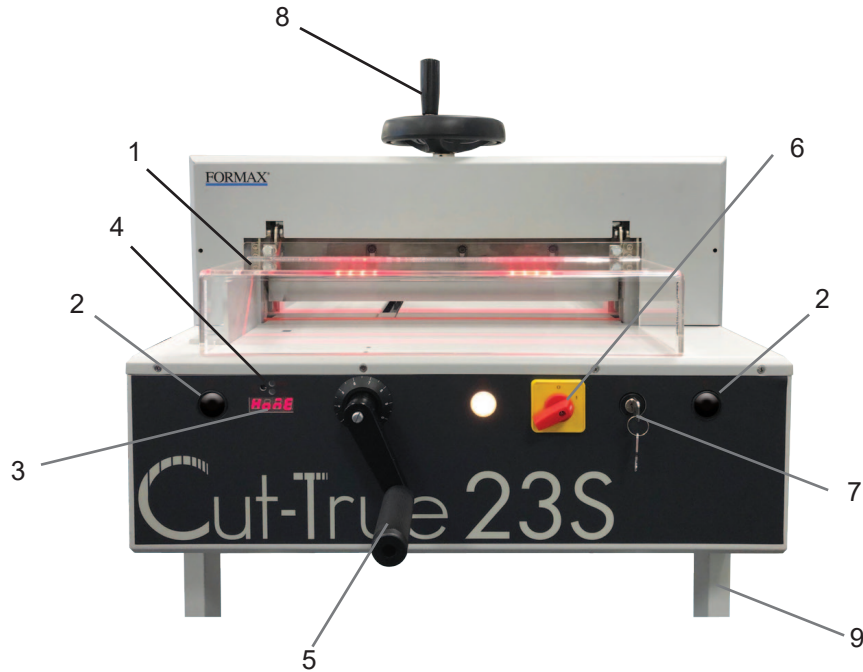

1.	Plexiglass safety cover	Helps to keep hands away from the cutting area. Must be closed in order to operate the cutting blade.
2.	Activation switches	These two switches must be pushed simultaneously to engage the cutting blade.
3.	LED measurement display	Shows the position of the back gauge. Can be displayed in inches or millimeters.
4.	LED display unit selector	Allows users to switch between inches or millimeters on the LED measurement display.
5.	Back gauge hand crank	To engage the crank, push it towards the machine, then turn. To release, pull the crank toward the operator. To move the back gauge forward toward the operator, turn clockwise. To move the back gauge back away from the operator, turn counterclockwise. The ring behind the crank is used for fine adjustments. "O" indicates a whole cm, "1-9" indicates corresponding mm.
6.	Power switch	Turns on/off the main power to the cutter.
7.	Key operation select switch	Turn to the right for cutting operations. Turn to the left for blade replacement operations. Move to the middle to stop all operations.
8.	Spindle-Guided Clamp System	Holds the paper stack securely while cutting. Turn the hand wheel clockwise to lower the clamp. Turn it counterclockwise to release.
9.	Stand	Steel stand, assembly required (see pages 2 and 3).

OVERVIEW

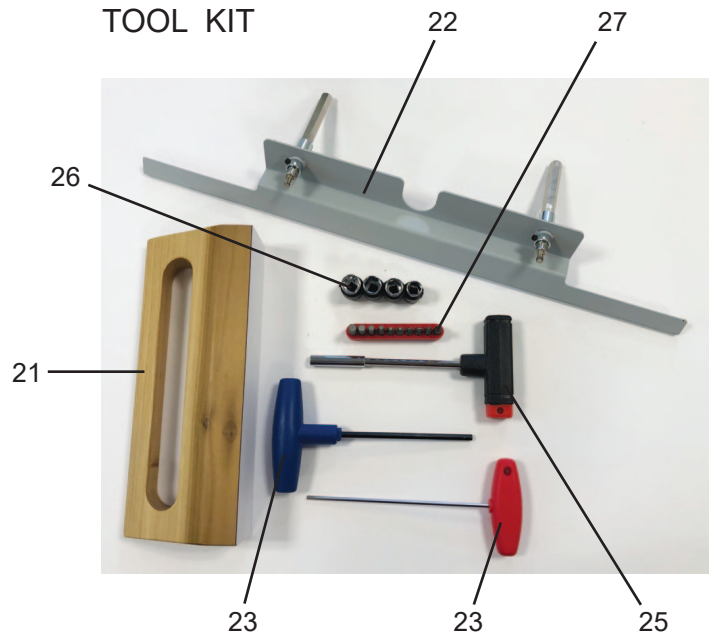
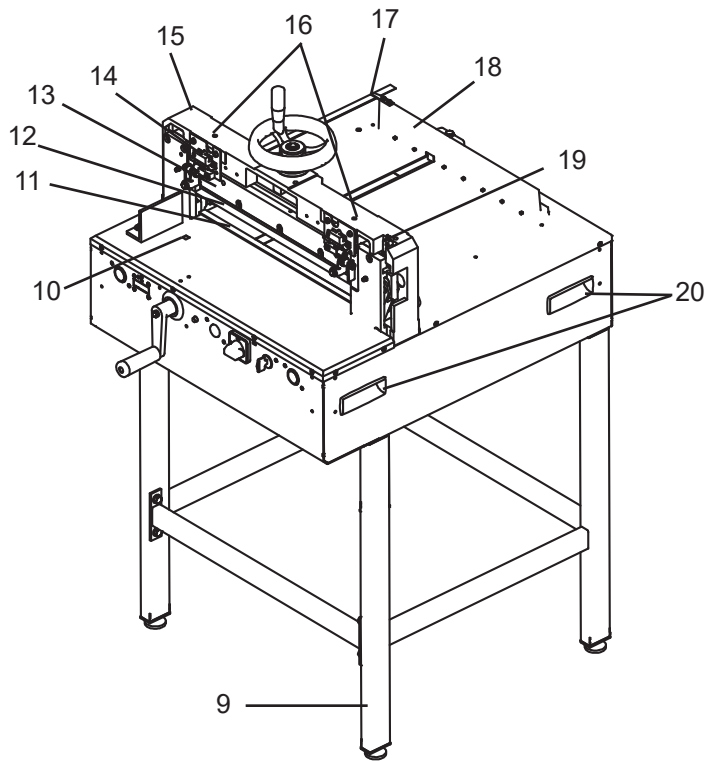

9.	Stand	Steel stand, assembly required (see pages 2 and 3).
10.	Cutting stick access port	See page 7 for directions on changing the cutting stick.
11.	Cutting stick	Made of tough plastic to protect blade. Can be turned to use all 4 surfaces.
12.	Blade	Heat-treated high-carbon steel blade.
13.	Blade carrier	Holds the blade during operation. Blade is attached with 5 screws.
14.	Safety interlock system	Prevents blade movement when the safety cover is open, or when the 5mm T-wrench is in the blade fine adjustment access port (see part #19 below).
15.	Cutter base	Houses the blade carrier, blade, and the cutting mechanism.
16.	Blade balance screws	3 socket headless screws are used to adjust blade balance after replacement.
17.	Side gauge with scale	Indicates the position of the back gauge in inches or millimeters.
18.	Back gauge	Controlled by the hand crank (#5) to position the paper stack for cutting.
19.	Blade fine adjustment access	Blade height can be adjusted up to 2mm by using the adjustment screw. (See page 10 for instructions.)
20.	Lifting handles	Used when mounting base to stand, or when moving it to a tabletop location.
21.	Wooden push block	Helps align paper stacks for precise cutting.
22.	Blade change safety tool	Safely removes the cutting blade. See page 8 for directions on using the tool.
23.	Blue T-wrench	Used to adjust the blade height (page 10).
24.	Red T-wrench	Used to pop the cutting stick out of its channel for replacement (page 7).
25.	T-driver (black/red handle)	Use this with the driver bits to adjust or remove blade screws.
26.	Socket bits	
27.	Driver bits	Use with the T-driver to adjust or remove blade screws.

OPERATION

1. Turn on power switch. The LED display will flash "HOME." Push the back gauge crank toward the machine to engage it, then turn clockwise to bring the back gauge to the front to set the "home" registration. When it's set, the display will change from "HOME" to a numerical measurement.

Turn the crank counterclockwise to move the back gauge to the correct cutting position.

Check the LED display to determine position.

NOTE: The LED display can be set to inches or millimeters. To switch between units, insert a narrow tool into the hole next to the inch/mm LEDs.

NOTE: To prevent the back gauge from moving during paper positioning or cutting, pull the crank slightly toward the operator to make it idle.

2. Open the plexiglass safety cover.
3. Insert paper stack and align with the back gauge and left side guide.

4. The LED cutting line will indicate where the blade will cut. Fine tune the position if necessary using the back gauge crank and the LED display.

5. Turn the clamp hand wheel clockwise to securely clamp the paper pile.

6. Close the plexiglass safety cover.

NOTE: The blade will not engage if the safety cover is open.

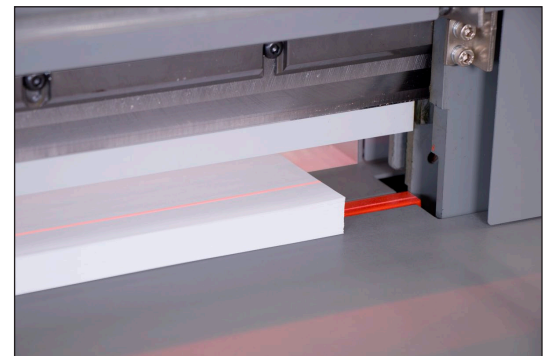
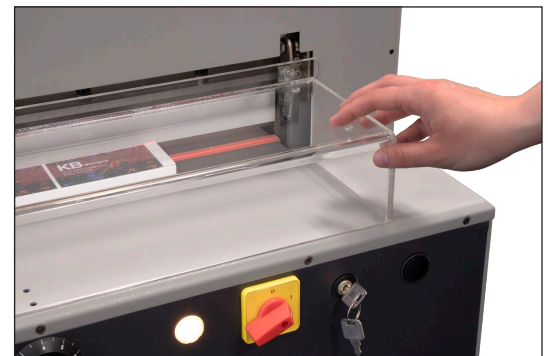

OPERATION, continued

7. Push the 2 operation enable switches simultaneously and hold them until the cutting cycle is complete.



8. Open the plexiglass safety cover and remove paper.

NOTE: The cutting blade will not engage if the plexiglass safety cover is open.

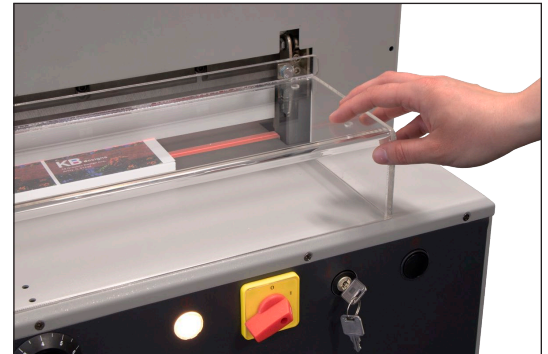

TROUBLESHOOTING

PROBLEM:	CHECK THIS:	SOLUTION:
Blade does not move	Check that the power is on.	Be sure power cable is plugged in. Check that the red power switch is turned on.
	Is the plexiglass safety cover fully lowered?	Fully close the safety cover.
	Are both enable buttons being pushed simultaneously?	Be sure cover is closed and press both buttons simultaneously.
Cutter has no power	Check the power source.	Confirm power is reaching the cutter.
	Was the cutter overloaded with too much paper?	Wait until the breaker automatically resets (30-60 seconds). The indicator light will be off. Reduce the size of the paper stack.
Blade is not cutting the last piece of paper in the stack	Does the cutting stick need to be rotated or replaced?	Rotate or replace cutting stick (page 7).
	Is the blade depth adjusted properly?	Adjust blade depth (page 10).
	Does the blade need to be replaced?	Replace blade using blade change safety tool (page 8).

ERROR MESSAGES

“**CUT2000**” appears in the LED display: the blade has completed 2,000 cutting passes.

Check the blade to see if it is dull or still sharp enough to cut through one sheet of copy paper.

If the blade is still sharp and does not need to be replaced, reset the counter with the following steps:

1. Turn the select switch key to the right.
2. Press and hold the right enable switch for at least 5 seconds, while simultaneously turning the select switch key back to the middle position until the message “CAT” appears in the LED display.
3. Release the right enable switch.

“**E4**” appears in the LED display: Remove the T-wrench from the fine adjustment device.

“**E5**” appears in the LED display: Cutting drive motor is overloaded.

“**E6**” appears in the LED display: The blade couldn't return within the standard period of time after cutting.

ROTATING / REPLACING THE CUTTING STICK

The cutting stick is the surface the blade contacts during the cutting process. It can be rotated and used on each side, 4 times altogether.

If the last piece of paper in the stack is not cut through cleanly, and the blade depth has been adjusted properly, the cutting stick should be rotated or replaced.

The cutting stick sits in a channel in the base of the cutter, just below the blade carrier. To remove it, first turn off the power. Then insert the red T-wrench from the tool kit or a small screwdriver into the cutting stick access slot (see photo below left) and press down. Grasp the cutting stick and remove (see photo below right). Rotate the cutting stick to a new side and re-install. If all four sides have been cut, the stick must be replaced.

NOTE: When the cutting stick is rotated or replaced, the blade height must be readjusted. See page 10 for blade height adjustment instructions.

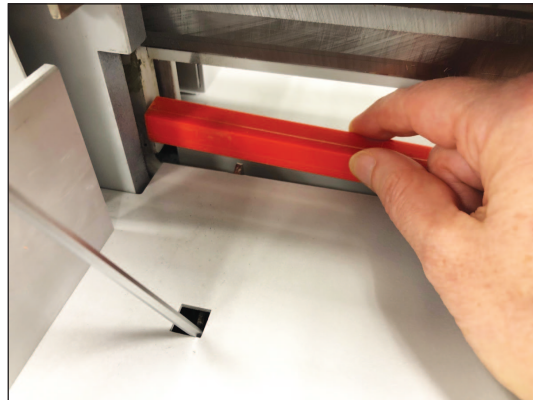
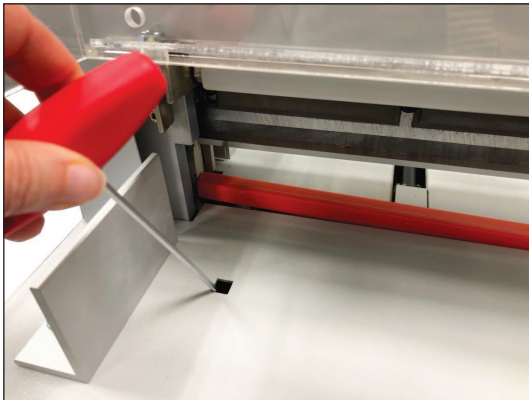

MAINTENANCE AND LUBRICATION

1. Use a dry cloth to wipe surfaces. Do not pour water directly onto the machine. Do not use a brush, acid, or solvents such as benzene, hot water, etc. This will damage the paint.
2. All moveable parts need to be lubricated and oiled from time to time. These parts must be cleaned and free of paper dust and oil deposits before lubricating.

CUTTING BLADE MAINTENANCE

The cutting blade is made of heat-treated high-carbon steel and is designed for repeated use. However, over time the blade will become dull and not perform to the highest standards. Cutting heavy paper or cardboard will dull the blade more quickly than thinner paper stock. A dull blade will not cut accurately. Blade lifetime with normal copy paper is approximately 1,600 cuts (tested in maximum capacity).

NOTE: If the blade jams in the paper stack or leaves a groove in the paper, it should be changed immediately.

If the blade is not making clean, accurate cuts, check the following:

- * Have you rotated or replaced the cutting stick?
- * Have you correctly adjusted the height of the blade?

If so, the blade will need to be replaced. The blade can either be re-sharpened by a professional, or it can be replaced with a new blade. To avoid injury, follow the Blade Changing Procedure and use the Blade Change Safety Tool, included with the cutter.

BLADE REPLACEMENT PROCEDURE

1. Turn the power switch ON, and turn the select switch to the left.

Select switch in blade change position

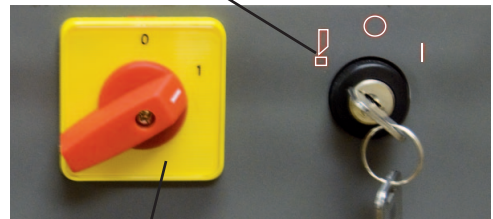

Power switch in ON position

2. Press two enable switches simultaneously to move the blade down to the bottom position.



3. Turn the select switch to the middle and turn the power switch off.

Lift the plexi safety cover.

Use the T-driver and #4 driver bit to remove the first screw from the right side of the blade (A).

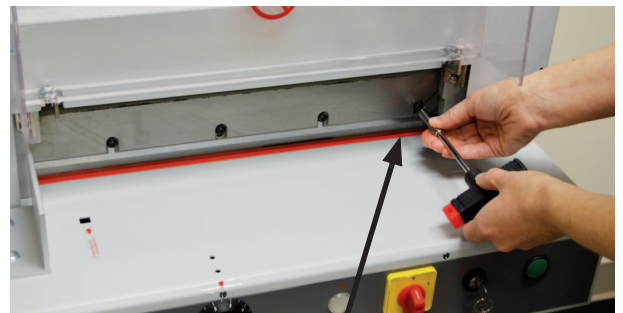

A

4. Close the safety cover, then turn on the power switch.

Turn the select key switch to the left.

The blade will raise automatically.

Turn the select switch to the middle and turn off the power switch.

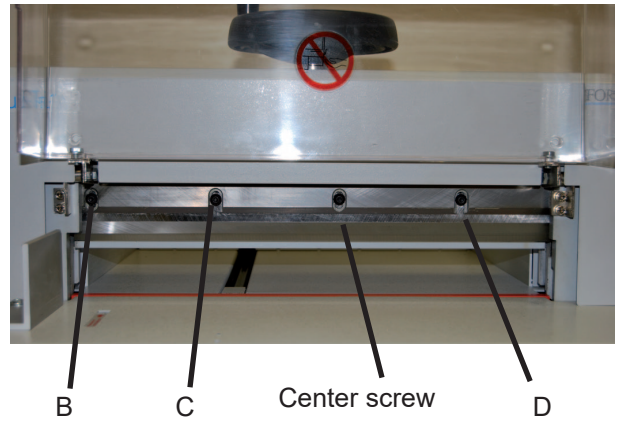

5. Raise the safety cover and remove the first screw from the left side (B).

Remove the screws to the left and right of center (C & D), but leave the center screw in place.

NOTE: Do not remove the center screw.

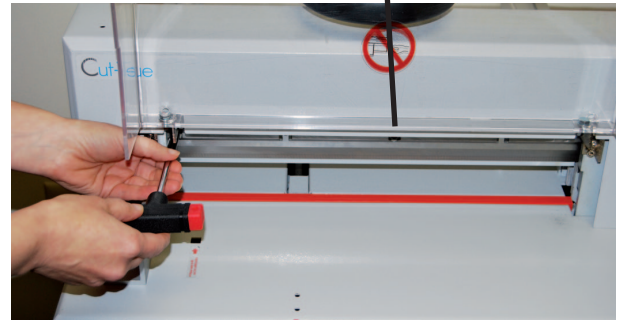

6. Hold the blade change safety tool by the two silver handles.

Screw the handles into the holes to the left and right of center (see photo).

Screw them in tightly, to prevent the blade from falling out of the blade change safety tool.



Blade change safety tool in place

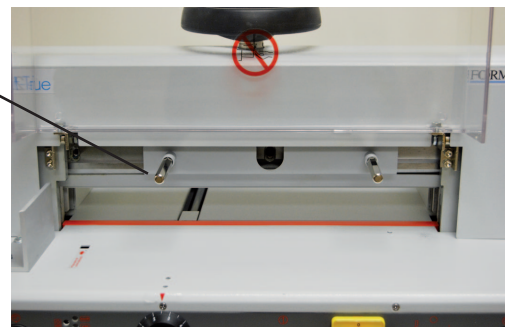

7. Remove the center screw.



8. Grip and loosen both of the blade change tool handles by turning just a half reverse turn to remove the blade from the machine.

Carefully move the blade and holder downward in order to remove it safely from the machine.

NOTE: Be careful to avoid injury from the very sharp blade.

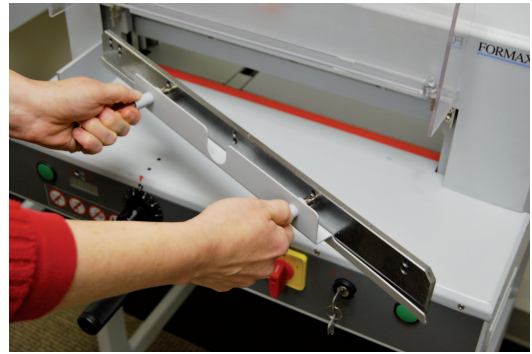

9. To carefully remove the old blade from the blade change safety tool, set it on a flat surface and unscrew the handles.

Cap the old blade with a protective pad to prevent injury.

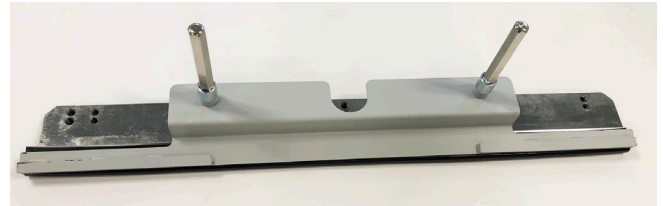

10. Place the new blade with the beveled cutting edge facing up, as shown here. Remove the protective pad from the new blade.

To attach the blade change tool, place it over the blade and screw the handles into the **lower set of screw holes**.

NOTE: BE SURE TO USE THE LOWER SET OF SCREW HOLES TO PREVENT DAMAGE.

Reverse the procedure to install the new blade.

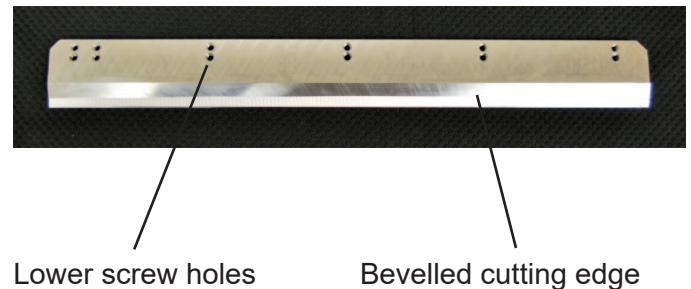

ADJUSTING BLADE DEPTH

The blade depth should be adjusted after each cutting stick rotation/replacement to prolong the life of the blade and cutting stick. Adjustment may or may not be needed after blade replacement.

To determine if adjustment is needed, perform a test cut with a small stack of paper. If the blade is adjusted too low, it will cut deeply into the cutting stick, damaging not only the stick but the cutting blade. Optimal blade height is when the last sheet in a stack is cut accurately.

Use a the Blue T-wrench or a #5 Allen wrench when making adjustments.

Make adjustments in very small increments, remove the tool, then perform another test cut. Repeat until blade is positioned correctly.

Insert the tool into the Blade fine adjustment access (page 4, part #19).

NOTE: The adjustment tool MUST BE REMOVED EACH TIME before performing a test cut.

If the blade cuts too deeply, adjust clockwise toward the “-” direction.

If it does not cut deeply enough (the last sheet in the stack is not cut accurately), adjust counterclockwise toward the “+” direction.

