

FORMAX[®]

FD 402A1

High-Capacity Air Jogger

OPERATOR / PARTS MANUAL
FIRST EDITION

TABLE OF CONTENTS

SUBJECT	PAGE
DESCRIPTION	1
SPECIFICATIONS	1
UNPACKING	1
SAFETY	1
FEATURES & CONTROL PANEL	2
OPERATION	3
BASIC JOGGING	3
PAPER TRAY TILT ADJUSTMENT	3
USING THE TIMER	4
TROUBLESHOOTING	4
DAILY MAINTENANCE	4
PARTS LIST	6

DESCRIPTION

FUNCTION

The FD 402A1 High-Capacity Air Jogger aligns and dries printed sheets in a single process while reducing static electricity. Variable vibration speed and air pressure controls combine to reduce jogging time, allowing press sheets and digital printouts to be air-dried immediately.

SPECIFICATIONS

Variable Vibration Speed:	Up to 3,000 vpm
Variable Air Control:	Up to 29,000 rpm
Bin Size:	3.75" D x 20.375" W
Media Size:	5" x 7" Min up to 11" x 17" Max
Sheet Capacity:	Up to 940 sheets 20#
Dimensions:	16" W x 16" L x 43" H
Weight:	77 lbs.
Voltage:	110 Volts (50Hz)
Safety Certifications:	CE approved



UNPACKING

1. Check package for shipping damage. If there is shipping damage, do not discard the box.
2. Remove the machine and packed components from the box.

SAFETY PRECAUTIONS

- Place the machine on a level and stable surface, to prevent it from falling over and causing personal injury or damage to the machine. Avoid locations with direct sunlight, excessive dust and/or dirt, chemicals, salt or vibrations.
- Connect the power plug to a grounded outlet and do not use any other voltage other than specified on the serial plate. Do not share a wall outlet with another piece of equipment as overheating could occur. Be sure to route the power cable to the wall outlet in a way which will prevent people from tripping over it.
- When cleaning the machine, turn off the power first, then unplug from the wall outlet.
- Do not dismantle or attempt to repair the machine. Do not lubricate or apply grease to the machine. Call for service.

FEATURES & CONTROL PANEL

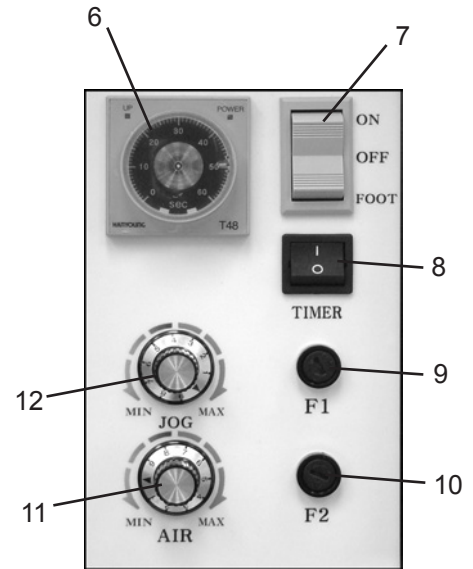
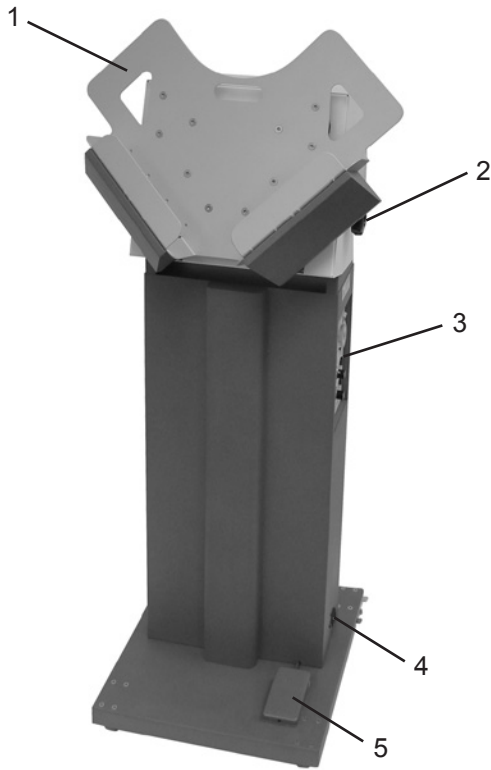

Control Panel

No.	NAME	FUNCTION
1	Paper Tray	Holds paper for jogging
2	Tray Tilt Adjustment Knob	Used to alter the tilt angle of the paper tray
3	Control Panel	Controls all functions of the jogger
4	Power Cord Receptacle	Input power cord
5	Foot Switch	Used for hands-free operation
6	Timer Adjustment Knob	Choose jogging duration, from 0-60 seconds
7	3-Way Power Switch	Provides different functions in combination with the Timer Knob (see page 4)
8	Timer Off/On Switch	Toggles between timed and untimed jogging (I = on, O = off)
9	Fuse 1 (3A)	Fuse for jogging
10	Fuse 2 (7A)	Fuse for air
11	Air Adjustment Knob	Turn right for stronger air pressure, turn left for less air, all the way left for no air
12	Jog Speed Adjustment Knob	Turn right for increased vibrations, turn left for decreased vibrations

OPERATION

Basic Jogging

When the AIR adjustment knob is turned to the right (ON), air blows through vents in the paper tray while the machine is operating.

When the JOG adjustment knob is turned to the right (ON), the paper tray vibrates.

For jogging regular paper, both switches should be set to ON, while the air-only option can be used to loosen paper or dry ink.

Power Switch Setting	Timer Setting	Result
ON	OFF	Jogger operates continuously
ON	ON	Operation begins immediately
FOOT	OFF	Jogger operates continuously once foot switch is pressed
FOOT	ON	Operation begins by stepping on the foot switch

Paper Tray Tilt Adjustment

1. Hold the lower center of the paper tray. **NOTE:** Keep hands and fingers away from the lower portion of the paper tray to avoid injury.
2. Loosen the tilt adjustment knob and adjust tilt angle.
3. Tighten adjustment knob. Be sure it is well tightened so it won't become loose during jogging.

In general, the paper tray is tilted vertically for thick paper (Fig. 1). For thin paper, set the paper tray horizontally to prevent the paper from being bent and folding over. (Fig. 2).

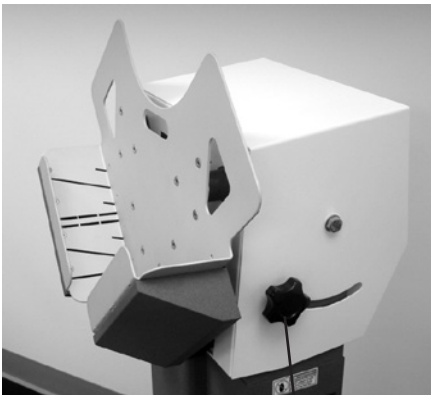

Fig. 1

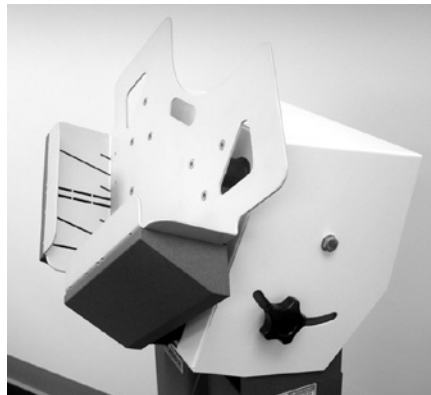

Fig. 2

Tilt Adjustment Knob

Keep fingers away from this area when adjusting tilt angle

Using the Timer

1. Set Timer switch to on (I).
2. Turn the Timer Adjustment Knob to the desired length of time you wish to jog. Choose from 0 to 60 seconds.
3. If the Power Switch is set to FOOT, air blow and vibrations begin when the foot switch is stepped on once. Jogging and air blow will stop when the set time has passed.
4. If the Foot Switch is stepped on continuously, only the air blow will stop when the set time has passed. Then when the Foot Switch is released jogging will also stop. Adjust depending on paper conditions.

TROUBLESHOOTING

TROUBLE	POSSIBLE CAUSE	REMEDY
Paper is not jogged completely	Paper is a non-standard size	Jog it while loosening it by hand.
	Paper has static electricity	Add some space between the sheets by hand.
	Too much paper in paper tray	Reduce the volume of paper jogged at one time.
Air blow is weak	Air adjustment knob is set to low volume	Turn knob to the right to increase air flow.
	Paper or paper scrap is lodged in air inlet or outlet	Clear air inlet and/or outlet.
	If air flow problem is not fixed following these suggestions, blower maintenance may be required. Call for service.	
No air is discharged	Air adjustment knob is set to OFF	Turn knob to the right to increase air flow.
	Fuse 2 is blown	Replace Fuse 2
	If the fuse is blown again after replacement, the cause may be within the machine. Call for service.	
Paper tray will not vibrate	Jogger adjustment knob is set to OFF	Turn knob to the right to increase vibrations
	Fuse 1 is blown	Replace Fuse 1
	If the fuse is blown again after replacement, the cause may be within the machine. Call for service.	

DAILY MAINTENANCE

Clean the air outlet vents in the paper tray to remove paper scraps or dust.

Clean the air inlet filter (located on the left side of the machine) on a regular basis.

PARTS

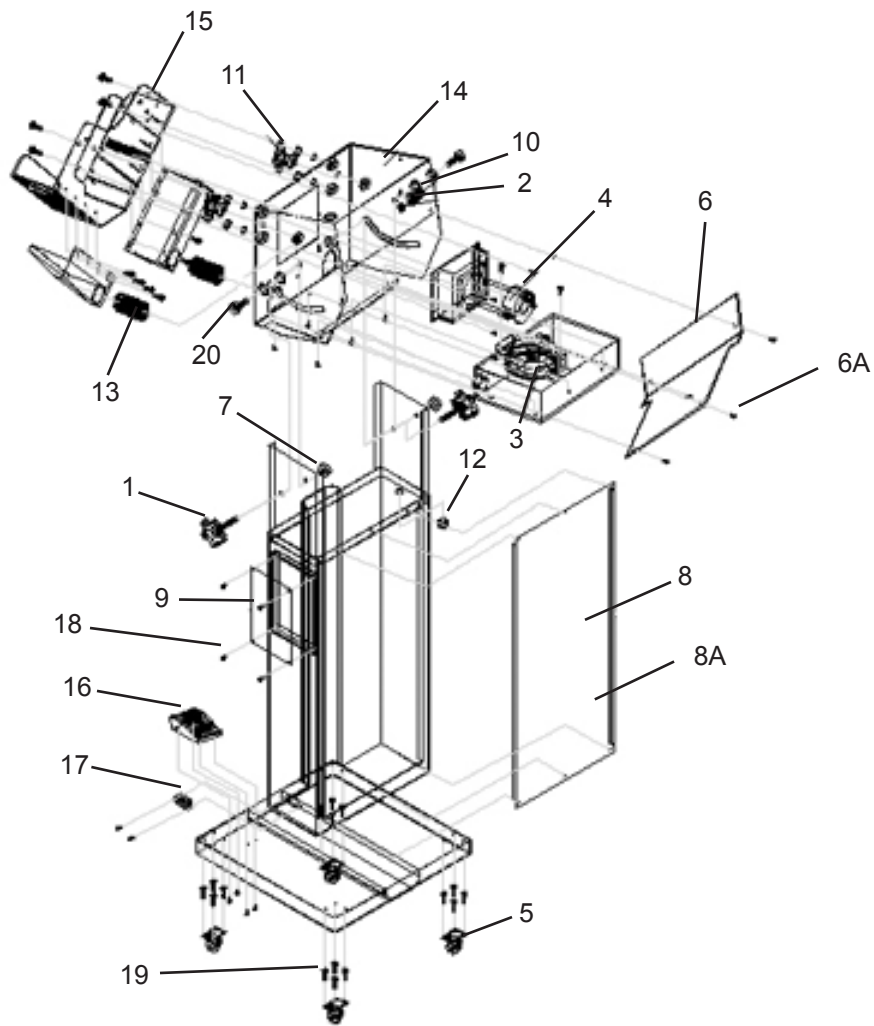

ITEM #	PART #	DESCRIPTION	QTY
1	40213	TILT ADJUSTMENT KNOB	2
2	40214	2P CONNECTOR	1
3	40215	FAN MOTOR	1
4	40216	DC MOTOR	1
5	40217	CASTERS	4
6	40218	HEAD CASE COVER	1
6A	40258	HEAD CASE COVER SCREWS - BUTTON HEAD, PHILLIPS	4
7	40219	BODY CASE	1
8	40220	BODY BACK COVER	1
8A	40259	BODY BACK COVER SCREWS - BUTTON HEAD, PHILLIPS	6

9	40221	CONTROL PANEL	1
10	40222	NOISE FILTER	1
11	40223	VIBRATION SUCTION RUBBER	3
12	40238	RUBBER BOOT	1
13	40225	RUBBER BLOWER TUBE	2
14	40260	HEAD CASE	1
15	40261	PAPER TRAY	1
16	40228	FOOT PEDAL	1
17	40229	BODY SUPPORT	1
18	40230	CONTROL PANEL MOUNTING SCREWS	4
19	40231	CASTER MOUNTING SCREWS	16
20	40232	HEAD CASE BOLTS	2

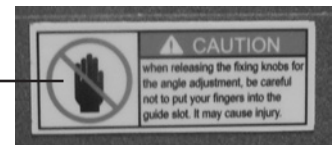
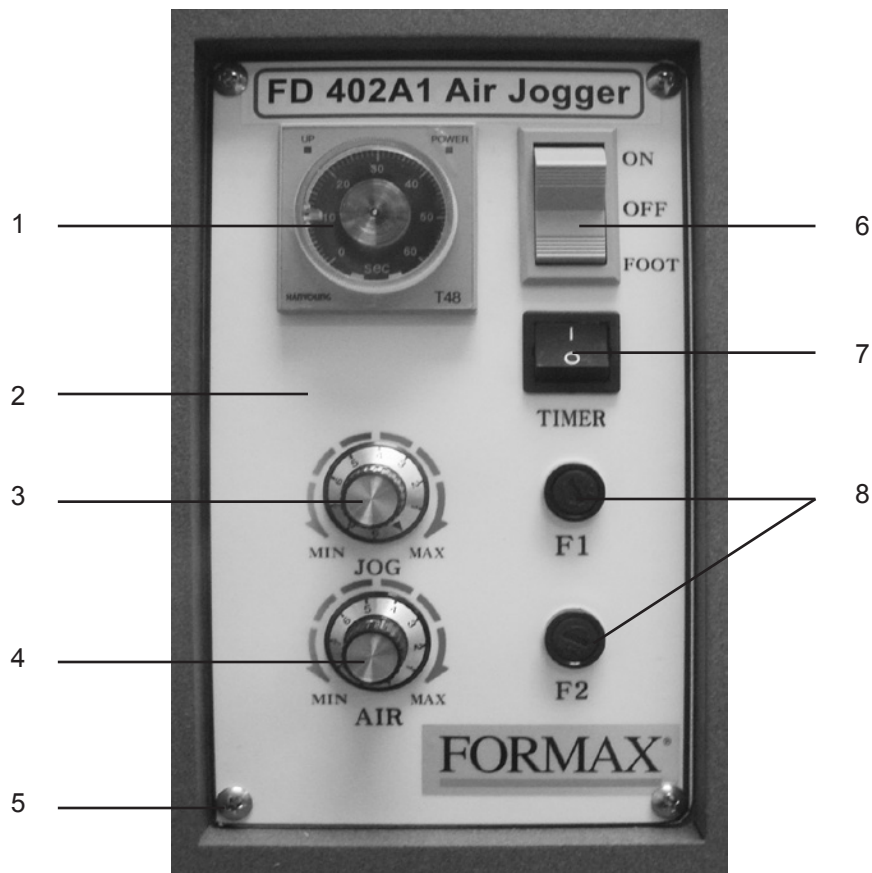

ITEM #	PART #	DESCRIPTION	QTY
1	40226	TIMER SWITCH	1
2	40221	CONTROL PANEL	1
3	40212	JOG SPEED CONTROL W/ ADJUST KNOB	1
4	40211	AIR BLOW ADJUST KNOB	1
5	40230	CONTROL PANEL MOUNTING SCREWS	4
6	40227	ON / FOOT / OFF POWER SWITCH	1
7	40228A	TIMER ON-OFF ROCKER SWITCH	1
8	40233	FUSE HOLDER	2
9	40250	CAUTION LABEL	1

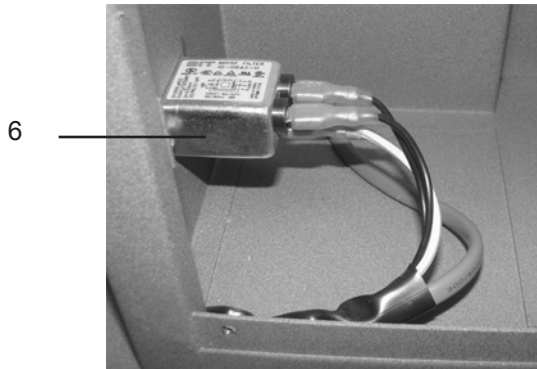
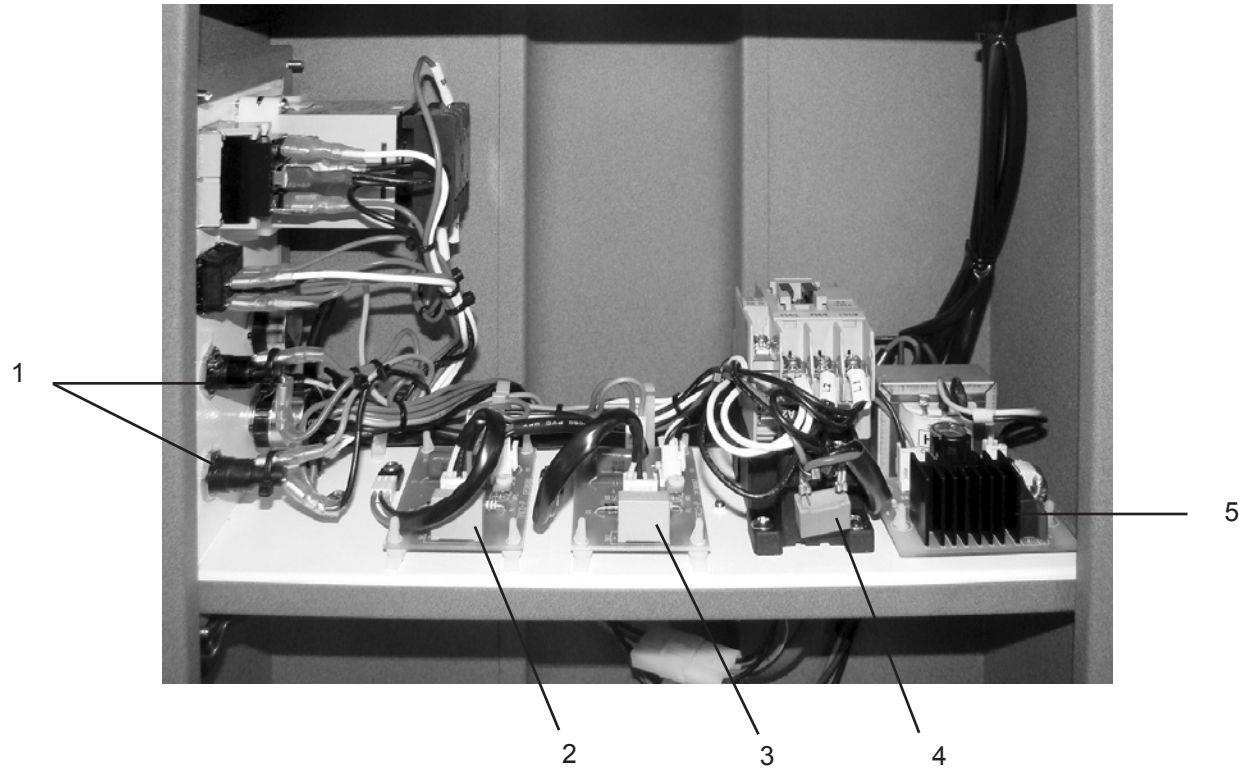

ITEM #	PART #	DESCRIPTION	QTY
1	40233	FUSE HOLDER	2
2	40234	VIBRATION MOTOR PCB	1
3	40252	FAN MOTOR PCB	1
4	40235	MAGNETIC CORE (CONTACTOR)	1
5	40257	POWER BOARD	1
6	40251	POWER INLET / FILTER RECEPTACLE	1
7	40228	FOOT PEDAL	1

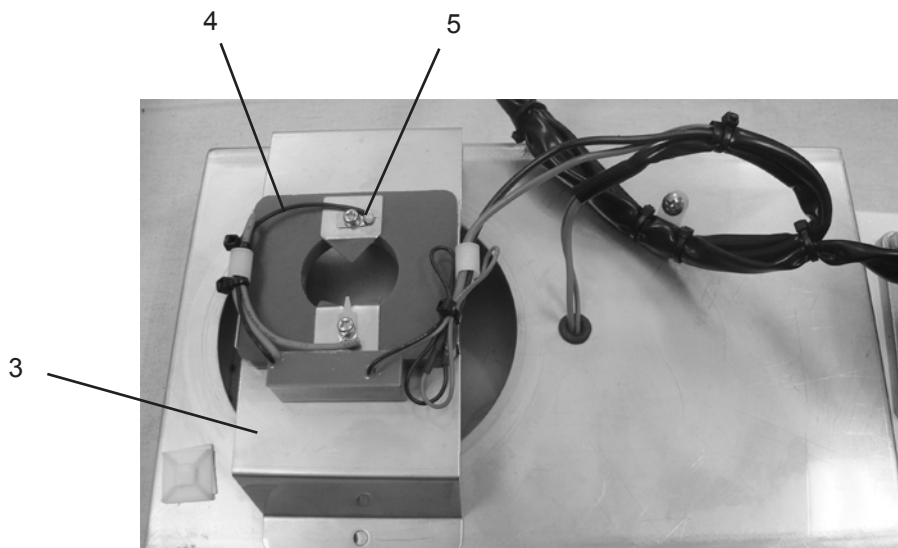

ITEM #	PART #	DESCRIPTION	QTY
1	40238	RUBBER BOOT	1
2	40215	FAN MOTOR	1
3	40253	PLATE	1
4	40254	115 VAC MAGNET	1
5	40245	MAGNET SCREWS	2

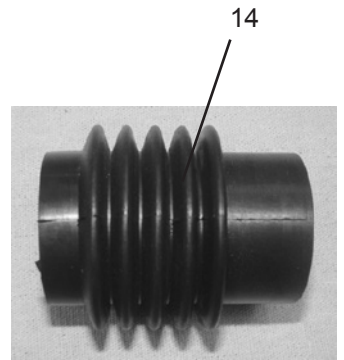
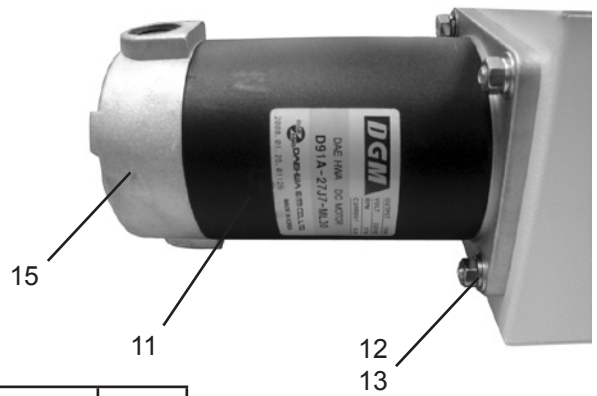
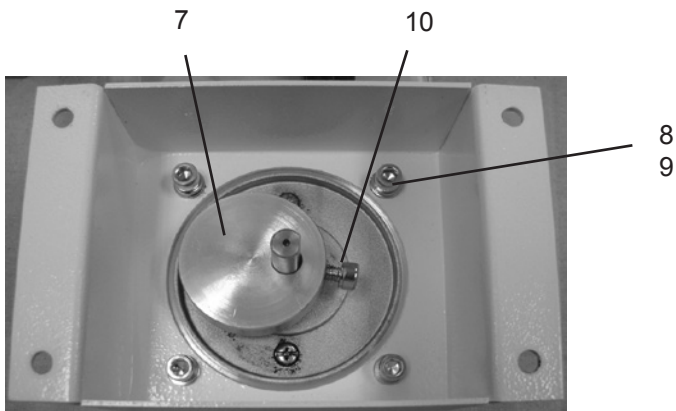
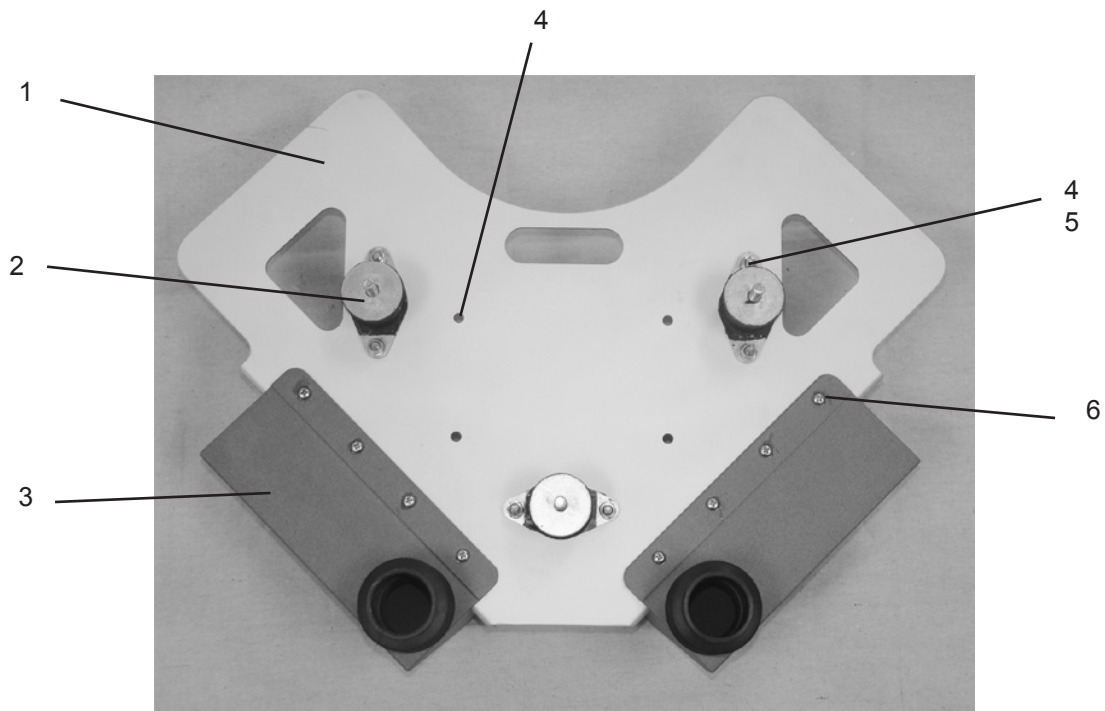

ITEM #	PART #	DESCRIPTION	QTY
1	40261	PAPER TRAY	1
2	40244	RUBBER MOUNT	3
3	40256	AIR CANISTERS	2
4	40236	PAPER TRAY MOUNTING BOLTS, HEX	10
5	40246	PAPER TRAY MOUNTING NUTS	10
6	40247	AIR CANISTER MOUNTING SCREWS	8
NS	40248	AIR CANISTER HEX HEAD MOUNTING SCREWS	8
7	40243	WEIGHT	1
8	40237	HEX HEAD SCREW	4
9	40239	LOCK WASHER	4
10	40242	WEIGHT SCREW	1
11	40216	DC MOTOR	1
12	40240	LOCK WASHER	4
13	40241	NUT	4
14	40225	RUBBER BLOWER TUBE	2
15	40216C	DC MOTOR COVER	1