

# FORMAX<sup>®</sup>

---

FD 372  
Document Folder

Operator Manual  
First Edition

# Introduction

Thank you very much for purchasing the FD 372 Document Folder. This machine enables users to achieve greater efficiency at work by releasing them from paper-folding work that has manually been performed in the past. Please read this Operation Manual carefully before using this machine.

# Contents





Introduction .....	1
Contents .....	1
(1) Specifications .....	2
(2) Accessories .....	3
(3) Parts Names.....	4
(4) Designation and Functions of Operation Panel.....	5
(5) Counter Indication .....	6
(A) Addition Counter .....	6
(B) Batch Counter.....	7
(6) Preparation .....	8
(7) Operation.....	10
(A) Standard Folding of Standard-Size Paper.....	10
(B) Standard Folding of Non-Standard-Size Paper .....	12
(C) Cross Folding .....	15
(8) Adjustments.....	16
(A) Skew Adjustments.....	16
(B) Fine Adjustments .....	18
Fine Adjustments for Table 1 .....	18
Fine Adjustments for Table 2 .....	19
(9) Storing Custom Folds in Memory.....	20
(A) Memory Storage.....	20
(B) Cancellation of memory .....	21
(C) Cancellation of total memory .....	22

## (1) Specifications

Model:	FD 372
Paper sizes:	3.5" x 5.0" to 11" x 17" Smaller size for single fold only.
Paper quality:	High-quality paper, high-quality paper for stencil printing, medium-quality paper
Fold types:	Single, Gate, Letter, Zigzag, Double Parallel, and Fold-out In addition, irregular folds and cross fold using double fold are available.
Fold dimensions:	Maximum fold dimensions Table 1: 13" (zigzag, double parallel, and fold-out) Table 2: 9 ½" (single, gate, and letter)
	Minimum fold dimensions Table 1: 2" (gate and letter) Table 2: 1 ½" (single, zigzag, double parallel, and fold-out)
Paper feed system:	Three-roller friction feed system
Maximum capacity:	500 sheets (20lb)
Folding speed:	3240 to 11000 sheets per hour (single fold using 8 ½" x 11")
Control system:	Automatic setting by a built-in microcomputer
Additional functions:	Skew adjustment memory, paper jam detector, four-digit counter with addition/subtraction modes, and automatic paper size detector Auxiliary paper guide for cross fold A perforator can be installed (optional)
Power consumption:	75W
Power source:	110V, 50Hz 110V 60Hz
Dimensions:	W 29 ½" x D 21 ½" x H 21" (during use) W 22" x D 21 ½" x H 21" (during storage)
Net weight:	85lb
Option:	Perforator table assembly with a 2-mm or 4-mm perforation cutter

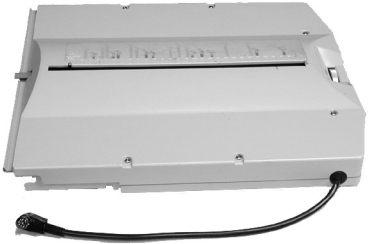
## (2) Accessories

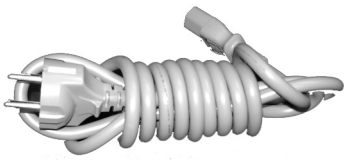
Make sure that the following accessories are included in the package after opening it. Contact your sales agency immediately if there are missing accessories.

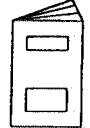
Accessories	Number	Figure
Table 1	1	
Table 2	1	
Power source cord	1	
Paper support guides (right and left)	2	
Machine cover	1	
Operation Manual	1	

### (3) Description of Parts

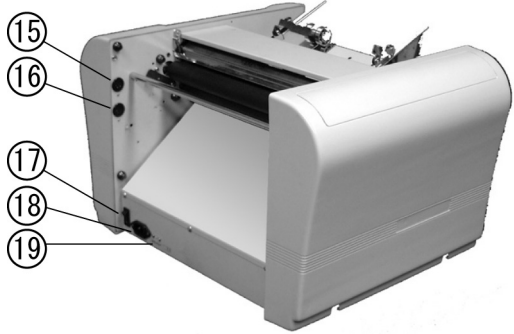
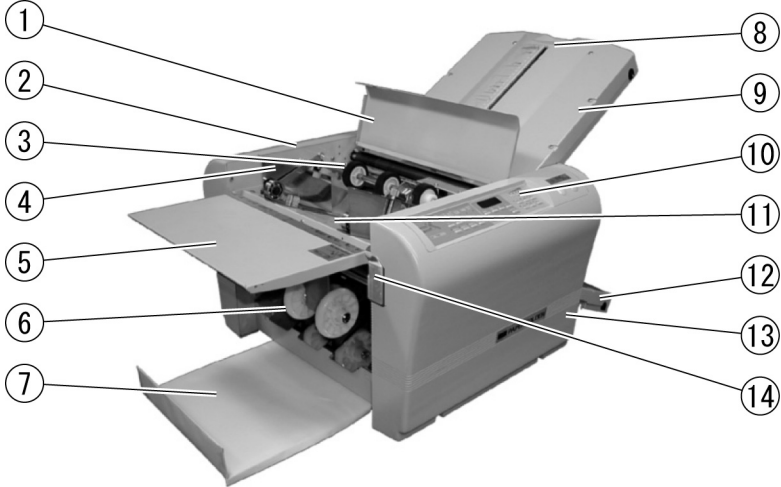

Number	Name	Number	Name
1	Roller cover	11	Paper feed table
2	Left side cover	12	Table 2
3	Paper feed roller	13	Right side cover
4	Paper guide	14	Paper feed table
5	Auxiliary feed table	15	Table 1 socket
6	Paper discharge roller	16	Table 2 socket
7	Paper discharge table	17	Power source switch
8	Stopper fine adjustment knob	18	Inlet
9	Table 1	19	Circuit breaker
10	Control panel		



## (4) Designation and Functions of Operation Panel

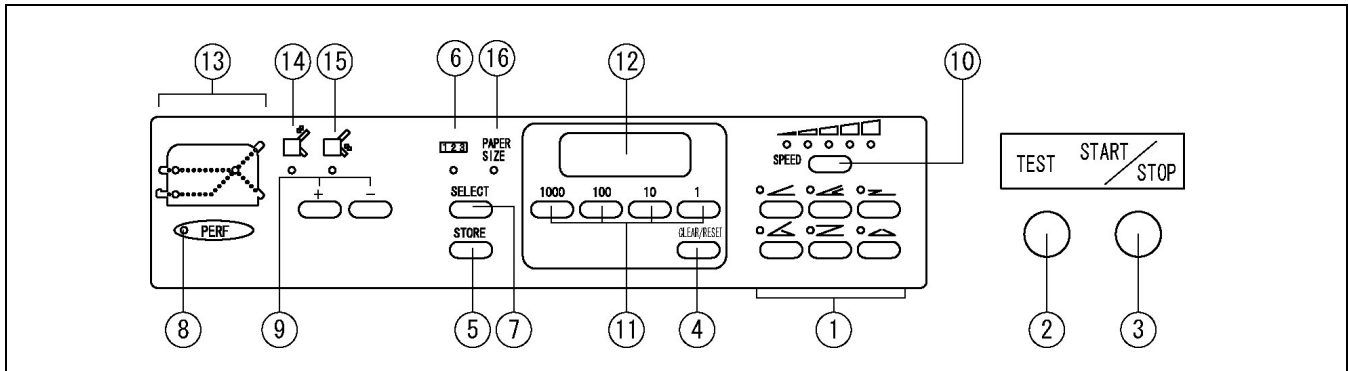

No.	Designation/Indication	Function
1	Fold type key	Six folding types can be input and stored.
2	Test key	Test folding of two sheets is performed.
3	Start/Stop key	Operation starts and if pushed again, the machine stops.
4	Clear/Reset key	Clearing the indication of the counter / resetting an error.
5	Store key	Fold position after adjustment is stored.
6	Counter input mode lamp	It is on when batch counting is indicated on the counter.
7	Select key	Used for selecting the indication of the counter, the position of the stopper stud of Table 1 and 2 and paper length.
8	Perforation mode lamp	It is on when the optional sewing unit is installed.
9	+/- key	Used for adjusting the position of the stopper of Table 1 and 2 and paper length
10	Speed adjust key	Used for adjusting the speed.
11	Numerical key	Used for inputting the batch count and the length of non-standard-size paper
12	Counter	The number of sheets, the position of the stopper pin of Table 1 and 2, paper size are indicated.
13	Check lamp	It is on when paper stock runs short, or indicates a Place where paper feed trouble occurs.
14	Table 1 stopper move mode lamp	It is on when the position of stopper of Table 1 is Adjusted.

15	Table 2 stopper move mode lamp	It is on when the position of stopper of Table 1 is adjusted.
16	Paper size paper size input mode lamp	It is on when paper size is indicated.

## (5) Counter Indication

### (A) Addition

As a sheet is folded, the number indicated on the counter increases by one.

Press the Select key and select the Counter Input Mode Lamp

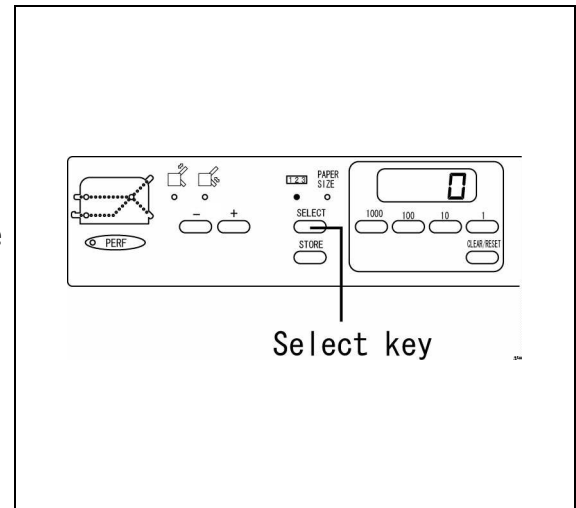

Press Clear/Reset key and reset the number to zero (0).

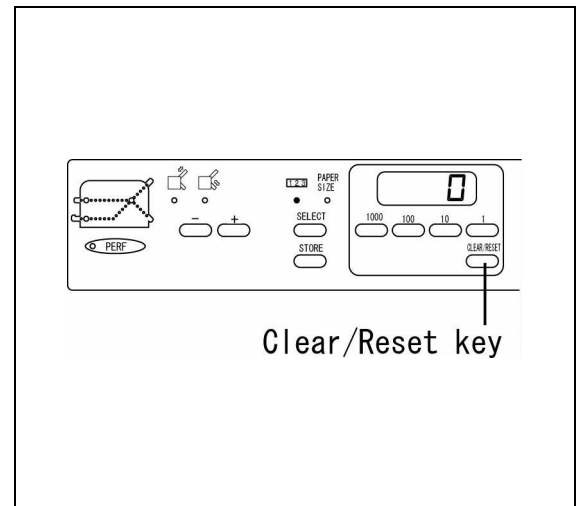



# (B) Batch Counting

As a sheet is folded, the number indicated on the counter decreases by one.

Press the Select key and select the Counter Input Mode Lamp.

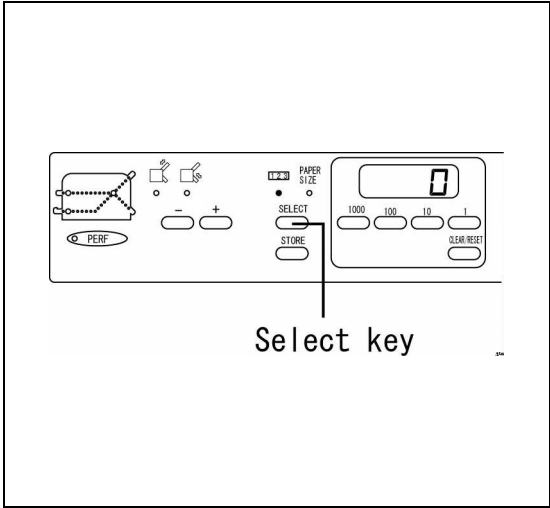

Input the desired number using the Numerical key. (20 is input in this case)  
The Batch Counting Mode Lamp will be on.

When the machine is started it will fold the desired number of documents and stop

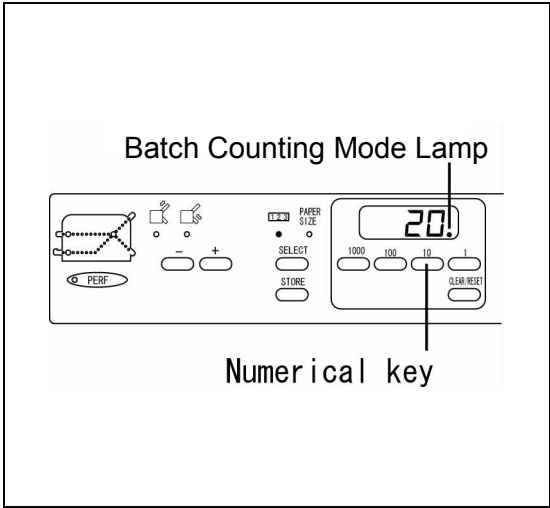

## (6)Preparation

Install Table 1 and 2.

Insert the front cut-away section of Table 1 onto the stud (1) of the machine and drop its rear cut-away section on the stud (2). Insert the plug into the connector (3).

**Caution:**

The connector will only go in one way,  
Insertion by force may cause trouble.

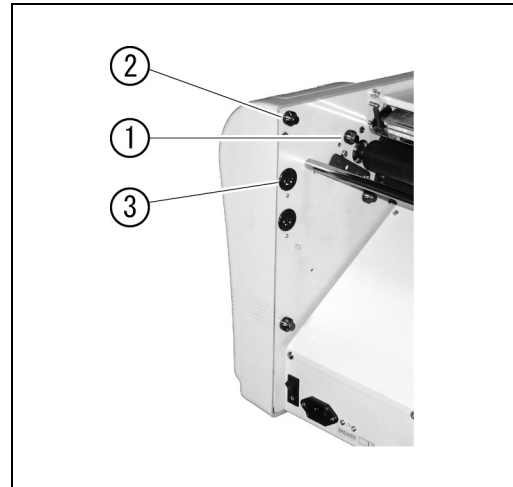

Insert the front cut-away section of Table 2 into the stud (4) of the machine and drop its rear cut-away section on the stud (5). Insert the plug into the connector (6).

**Caution:**

The connector will only go in one way,  
Insertion by force may cause trouble.

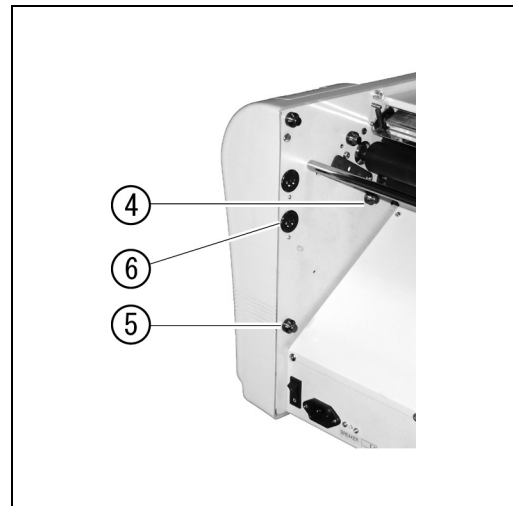

Pull the paper-stacking table out and set it while lifting the auxiliary table.

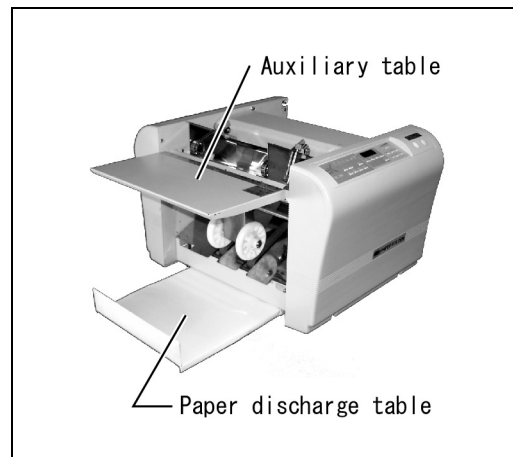

Insert the power cord into the outlet.

**Caution:**

Be sure to unwind cord before use.

Do not use any power cord other than provided as an accessory.

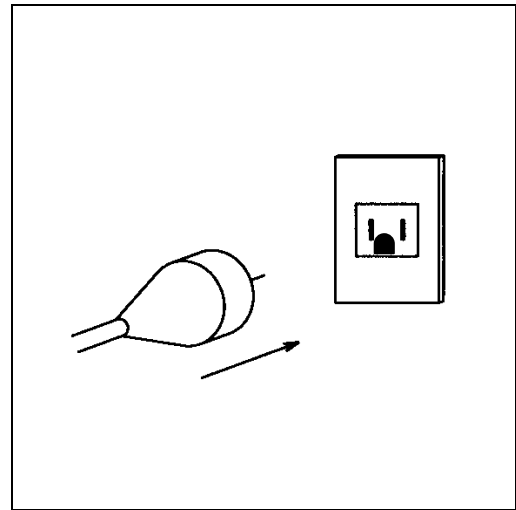

Insert the power cord into the inlet.  
When the power switch is on, the stoppers of Table 1 and 2 move to the home position.

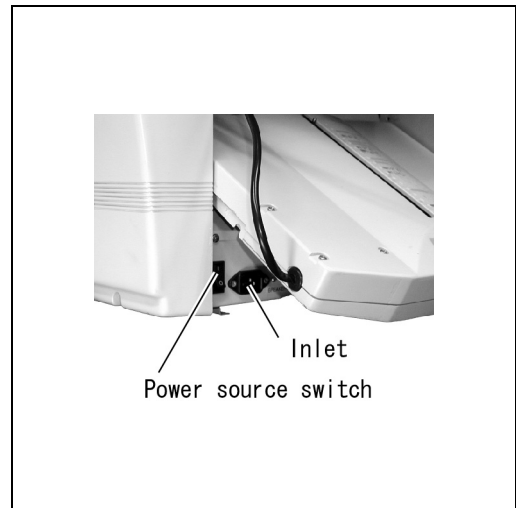

## (7) Operation

### (A) Standard folding of standard-size paper

#### **How to perform standard folding of standard-size paper:**

Flip power switch to on position.

Loosen the paper guide setscrew and set the paper guide to fit the width of the paper.

Neatly arrange paper and place it on the paper feed table with its printed side facing up (its printed side down in case of fold-out).

Make sure the paper guides contact the paper and tighten the setscrew.

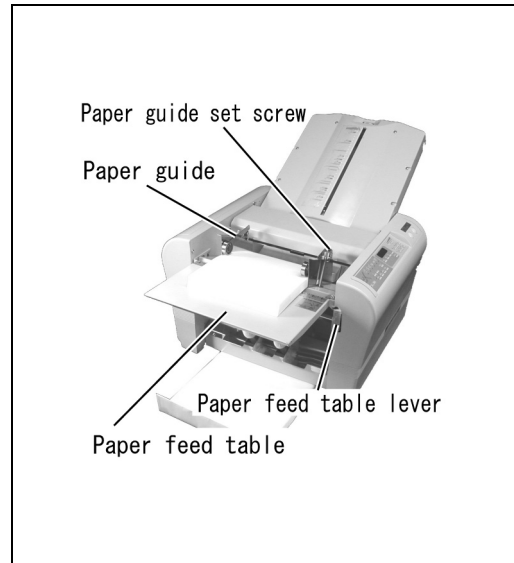

#### **Setting the paper discharge roller:**

The discharge roller should be moved to the proper position that suits the paper size.

#### **Note:**

Refer to "Roller position indication" label. If ejection is not performed properly set to a different position.

Example:

Set the roller to position one when using 8 1/2" x 11" paper.

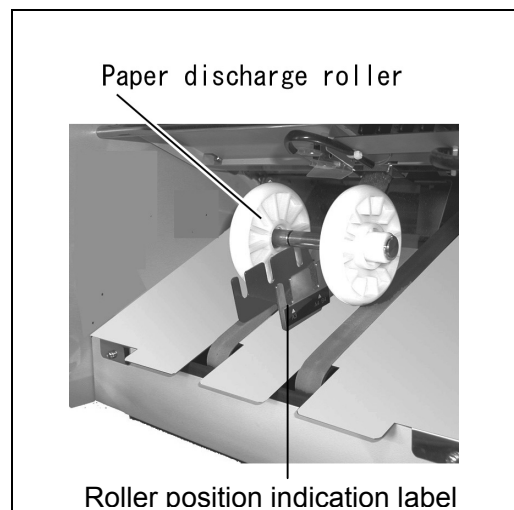

### Choosing a fold type:

One of the six folding types (Single, Gate, Letter, Zigzag, Double Parallel, Fold-out) can be chosen by pressing the desired fold type key.

Example:  
Single folding using C3 (Legal Size) Paper

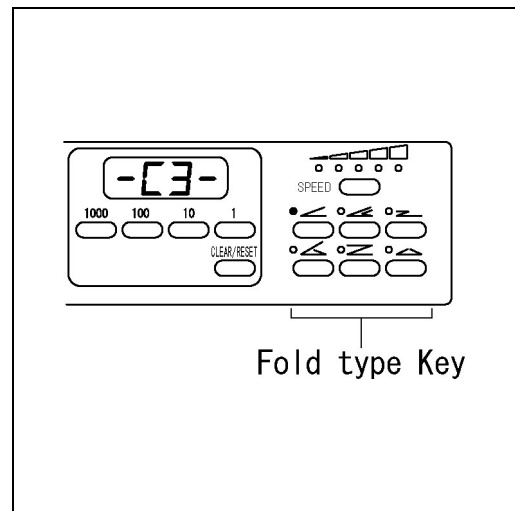

### Test folding:

If the Test key is pressed, two sheets will be folded while not affecting the indication of the counter.

Check the folding of the second sheet.

If a folded sheet is skewed, refer to the feed angle section on page 19, and 20.

#### Note:

If the stopper fine adjustment knob is moved, when the Test key is pressed, the machine will continue to fold. When the Start/Stop key is pressed, the machine will start to fold after the stopper is returned to the previous position.

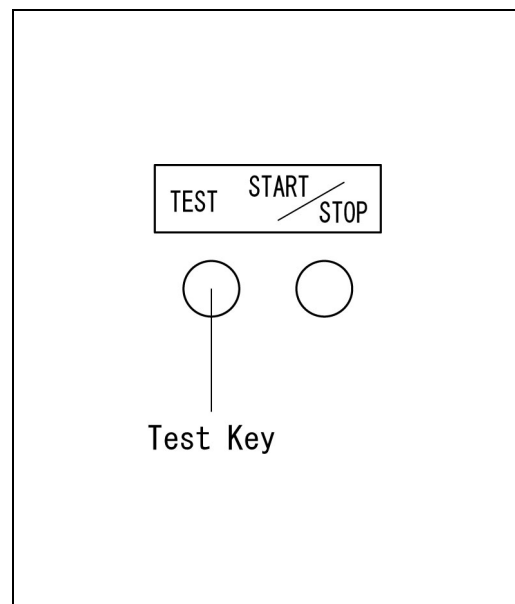

### Continuous folding:

When the Start/Stop key is pressed, the machine will continuously fold the paper.

When the Start/Stop key is pressed while the machine is in operation, the machine will stop the operation.

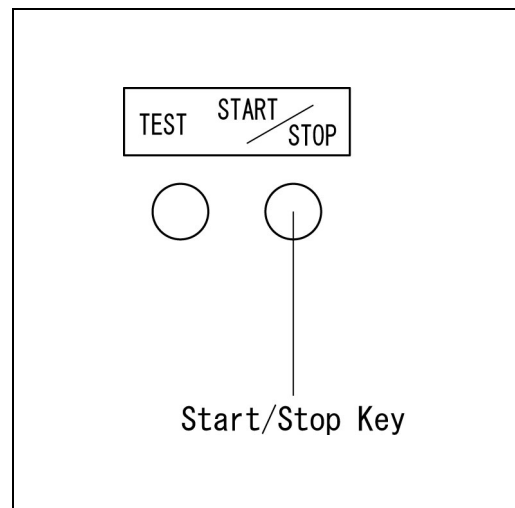

## (B) Manually Setting Standard Folding of Non-standard-size Paper

### Determine the Paper Length

Measure the paper length in inches.  
The arrow indicates the direction of paper Feeding

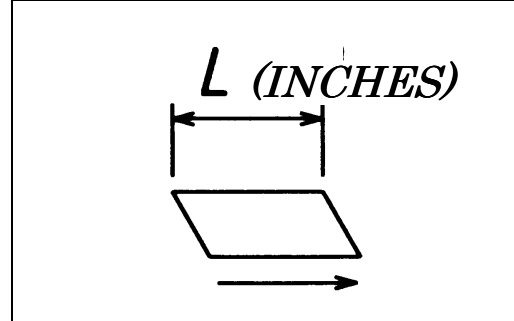

### Setting Table 1

Press the select key and select the Stopper Move mode of table 1. Press the + or - keys to move the stopper to a desirable position.

(The position of the stopper is indicated on the counter display.)

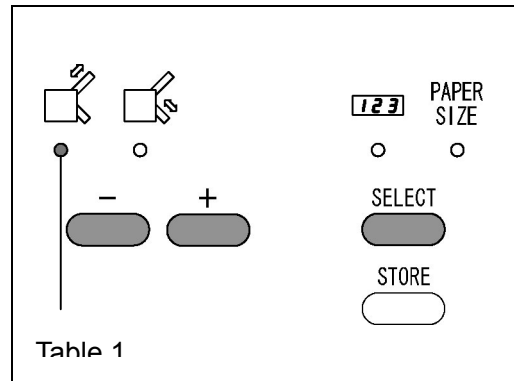

### Setting Table 2

Press the select key and select the Stopper Move mode of table 2. Press + or - keys to move the stopper to a desirable position.

(The position of the stopper is indicated on the counter display.)

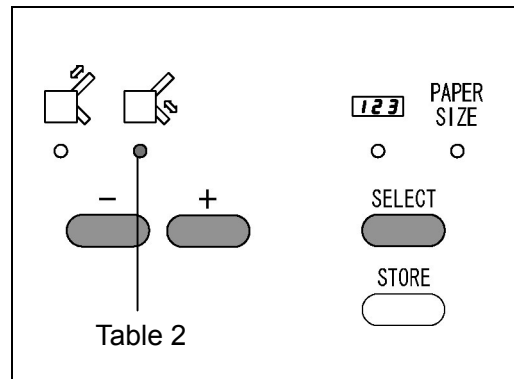

## Fold -Stopper Position Chart

**Note:**

Positioning of the paper length and the stoppers of Table 1 and 2

(Example) In the case of performing the zigzag fold using sheets of paper 12" in length:

Table 1 = 12" x (2 / 3) = 8"

Table 2 = 12" x (1 / 3) = 4"

	Table 1	Table 2
SINGLE	Original position	1/2
GATE	1/4	1/2
LETTER	1/3	1/3
ZIGZAG	2/3	1/3
DOUBLE	1/2	1/4
PARALLEL FOLD-OUT	3/4	1/4

**Test folding:**

If the Test key is pressed, two sheets will be folded while not affecting the indication of the counter.

Check the folding alignment with the second sheet folded.

If the fold is skewed, refer to the skew adjustment section on page 19 and 20.

**Caution:**

If the fold stopper fine adjustment knob is moved, when the Test key is pressed, the machine will continue to fold. When the Start/Stop key is pressed, the machine will start to fold after the stopper is returned to the previous position.

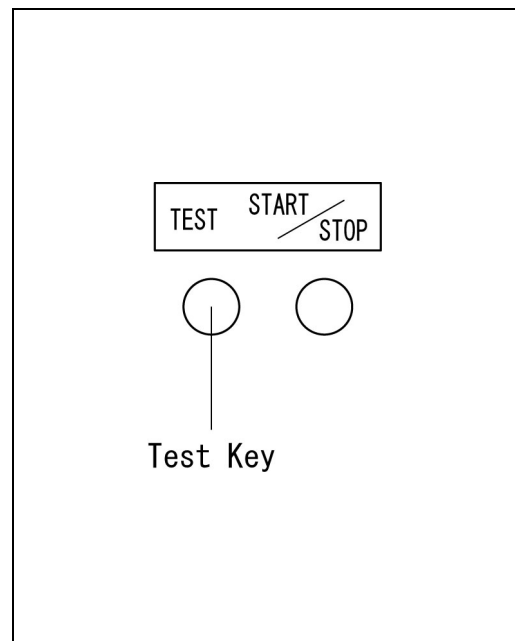

**Setting the paper discharge roller:**

The discharge roller should be moved to the proper position that suits the paper size.

**Note:**

Refer to "Roller position indication" label. If ejection is not performed properly, set to a different position.

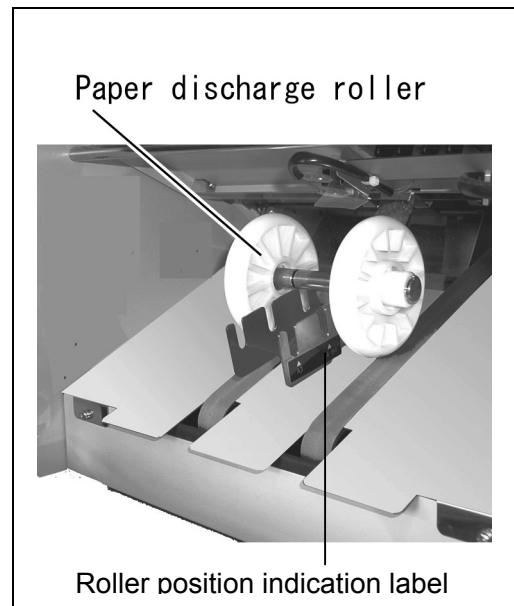

**Continuous folding:**

When the Start/Stop key is pressed, the machine will continuously fold the paper.

When the Start/Stop key is pressed while the machine is in operation, the machine will stop the operation.

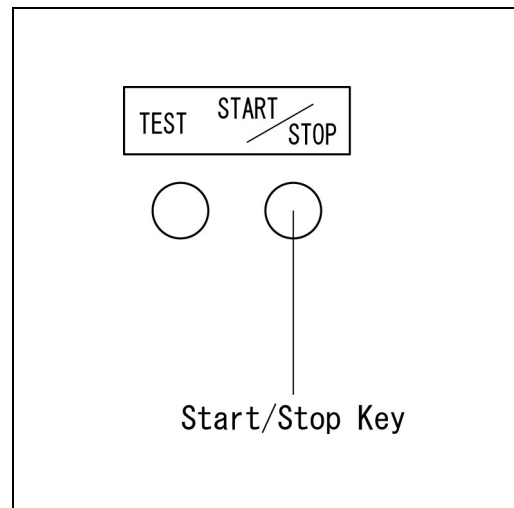



## (C) Cross Folding

Cross folding refers to performing the double parallel, letter, or other types of folds for the sheets of paper folded using the single fold method.

Example:  
11"x 17" folded in half and then letter folded to fit into a standard # 10 envelope.

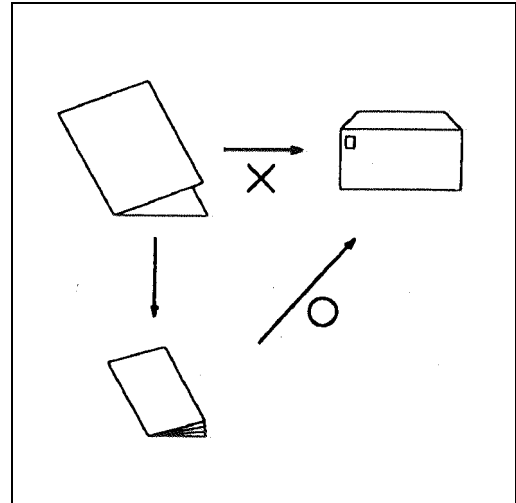

### Note:

The maximum weight of paper that can be used for cross folding is 28 #.

This requirement, however, varies according to the following conditions:

Paper type; Paper size;  
Whether grains run lengthways or sideways;  
Temperature and relative humidity;  
Printing condition.

The folding position may be displaced to a greater extent than when the paper is folded using a regular fold method, or a corner of the folded paper may be folded inside as indicated in the figure. These, however, do not mean that the machine has broken down.

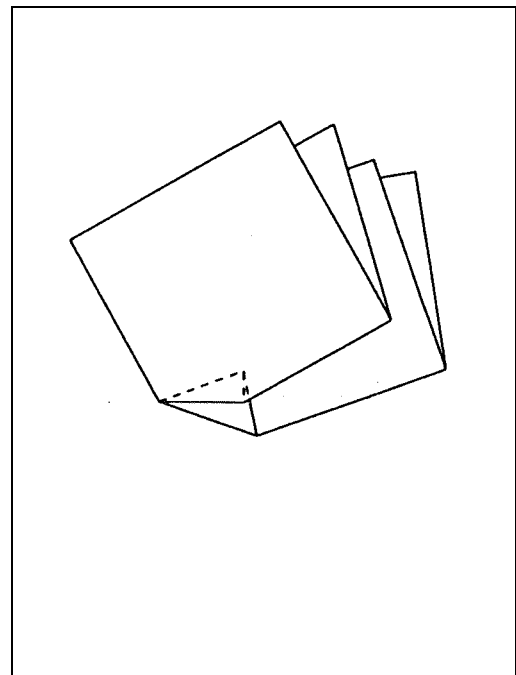

### Note:

Press the crease hard using the hand. Do not stack too many sheets of paper on the paper feed table.

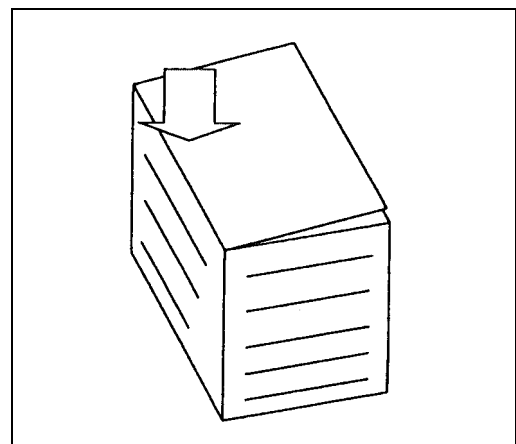

## (8) Adjustments

### (A) Feed Angle /Skew Adjustments

If the folding position is slanted because the edges of the paper are slanted or for other reasons, it can be adjusted using the feed angle adjustment knob.

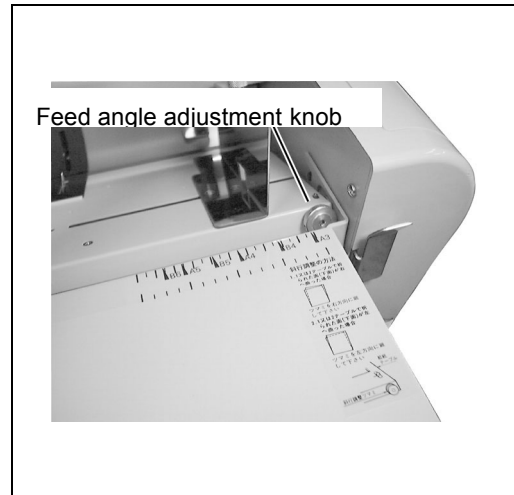

### (B) Fine Adjustment

Move the stopper using the stopper fine adjustment knob.

#### **Caution:**

In case the stopper fine adjustment knob is moved, when the Test key is pressed, the machine will continue to fold. When the Start/Stop key is pressed, the machine will start to fold after the stopper is returned to the previous position

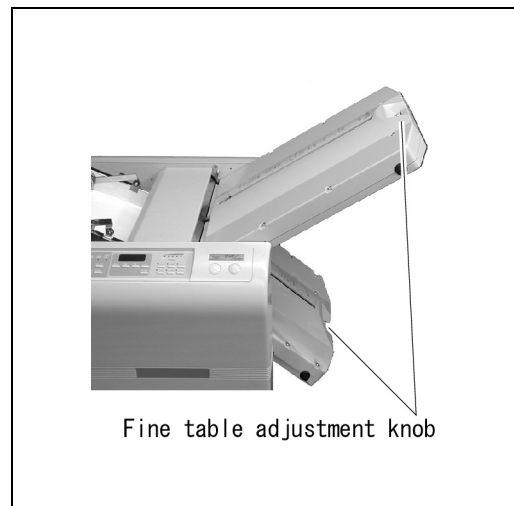

#### **Note:**

When the stopper is moved more than a few mm, it will be convenient to use the +/-key.

#### **Adjusting Table 1**

Press the Select key and select the Table 1 stopper move mode. Next press the +/- key and move the stopper to the desired position.

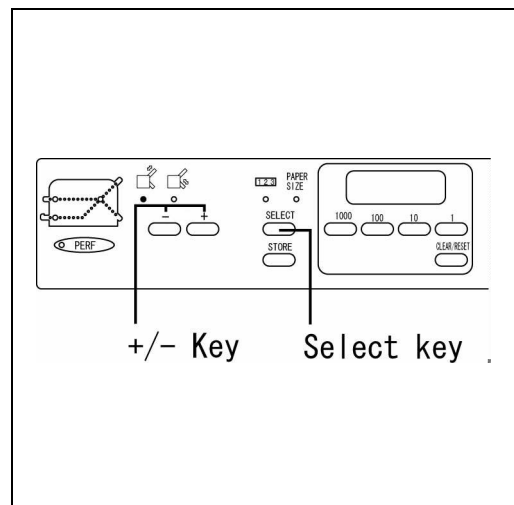





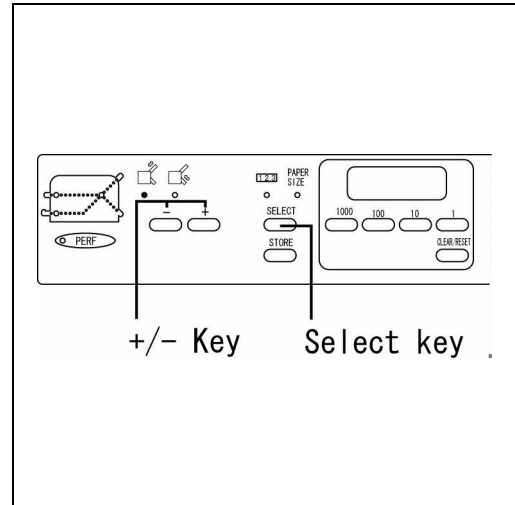









## Adjusting Table 2

Press the Select key and select the Table 2 stopper move mode. Next press the +/- key and move the stopper to the desired position.





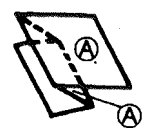





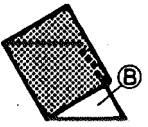

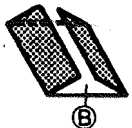

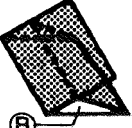

## Fine Adjustments for Table 1

Fold type		Plane (A)	Direction to turn the Table 1 fine adjustment knob
Single fold	Table 1 is not used		
Gate fold		Long	
		Short	
Letter fold		Long	
		Short	
Zigzag fold		Long	

		Short	
Double parallel fold		Long	
		Short	
Fold-out		Long	
		Short	

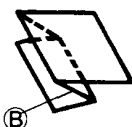
## Fine Adjustments for Table 2

Fold type		Plane (B)	Direction to turn the Table 2 fine adjustment knob
Single fold		Long	
		Short	
Gate fold		Long	
		Short	
Letter fold		Long	
		Short	
Zigzag fold		Long	
		Short	
Double parallel fold		Long	
		Short	
Fold-out		Long	
		Short	

# (9) Storing Custom Folds in Memory

## (A) Memory Storage

Custom fold types can be stored into the fold type keys in replacement of the factory set fold types.

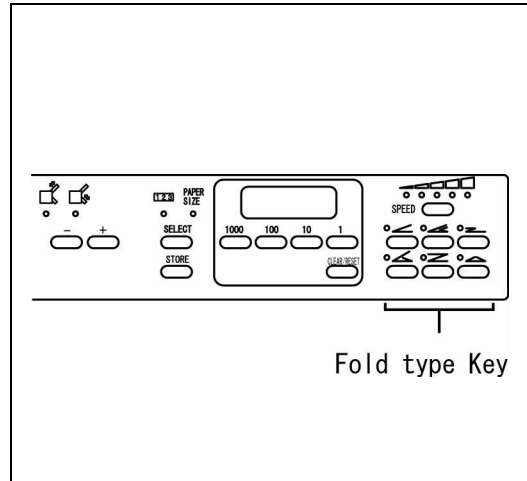

### Adjust Table 1 and 2 for desired fold

#### Setting Table 1

Press the select key and select the Stopper Move mode of table 1. Press the + or - keys to move the stopper to a desirable position.

(The position of the stopper is indicated on the counter display.)

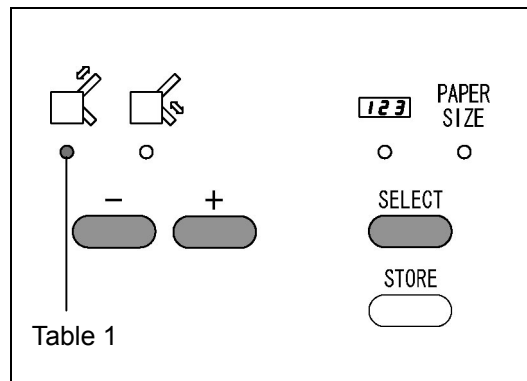

#### Setting Table 2

Press the select key and select the Stopper Move mode of table 2. Press + or - keys to move the stopper to a desirable position.

(The position of the stopper is indicated on the counter display.)

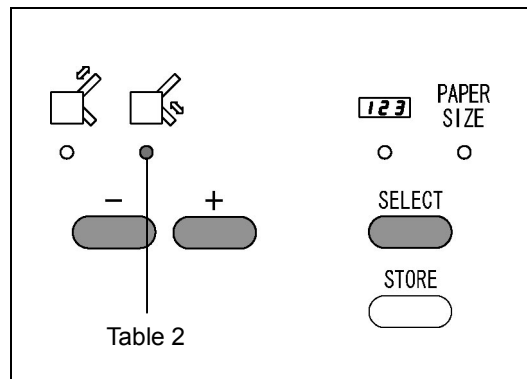

## Storing the fold into Memory

Select the fold type key the storage will be input. Press and hold the Store key, release immediately when the alarm rings once.

The lamp of the fold type key selected will be blinking.

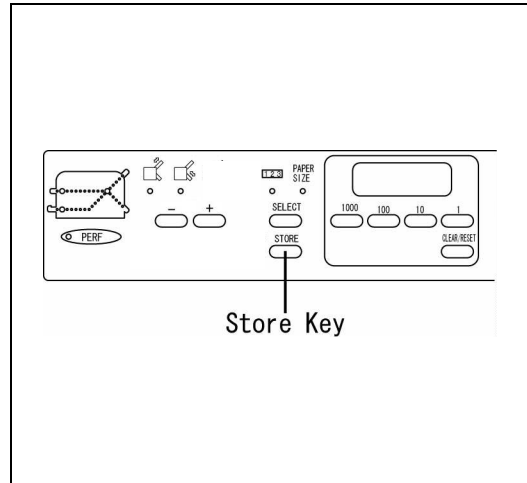

## (B) Cancellation of Memory

### Canceling the storage of a custom fold:

#### Note:

If the memory is cancelled, the standard type of fold set by the manufacturer can be performed.

Select the fold-key memory to be cancelled.

#### Note:

The lamp of the key for which the storage is made flashes.

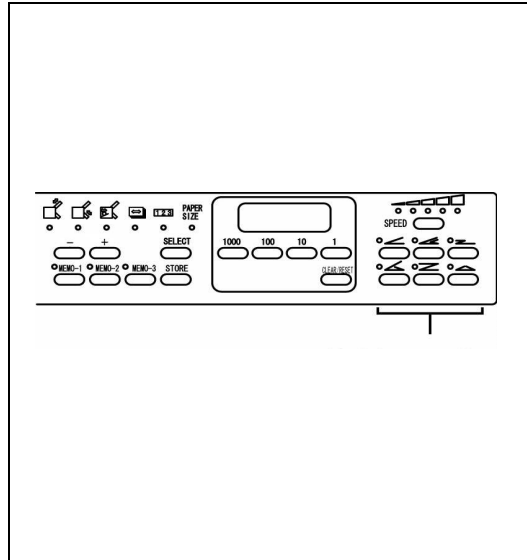



Press and hold the Clear/Reset key, release immediately when the alarm rings once.

The lamp for the fold key will stop blinking when the memory has been cancelled.

**Note:**

To return to the factory setting turn the machine "on" and "off", select a different fold type or press that key again.

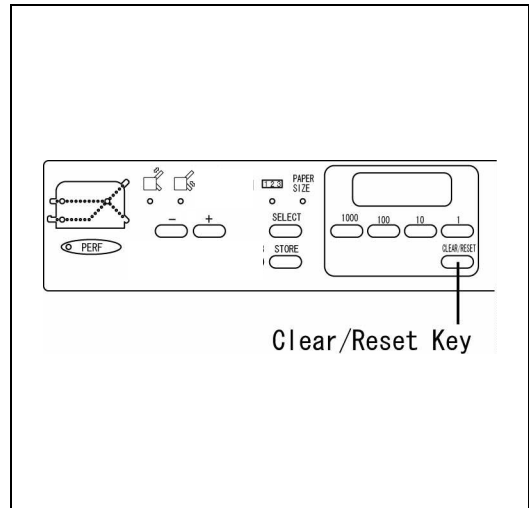

## (C) Cancellation of total storage

Canceling all the stored keys

Note: If the memory is cancelled, the standard type of fold set by the manufacture can be performed.

Press and hold the Clear/Reset key, release immediately when the alarm rings twice.

The lamps for the fold keys will go out when the memory has been cancelled.

