

FORMAX[®]

FD 3300
Tabletop Air Feed Folder

OPERATION MANUAL

Introduction

Thank you for purchasing a Formax product.

Be sure to read this manual and "Safety Guide A" supplied with this product before use. "Safety Guide A" contains information for correct and safe use of this product.

After reading, leave the manual and "Safety Guide A" at the site of use for easy reference whenever questions related to the product arise in the future.

Symbols

In this manual, several symbols are used to indicate important warnings. Please make sure to read instructions accompanied by these symbols. These symbols have the following meanings.



Describes instructions which must be followed in use.



Be sure to read the instructions to avoid problems due to incorrect operations.



Indicates supplementary or useful information.



Describes names of related items and supplementary instructions.

Trademark

The product name and company name used in this manual are trademarks or registered trademarks of the respective companies.

Copyrights

Reproduction or reprinting of this document in part or in whole without permission is prohibited.

Safety Precautions

Power supply

- Make sure the power supply used is always within the following range.
Power supply : 100 to 240 V AC, 50/60 Hz
- When you power other appliances from the same AC outlet, make sure that the combined power consumption does not exceed the power supply capacity.
Rated power: 190 W
Rated current: 1.9 to 0.8 A

Operating environment

Operate this unit in the following environment.

- where the temperature range is between 5 and 35°C/41 and 95°F (–10 to 50°C/14 to 122°F in storage)
- where the humidity range is between 20 and 80% RH (10 to 90% RH in storage, however no condensation)
- which is not subject to direct sunlight
- where the outside light does not exceed 1,500 lx
- which is subject to little or no vibration
- where the unit is kept away from air-borne salt
- where the unit is kept away from harmful chemicals
- where the unit is not exposed to water

WARNING/CAUTION labels

- ! "WARNING" and "CAUTION" labels are pasted on the machine to ensure user safety.
 - Do not remove or change them.
- When the labels become dirty or are lost, be sure to contact your dealer for a new one.

For EU

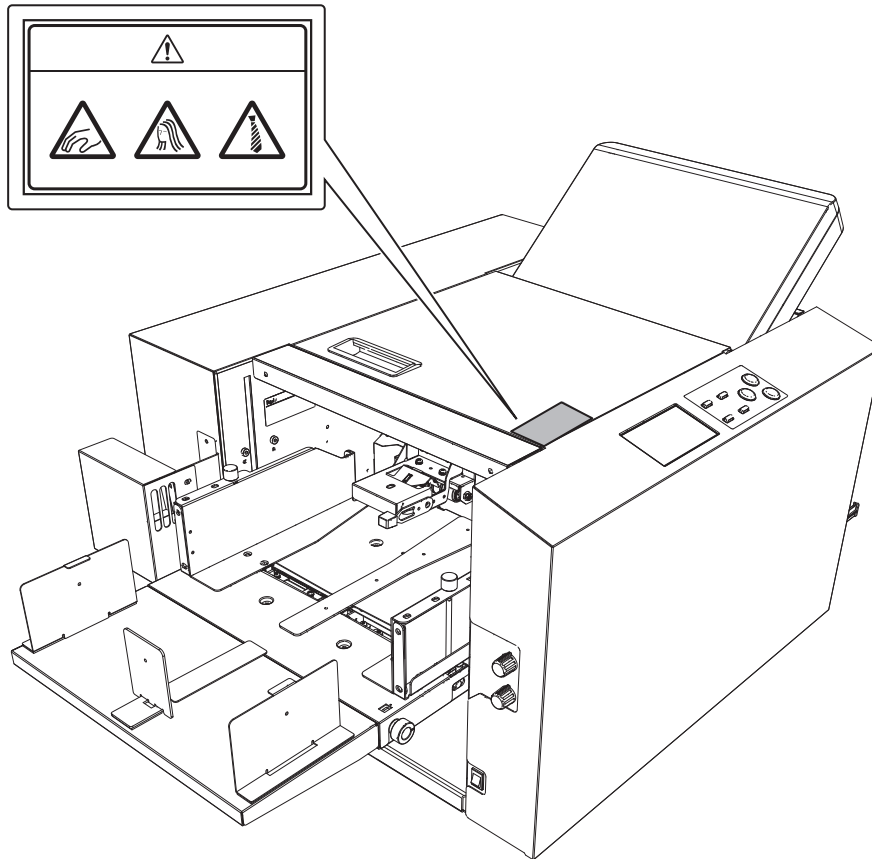

For North America

	CAUTION Keep away from moving parts. It could cause injury.
	ATTENTION Ne pas toucher les pièces mobiles. Vous risqueriez de vous blesser.

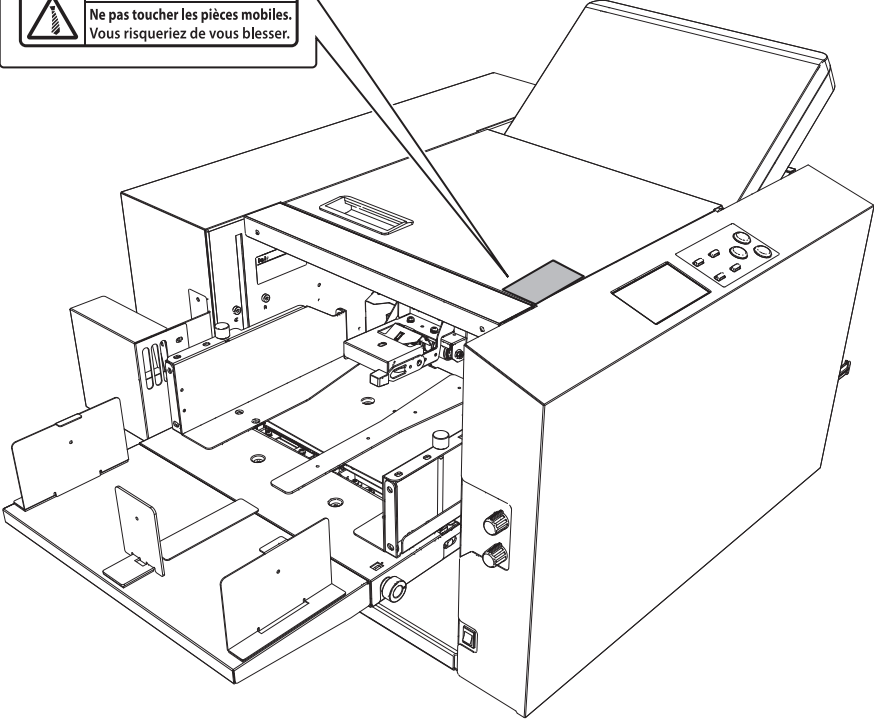

Memo

Safety Precautions	i
Power supply	i
Operating environment	i
WARNING/CAUTION labels	ii

Chapter 1 Before Operation

1. Features	3
2. Names and Functions of Components	4
2-1. External parts	4
2-2. Internal parts (paper feed section)	5
2-3. Internal parts (top cover section)	6
2-4. Internal parts (paper ejecting section)	7
2-5. Accessories	8
3. Names of Control Panel	9
4. LCD Touch Panel	10
5. Screen Configuration	10
5-1. [Ready] screen/[Processing] screen	10
5-2. [Basic Settings] screen	15
5-3. [Standard Size] select screen	15
5-4. [Paper Length] input screen (non-standard paper)	16
5-5. [Folding Mode] select screen	16
5-6. [No. of Sheet] input screen	17
5-7. [Fold Position] screen	18
5-8. [Stacker Roller] screen	19
5-9. [Custom Fold] screen	20
5-10. Folding A/Folding B input screen	23
5-11. Function Setting screen	24
5-12. Classification of buzzer sounds	26
6. Paper Types and Sizes	26
Paper that cannot be used with this machine	26
7. Handling Paper	27
7-1. Paper used	27
7-2. Precautions on stacking paper	27
8. Workflow	28

Chapter 2 Basic Operation

1. Turning On/Off Power	29
1-1. Installing power cord	29
1-2. Turning on power	29
1-3. Turning off power	29
2. Stacking the Paper	30

2-1. Before stacking paper	30
2-2. Stacking paper	30

3. Standard Folding of Standard Paper.....	33
4. Storage of Machine	40

Chapter 3 Advanced Operation

1. Correcting Folding Misalignment.....	42
1-1. Adjusting folding misalignment in right and left direction	42
1-2. Adjusting folding misalignment in up and down direction	44
1-3. Deformed folding	46
2. Standard Folding of Non-Standard Paper	46
3. Custom Folding.....	47
3-1. Operation	48
3-2. Editing saved data	49
3-3. Using saved data	49
3-4. Locking saved data	50
3-5. Deleting saved data	50
3-6. Directly saving folding value under processing	50
4. Cross Fold	51
4-1. Cross fold of standard paper	51
4-2. Cross fold of non-standard paper	54
4-3. Cross fold paper at desired folding position	54
5. Stacker Roller Adjustment.....	55
5-1. Changing stacker roller height	55
5-2. Adjusting stacker roller position	55
6. Stacking Folded Paper	57
7. Adjusting Spring Pressure.....	58
8. Function Settings	59
8-1. Thin paper mode	59
8-2. Interval function	59
8-3. Double-feed detection	61
8-4. Detection	62
8-5. Paper feed interval time	63
8-6. Belt conveyance volume	63
8-7. Idling	64
8-8. Tray descend amount	65
8-9. Tone	66
8-10. LCD bright	66
8-11. Number of test sheets	67
8-12. Language	67

8-13. Power saving	68
8-14. Alarm	69
8-15. Operation mode when turned on	70
8-16. Initial screen.....	71
8-17. Custom screen	72
8-18. mm/inch.....	73

Chapter 4

Maintaining the Machine

1. Cleaning folding roller and conveyance roller	74
2. Cleaning LCD.....	75
3. Cleaning belts	75
4. Cleaning sensors.....	76

Chapter 5

Trouble Guide

1. Error Code	79
1-1. Warning error	79
1-2. Motor error.....	80
1-3. Paper jam error	80
1-4. Other errors.....	81
1-5. Errors requiring service call	81
2. Paper Jam	82
2-1. Paper feed section.....	82
2-2. Folding plate.....	82
2-3. Folding roller	86
2-4. Ejecting section.....	87
3. Troubleshooting	87

Chapter 6

Appendix

1. Specifications.....	92
-------------------------------	-----------

Chapter 1 Before Operation

1. Features

- This machine is a desktop paper folder. Standard folding of standard paper can be easily controlled and operated from the control panel.
- This machine is designed to fold paper into six popular folding modes.

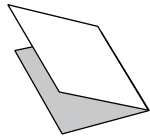

Single fold

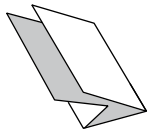

Double fold

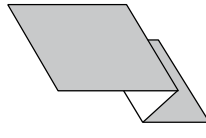

Irregular
accordion fold-out

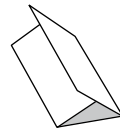

Letter fold

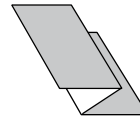

Accordion-fold

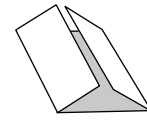

Gate fold

- Single folded paper can be folded further into other folding modes. (Cross fold)

2. Names and Functions of Components

2-1. External parts

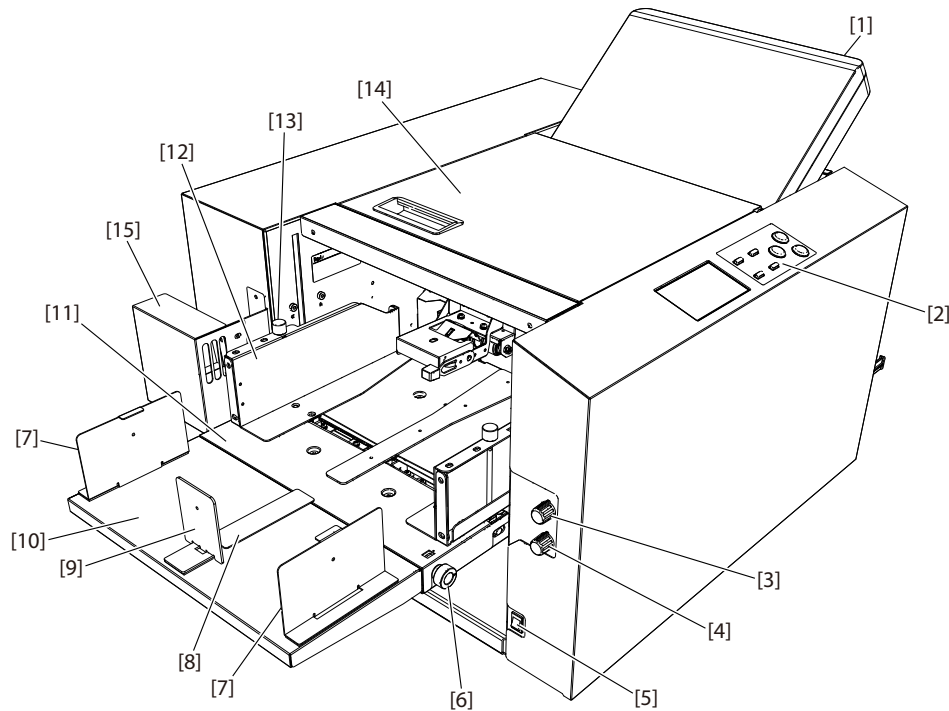

No.	Name	Function
[1]	Folding plate 1	Guide plate for deciding the paper folding position.
[2]	Control panel	Use this panel to enter information to operate the machine (p.9).
[3]	Separating air adjustment	For adjusting the separating air amount.
[4]	Separator adjustment	For adjusting the height of the separator.
[5]	Power switch	☞ "1. Turning On/Off Power" (p.29)
[6]	Skew correction knob	Use this knob to correct the folding misalignment in both directions.
[7]	Side guide unit	Use this guide to hold both sides of paper when stacking long size paper.
[8]	Plate unit	Use this unit to send separating air toward the rear end of paper when stacking long sheets of paper.
[9]	Trail edge guide unit	Holds the back edge of paper stacked on the paper feed tray.
[10]	Auxiliary paper feed tray	For stacking paper on the paper feed tray in a stable condition. Do not lean on the auxiliary paper feed tray or hold on to it to lift up the machine.
[11]	Paper feed tray	For stacking the paper to be folded. Do not lean on the paper feed tray or hold on to it to lift up the machine.
[12]	Paper feed guide	Holds both sides of paper when the paper is stacked on the paper feed tray.
[13]	Guide fixing screw	For securing the paper feed guide.
[14]	Top cover	Safety cover to prevent the user from touching the moving parts.
[15]	Side air	Makes paper separation better and paper feeding smoother.

2-2. Internal parts (paper feed section)

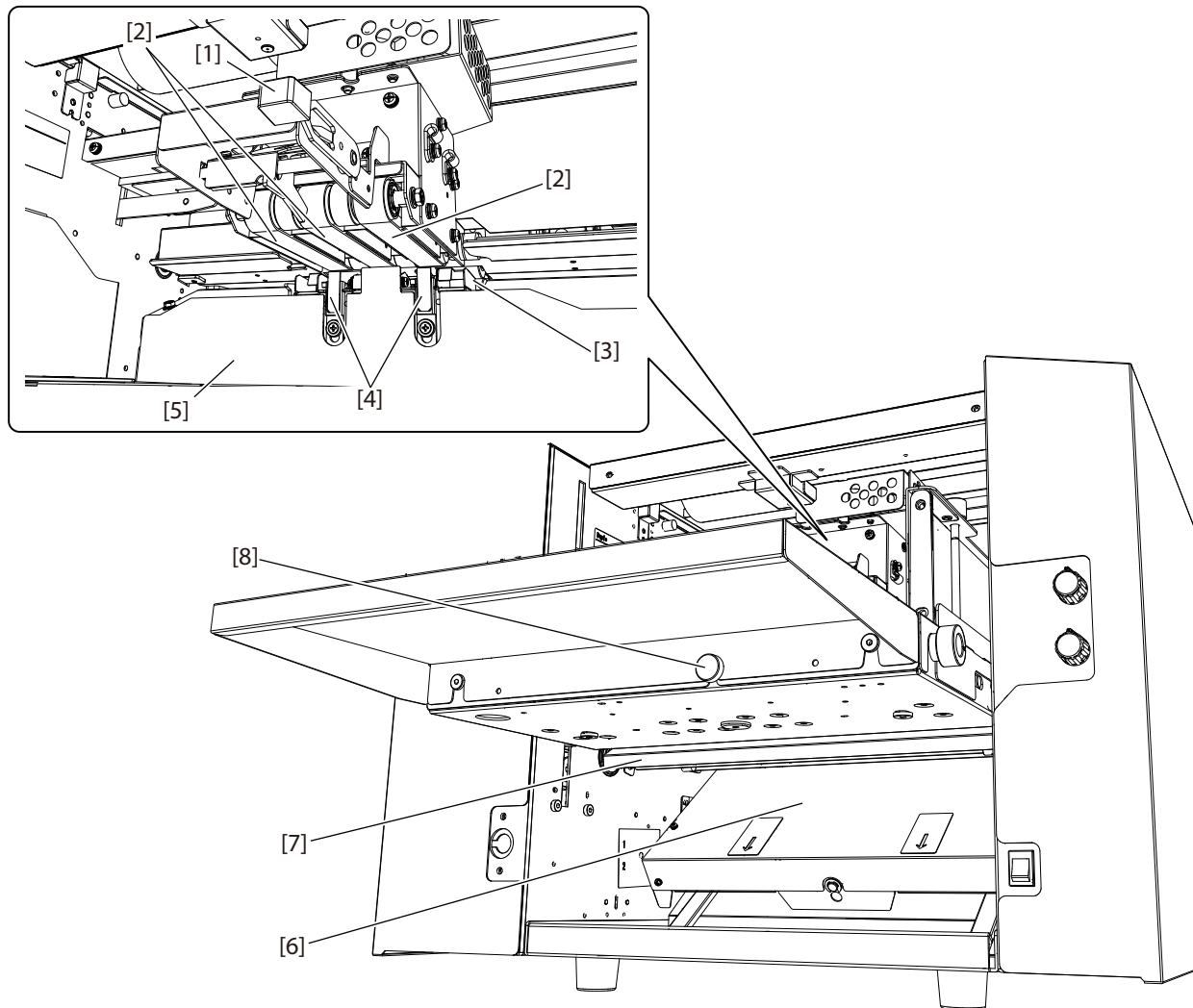

No.	Name	Function
[1]	Stack height sensor adjustment	For adjusting the distance between the paper and suction belt.
[2]	Suction belt	Sucks and conveys paper.
[3]	Separating-air duct	Blows out air for separating paper stacked on the paper feed tray.
[4]	Separator	Prevents double-feed.
[5]	Shutter	Adjusts the amount of separating air blown out. Use the separating air adjusting knob to adjust the amount.
[6]	Folding plate 2	Guide plate for deciding the paper folding position.
[7]	Safety lever	This lever prevents fingers from getting caught when the paper tray is lowered.
[8]	Knob screw	This screw secures the auxiliary paper feed tray in place.

2-3. Internal parts (top cover section)

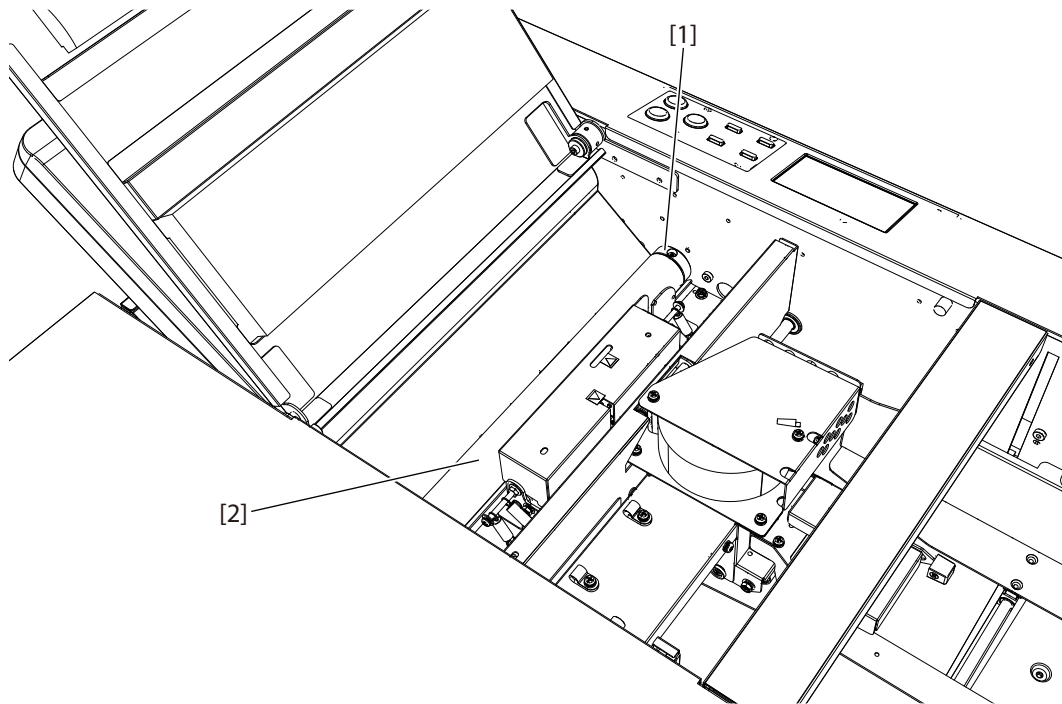

No.	Name	Function
[1]	Jam correction knob	For rotating the folding rollers when paper has jammed inside the unit or when cleaning the unit.
[2]	Folding roller	These rollers are used to fold paper. This machine is equipped with four rollers to make six types of folding.

2-4. Internal parts (paper ejecting section)

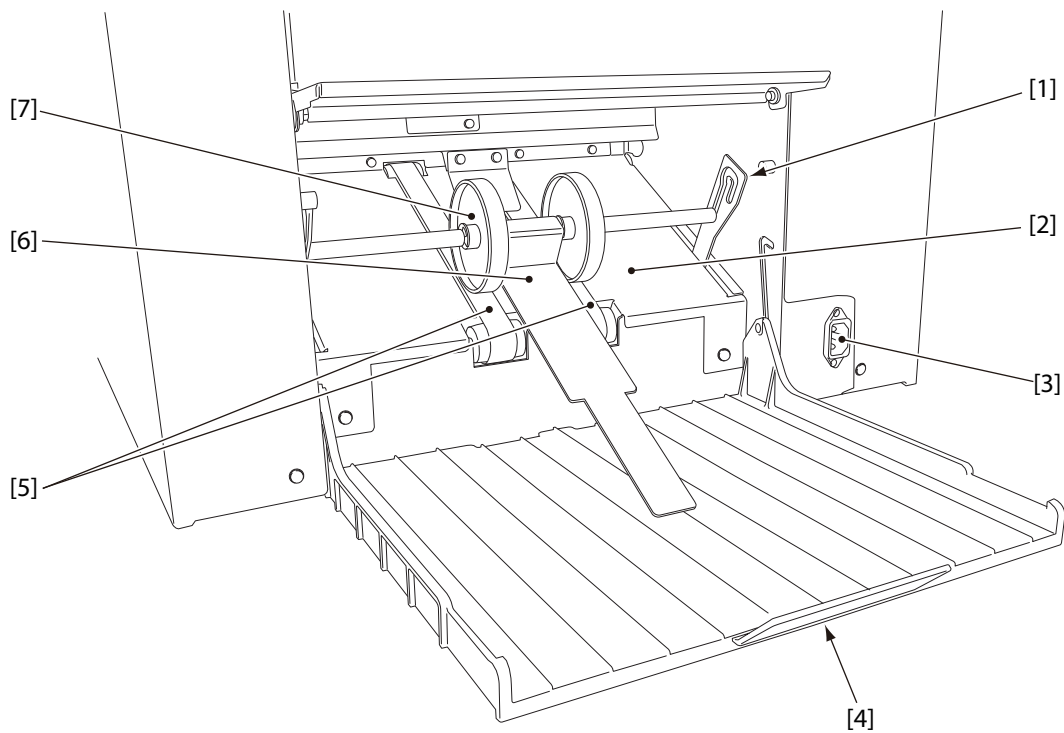

No.	Name	Function
[1]	Stacker roller lever	This is the lever that supports the stacker roller. The height of the roller can be adjusted.
[2]	Ejecting section	For receiving folded paper ejected out.
[3]	Power inlet	Connector for the power cord.
[4]	Paper receiving tray	For stacking ejected paper.
[5]	Stacker belt	For ejecting folded paper.
[6]	Auxiliary paper ejection guide	Holds the ejected paper from the top and prevent the mis-alignment of paper stacked on the paper feed tray.
[7]	Stacker roller	Holds down the ejected paper and supports conveyance of paper.



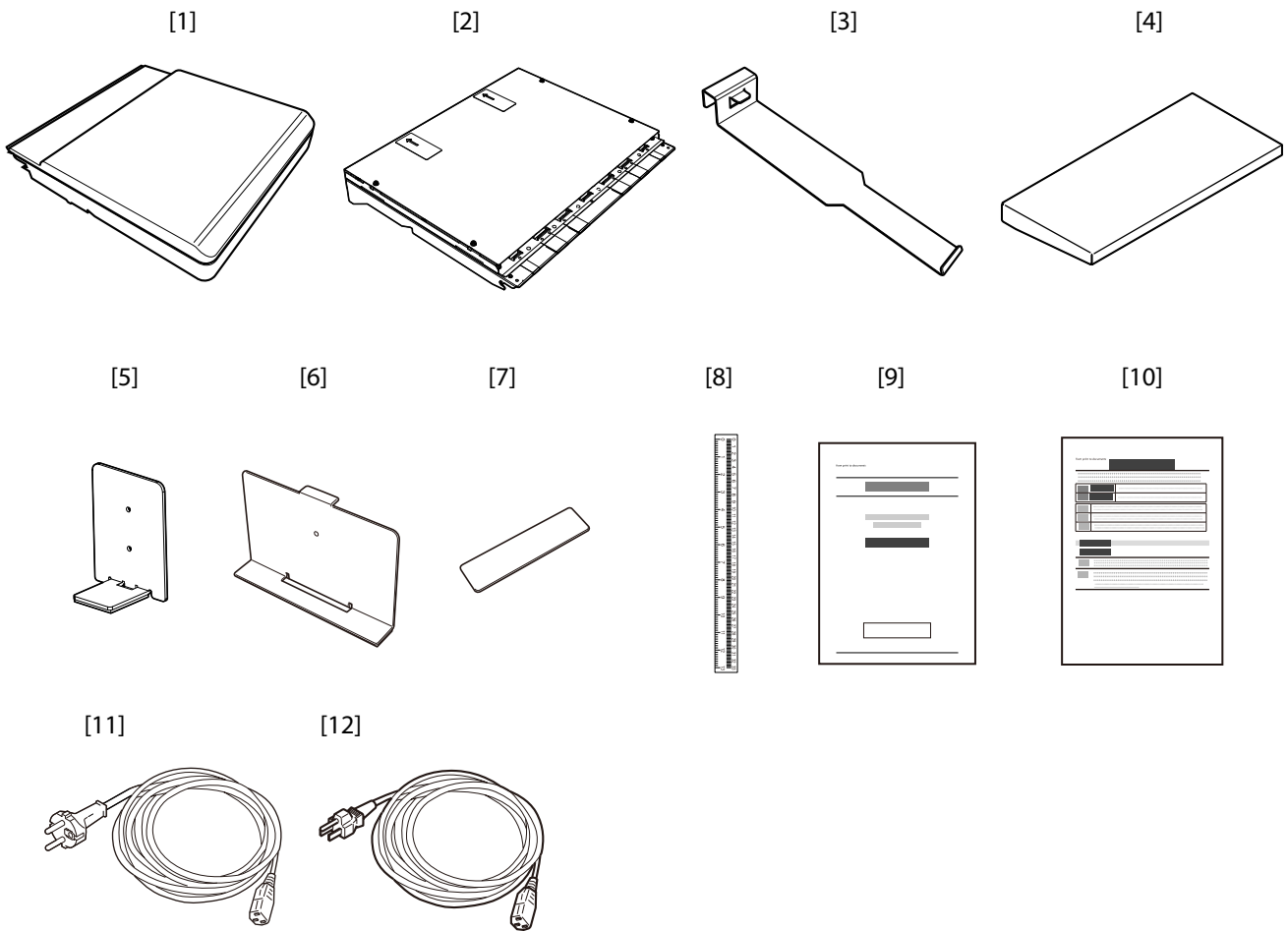

2-5. Accessories

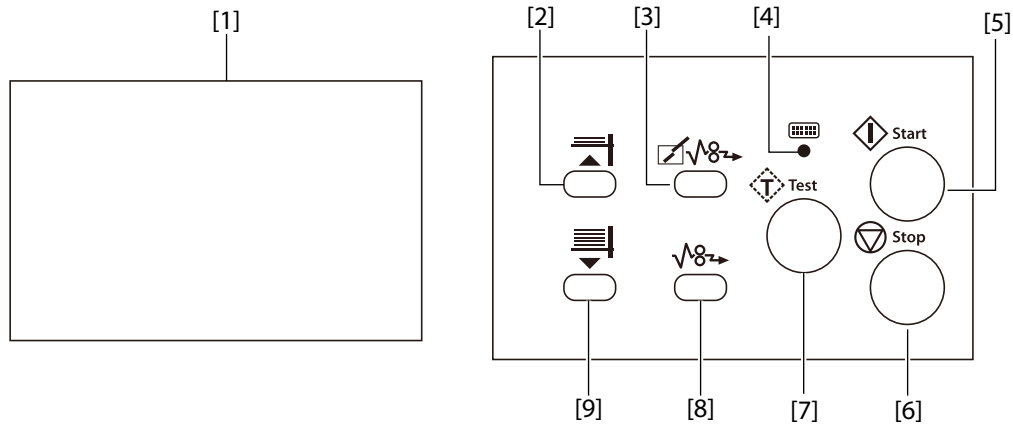

No.	Name	QTY	Function
[1]	Folding plate 1	1	
[2]	Folding plate 2	1	
[3]	Auxiliary paper ejection guide	1	
[4]	Auxiliary paper feed tray	1	
[5]	Trail edge guide unit	1	
[6]	Side guide unit	2	
[7]	Plate unit	1	
[8]	Scale label	1	
[9]	Instruction manual	1	This manual
[10]	Safety Guide A	1	Contains information for correct and safe use of this machine.
[11]	Power cord	1	For EU
[12]	Power cord	1	For North America

3. Names of Control Panel



No.	Name	Function
[1]	LCD touch panel	Displays the menus or error messages. Touch to operate.
[2]	Paper feed tray up key	While pressing the key, the paper feed tray goes up.
[3]	 (folding plate paper ejection) key	Press and hold to forcibly eject paper from inside the folding plate.
[4]	Lamp	When the machine is in the power saving mode, the lamp blinks slowly. When a message requiring service personnel is displayed, the lamp blinks faster.
[5]	 Start key	Press to start paper folding.
[6]	 Stop key	Press to stop paper folding.
[7]	 Test key	Press to test fold. Paper thickness can be stored by test folding.
[8]	 (paper ejection) key	Press and hold to forcibly eject paper from inside the machine.
[9]	Paper feed tray down key	While pressing the key, the paper feed tray goes down.

4. LCD Touch Panel

Cautions in using the touch panel

- The touch panel is designed to touch lightly with a finger or a pen (its tip radius is 0.8 or smaller). Do not press the panel strongly with a finger or push it with any sharp objects (such as a fingernail, ball-point pen, and pin).
- If you perform the following operations, the touch panel may not work even though you are touching it. Additionally, note that such operations may cause malfunction of the machine.
 - Operation with the tip of a nail
 - Operation with a foreign object placed on the touch panel
 - Operation with a protective sheet or sticker applied on the touch panel
 - Operation with the touch panel being wet
 - Operation with a finger wet with sweat or water

The following terms are used when explaining screen operation in this document.

Terms	Description
Touch	Lightly touching an item such as a key once with your finger.
Press and hold	Pressing an item such as a key for more than 1 second. The press-and-hold key is surrounded by a double frame ().

5. Screen Configuration

5-1. [Ready] screen/[Processing] screen

The following are the first screen displayed when the power is turned on, and the processing screen. When [Initial] is set to other than [Ready], the screen that you set is displayed.

[Ready] screen

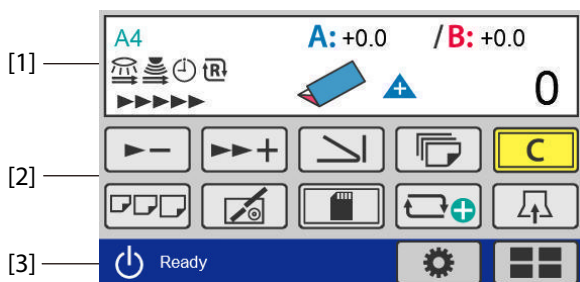

[Processing] screen

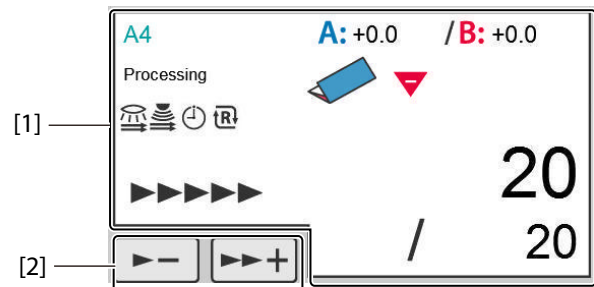

No.	Name	Function
[1]	Touch panel display	Icons and numerical values of the specified paper size, folding mode, etc. are displayed (p.11)
[2]	Touch panel operation section	Contains keys to change settings such as processing speed and folding mode. (p.13)
[3]	Page name	The name of the displayed page. The name is displayed on all the screens except the screen when an error occurs and the processing screen. [Ready] is displayed on the top screen.

5-1-1. Touch panel display

[Ready] screen

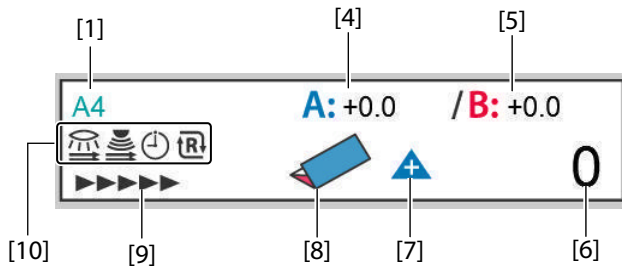

[Ready] screen (Custom fold)

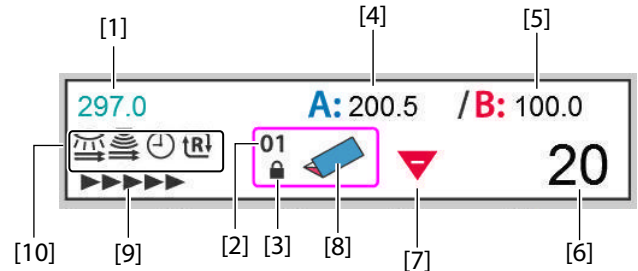



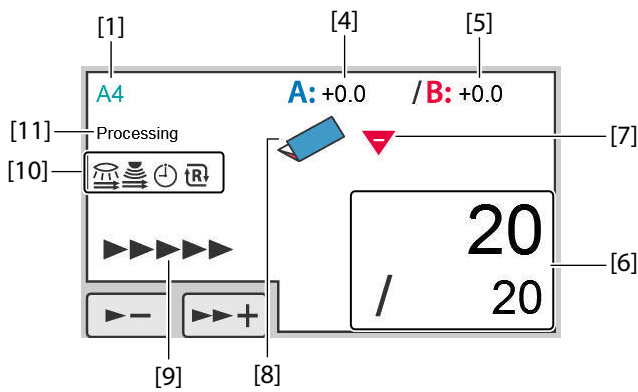



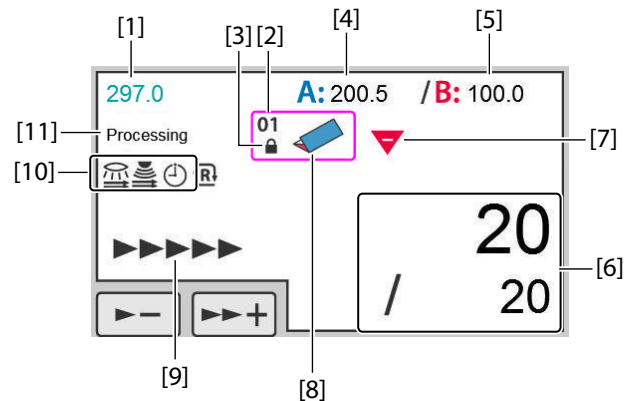









[Processing] screen



[Processing] screen (Custom fold)



No.	Name	Function
[1]	Paper size	Displays the detected standard paper size. A3/B4/A4/B5/A5/B6 (For EU) LGR (double letter)/LGL (legal)/LTR (letter)/STMT (statement)/INV (invoice) (For North America) When non-standard paper or custom folding is set, the paper length is displayed.
[2]	Memory number of custom folding	Displays the memory number currently used. When data is newly created but not saved, [00] is displayed. Available memory number: 01 to 30
[3]	Memory lock	Displayed when saved custom folding data is locked.
[4]	Folding plate A position adjustment	Displays the position adjustment value of the folding plate A. When in custom folding or stopper fixed mode, folding dimension A is displayed. Setting range: -5.0 to +5.0 mm/ -0.197 to +0.197 inch
[5]	Folding plate B position adjustment	Displays the position adjustment value of the folding plate B. When in custom folding or stopper fixed mode, folding dimension B is displayed. Setting range: -5.0 to +5.0 mm/ -0.197 to +0.197 inch
[6]	Counter	Displays current counter. Setting range: 0 to 99999 (sheets)

No.	Name	Function
[7]	Count mode	Displays counter mode (addition or subtraction).  Count up  Count down
[8]	Folding mode	Displays the folding mode currently set. When in custom folding or stopper fixed mode, displays a rough shape of the folding form.
[9]	Processing speed	Displays processing speed currently set. The processing speed is not displayed during [Ejecting Paper]. Setting range: 1- to 7 (speed)  (1-)  (1)  (2)  (3)  (4)  (5)  (6)  (7)
[10]	Special function display	Displays special functions currently set.  Double-feed detection is set. (optical sensor) State where the test folding is not performed.  Double-feed detection is set. (optical sensor) State where the test folding is performed.  Double-feed detection is set. (ultrasonic sensor)  [Interval] on  [Last Fold] on  [Stopper Fixed] on  [Belt Convey Vol] [Large]
[11]	Processing display	Displays the current machine status. Testing Processing Idling Ejecting Paper

5-1-2. Touch panel operation section



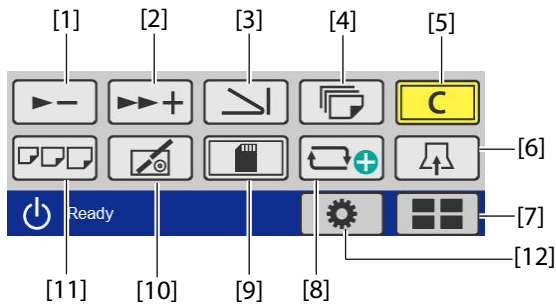



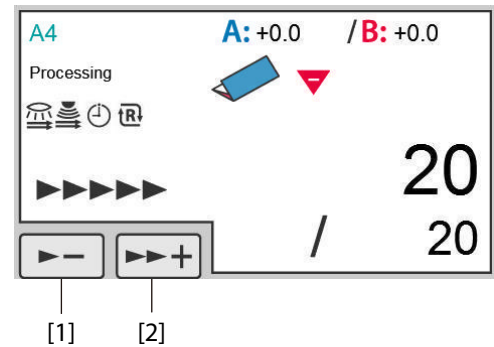

[Ready] screen



[Processing] screen





No.	Name	Function
[1]	(Processing speed down) key	The processing speed is slowed each time the key is touched. When processing speed is set to "1-", the key is grayed out and cannot be operated. Adjustable range: 1- to 7
[2]	(Processing speed up) key	The processing speed is sped up each time the key is touched. When processing speed is set to [7], the key is grayed out and cannot be operated. Adjustable range: 1- to 7
[3]	(Folding mode selection) key	When the key is touched, the [Folding Mode] screen is displayed. When the machine is set in custom folding mode, you can switch the folding mode to standard folding of non-standard paper by using this key.
[4]	(No. of sheet setting) key	The [No. of Sheet] screen is displayed when the key is touched.
[5]	(Clear) key	Press and hold to clear the counter. When a numerical value is entered, the value is set to the initial value.
[6]	(Air adjustment) key	Touching the key displays the [Air Adjust] screen.
[7]	(Basic settings) key/ (Function settings) key	When the machine is set to the mode other than the stopper fixed mode, this icon is displayed. The [Basic Settings] screen is displayed when the key is touched. Select either standard folding, standard folding for non-standard size, or custom folding. When the machine is set to the stopper fixed mode, this icon is displayed. The [Function Settings] screen is displayed when the key is touched. Make settings for a detection function such as double-feed and paper existence, feed interval and on/off of the buzzer.
[8]	(Custom folding)	The [Paper Length] input screen of [Custom Fold] is displayed. However, it is not displayed when the stopper fixed mode is selected.
[9]	(Save) key	Settings can be saved such as position adjustment of standard fold, position of stacker roller, new non-standard paper setting and folding setting of custom fold. However, when adjustment values are not changed, the key is grayed out and cannot be operated. It is not displayed when stopper fixed mode is selected.

No.	Name	Function
[10]	 (Adjustment) key	Touching the key displays the [Fold Position] screen. Locked custom fold and stopper fixed mode can also be adjusted
[11]	 (Paper size) key	Touching the key displays the screen to select a paper size. When the standard folding (with paper size detection set to off) is selected, the [Standard Size] screen is displayed. When the standard folding or non-standard paper is selected, the [Paper Length] screen is displayed.
[12]	 (Custom screen) key	Displays icons set in the custom screen. The set screen is displayed when the key is touched. However, it is not displayed when stopper fixed mode is selected. <ul style="list-style-type: none">  (Standard folding) The [Folding Mode] screen of [Standard Fold] is displayed. However, when automatic paper size detection is turned off, the [Standard Size] screen is displayed.  (Standard folding of non-standard paper). The [Paper Length] input screen of [STD Fold for Non-STD Size] is displayed.  (Custom folding) The saved data selection screen of [Custom Fold] is displayed.  (Function settings) The [Function Settings] screen is displayed.  (Language setting) The [Language] setting screen is displayed, and you can change the language displayed on the touch panel. When [Language] is set on the custom screen, the custom key is displayed in the stopper fixed mode.

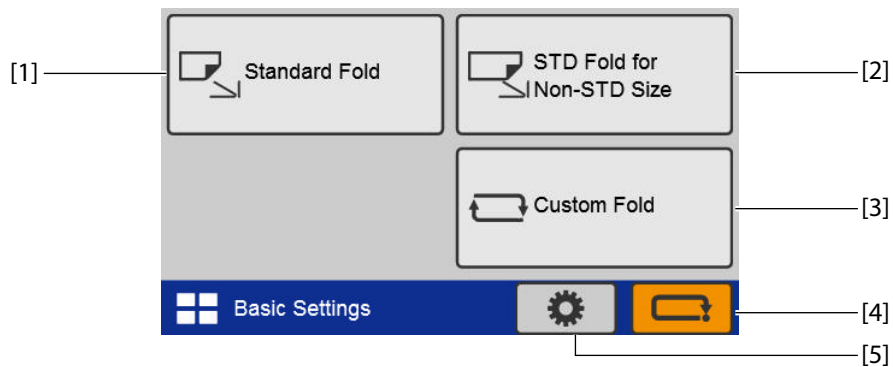
5-2. [Basic Settings] screen





No.	Name	Function
[1]	Standard Fold	Touch the key for standard folding. The [Folding Mode] screen is displayed. When automatic paper size detection is turned off, the [Standard Size] screen is displayed.
[2]	STD Fold for Non-STD Size	Touch the key for standard folding of non-standard paper. The [Paper Length] input screen is displayed.
[3]	Custom Fold	Touch the key for custom folding. The [Custom Fold] screen is displayed.
[4]	 (Cancel) key	Returns to the previous screen.
[5]	 (Function settings) key	The [Function Settings] screen is displayed.

5-3. [Standard Size] select screen

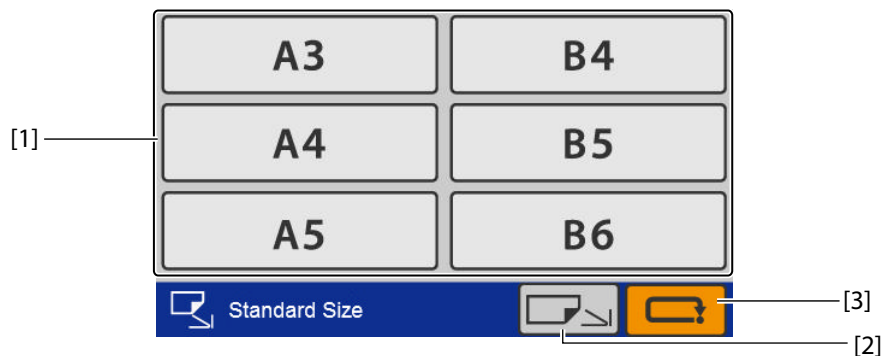



When automatic paper size detection is turned on, the following screen is not displayed.

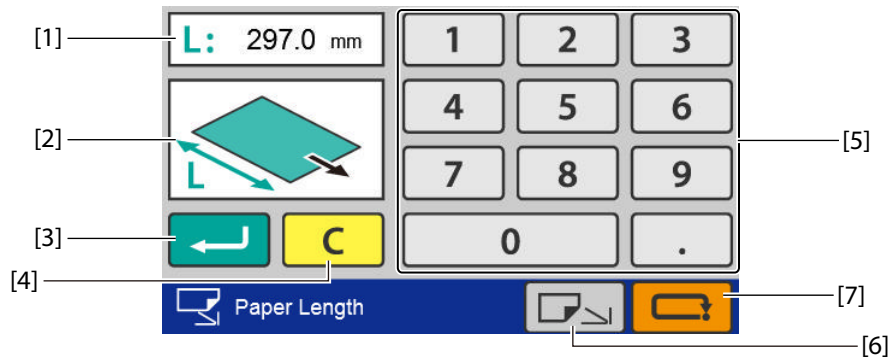

No.	Name	Function
[1]	Standard paper size key	Sets the standard paper size to be used. Depending on the set mode, there are restrictions on the paper that can be used. In that case, keys of standard paper sizes that cannot be used are grayed out and cannot be operated.
[2]	 (Non-standard size switching) key	The paper length input screen is displayed.
[3]	 (Cancel) key	Returns to the previous screen. Press and hold to return to the [Ready] screen.

5-4. [Paper Length] input screen (non-standard paper)







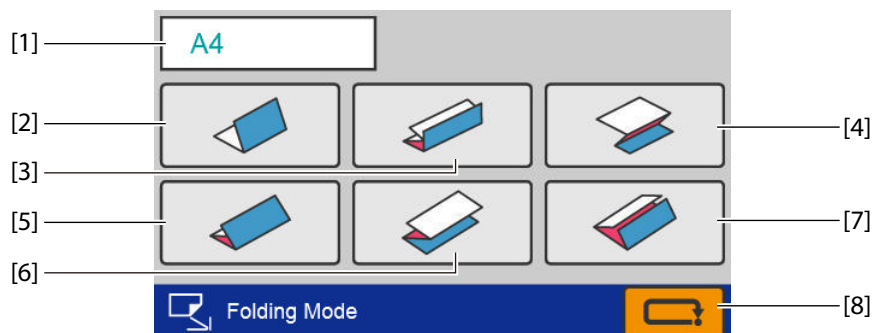

No.	Name	Function
[1]	Paper length setting value	Displays the currently set paper length.
[2]	Preview screen	Displays the position of the input value.
[3]	 (Return) key	Saves the input value and transits to the next screen. When you touch the key when the input value is outside the specification range, the value that you can specify is displayed on the preview screen.
[4]	 (Clear) key	Sets the input value to "0".
[5]	Numeric keypad	Inputs the value. Setting range: 182.0 to 457.2 mm/7.17 to 18.00 inches
[6]	 (Standard size switching) key	Either the [Standard Size] screen, [Ready] screen or [Custom Fold] screen is displayed. The displayed screen differs depending on the settings on the [Basic Settings] screen and on/off of the automatic detection of paper size. When the key is grayed out, it cannot be operated because a standard paper size is not detected.
[7]	 (Cancel) key	Returns to the previous screen without saving the input content. Press and hold to return to the [Ready] screen.

5-5. [Folding Mode] select screen







No.	Name	Function
[1]	Paper size display	Displays the currently set standard size. When non-standard size paper is set, the paper length is displayed.
[2]	 (Single fold) key	Sets the folding mode as single fold.

No.	Name	Function
[3]	 (Double fold) key	Sets the folding mode as double fold.
[4]	 (Irregular accordion fold) key	Sets the folding mode as irregular accordion fold-out.
[5]	 (Letter fold) key	Sets the folding mode as letter fold.
[6]	 (Accordion fold) key	Sets the folding mode as accordion fold.
[7]	 (Gate fold) key (*)	Sets the folding mode as gate fold.
[8]	 (Cancel) key	Returns to the previous screen without saving the input content. Press and hold to return to the [Ready] screen.

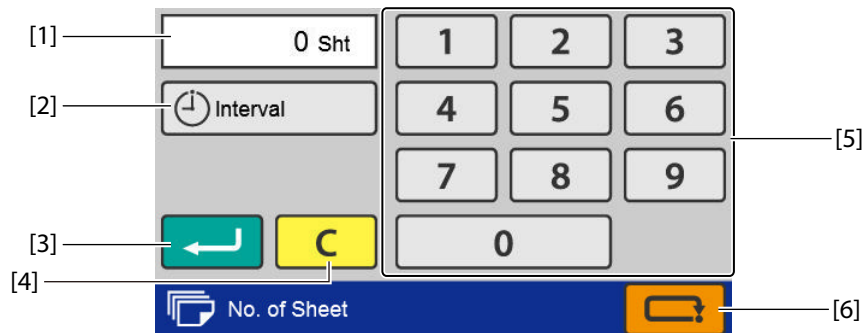
(*) Depending on the paper length that you set, the keys that cannot be used are grayed out and cannot be operated.

5-6. [No. of Sheet] input screen



No.	Name	Function
[1]	The number of sheets to be folded	Displays the currently set number of sheets to be folded.
[2]	[Interval] key	The [Interval] screen is displayed. (p.59)
[3]	 (Return) key	Saves the input value and returns to the [Ready] screen.
[4]	 (Clear) key	Sets the input value to "0".
[5]	Numeric keypad	Inputs the value. Input range: 0 to 99999 (sheets)
[6]	 (Cancel) key	Returns to the [Ready] screen without saving the input content.



5-7. [Fold Position] screen

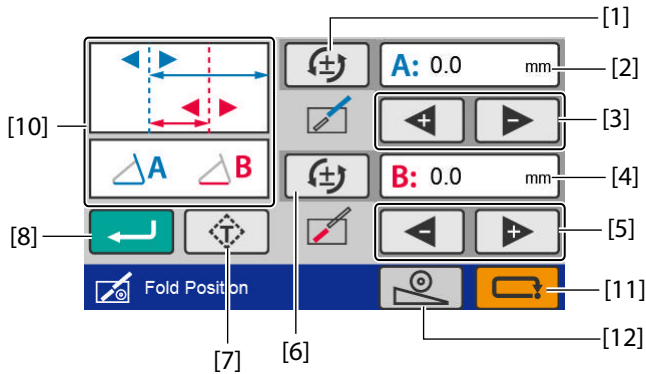

Standard fold/standard folding of non-standard paper

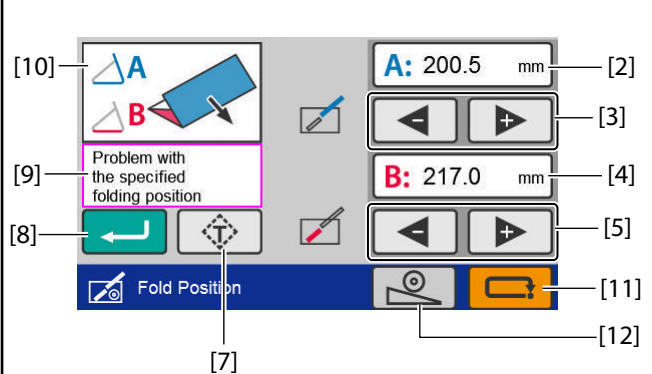

Custom folding







No.	Name	Function
[1]	Folding A reversal	Reverses [+] and [-] of folding dimension A. When the value after being reversed is outside the specification range, it is corrected to the nearest value within the specification range. When in custom folding or stopper fixed mode, it is not displayed.
[2]	Folding A position adjustment value/Folding dimension A position (*)	Standard folding: The folding A position adjustment value is displayed. Custom folding: The folding dimension A is displayed. When you touch the key, the numeric keypad is displayed, which enables you to input values.
[3]	Folding A position adjustment key (*)	Adjusts the position of the folding stopper of the folding plate 1. [+] Raises the position of folding A. When pressed and held, the value continues to increase automatically within the setting range. [-] Lowers the position of folding A. When pressed and held, the value continues to decrease automatically within the setting range.
[4]	Folding B position adjustment value/Folding dimension B position (*)	Standard folding: The folding B position adjustment value is displayed. Custom folding: The folding dimension B is displayed. When you touch the key, the numeric keypad is displayed, which enables you to input values.
[5]	Folding B position adjustment key (*)	Adjusts the position of the folding stopper of the folding plate 2. [+] Raises the position of folding B. When pressed and held, the value continues to increase automatically within the setting range. [-] Lowers the position of folding B. When pressed and held, the value continues to decrease automatically within the setting range.
[6]	Folding B reversal	Reverses [+] and [-] of the folding dimension B. When the value after being reversed is outside the specification range, it is corrected to the nearest value within the specification range. When in custom folding or stopper fixed mode, it is not displayed.
[7]	 (Test) key	Performs test fold before saving the adjusted value of the folding stopper position.
[8]	 (Return) key	Saves the input value and returns to the [Ready] screen. When you touch the key while the input value is outside the specification range, the value within the range that you can input is displayed in "outline of folding dimension."

No.	Name	Function
[9]	Warning message	When the input value is outside the specification range, a warning message is displayed.
[10]	Outline of folding dimension	The outline of folding position for the selected folding form is displayed.
[11]	 (Cancel) key	Returns to the [Ready] screen without saving the input content.
[12]	 (Stacker roller) key	The [Stacker Roller] screen is displayed. When the combination of position adjustment values is invalid, a warning message is displayed and the [Stacker Roller] screen is not displayed.

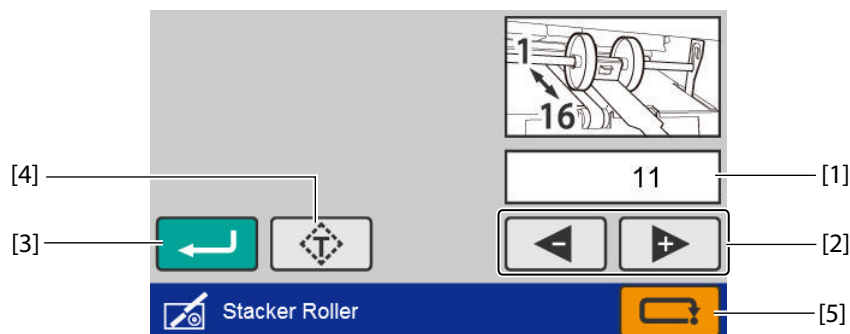
(*) This is not displayed depending on the folding mode selected.

5-8. [Stacker Roller] screen









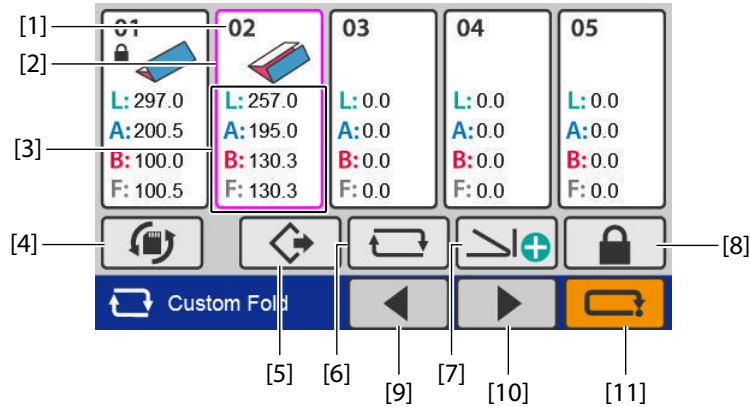

No.	Name	Function
[1]	Stacker roller position	Displays the position of the stacker roller.
[2]	Stacker roller adjustment key	[+] Raises the position of the stacker roller. When pressed and held, the value continues to increase automatically. [-] Lowers the position of the stacker roller. When pressed and held, the value continues to decrease automatically.
[3]	 (Return) key	Saves the input value and returns to the previous screen.
[4]	 (Test) key	Performs test fold before saving the adjusted value of the stacker roller position.
[5]	 (Cancel) key	Returns to the previous screen without saving the input value.

5-9. [Custom Fold] screen





Saved data selection screen

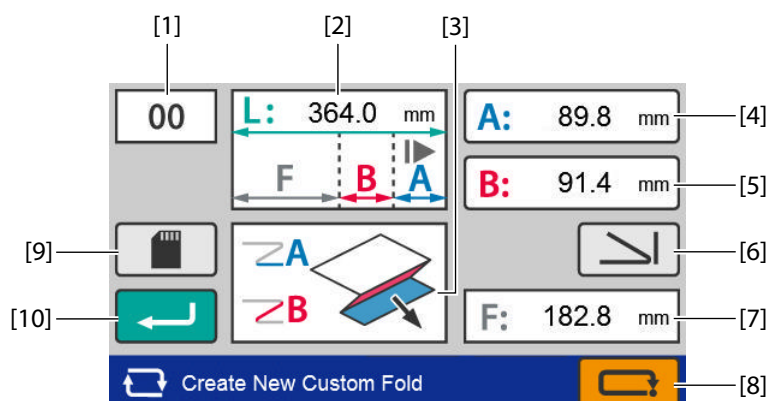

No.	Name	Function
[1]	Saved data number/Saved data lock display	☞ "5-1-1. Touch panel display" (p.11)
[2]	Selection frame	Touch to select the saved data you want to use. The color of the frame of the selected saved data changes.
[3]	Custom fold data	Displays the length of each fold saved. L: Paper length A: Folding A length B: Folding B length F: Finishing length
[4]	 (Switch to save screen) key	Displays the [Save] screen.
[5]	 (Open) key	Reads the selected saved data and returns to the [Ready] screen. When non-saved data is selected, the key is grayed out and cannot be operated.
[6]	 (Edit) key	Displays the [Paper Length] input screen for the selected saved data.
[7]	 (Create new) key	Creates new data.
[8]	 /  (Lock/Unlock) key	Locks or unlocks the selected saved data. Locked data cannot be deleted. When non-saved data is selected, the key is grayed out and cannot be operated.
[9]	 (Page backward) key	Moves to the previous page.
[10]	 (Page forward) key	Moves to the next page.
[11]	 (Cancel) key	Returns to the [Basic Settings] screen. Press and hold to return to the [Ready] screen.

Editing screen







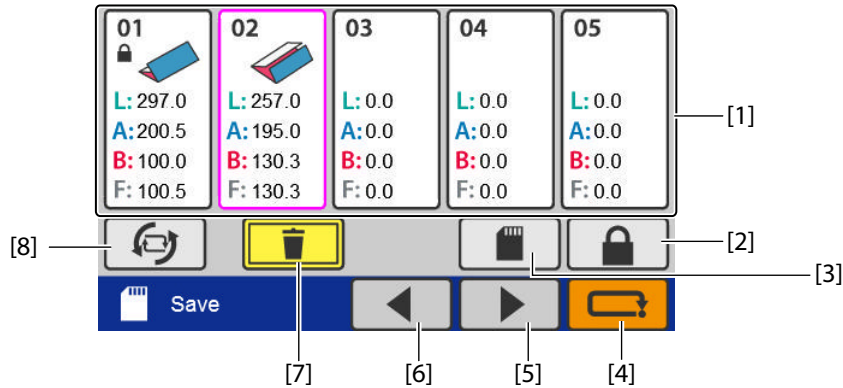

No.	Name	Function
[1]	Saved data number display	Displays the number of the data being edited. When data is newly created, [00] is displayed.
[2]	Paper length	Displays the currently set paper length.
[3]	Folding form outline display	Displays a rough shape of the folding form.
[4]	Folding A setting	Displays currently set folding A length. When the key is touched, the [Edit] screen of folding A is displayed. Setting range: 42.0 to *** mm/ 1.65 to *** inch ***: 325.0 mm/12.80 inches or "Paper length + 5.0 mm/+0.197 inch", whichever is shorter.
[5]	Folding B setting	Displays the currently set folding B length. When the key is touched, the [Edit] screen of folding B is displayed. When folding B is not used, set as 0.0 mm. Setting range: 0.0/47.0 to *** mm/ 1.85 to *** inches ***: 217.0 mm/8.54 inches or "paper length + 5.0 mm/+0.197 inch", whichever is shorter.
[6]	 (Folding mode selection) key	When the key is touched, the [Folding Mode] screen is displayed. When folding mode is set, value of the folding A and folding B is input automatically according to the paper size and folding form, and display returns to this screen.
[7]	Finishing size	Displays the estimated value of the finishing length based on the input value and folding form.
[8]	 (Cancel) key	When you enter this screen from the [Basic Settings] screen, the display returns to the [Paper Length] input screen. In this case, the values of folding A and folding B that you have input are temporarily saved, and the values are restored when you save the paper length. When you touch the  key on the [Paper Length] input screen, however, the temporarily stored values are discarded. Press and hold to return to the [Ready] screen.
[9]	 (Save) key	Saves the input value and displays the [Save] screen. When the combination of input values is in the following conditions, the data becomes invalid and cannot be saved. <ul style="list-style-type: none"> - The value of folding A is set to [0]. - Folding A is larger than L (the paper length). - Folding B is larger than both folding A and "L - folding A".

No.	Name	Function
[10]	 (Return) key	Saves the input value and returns to the [Ready] screen. The input value is not saved.



[Save] screen

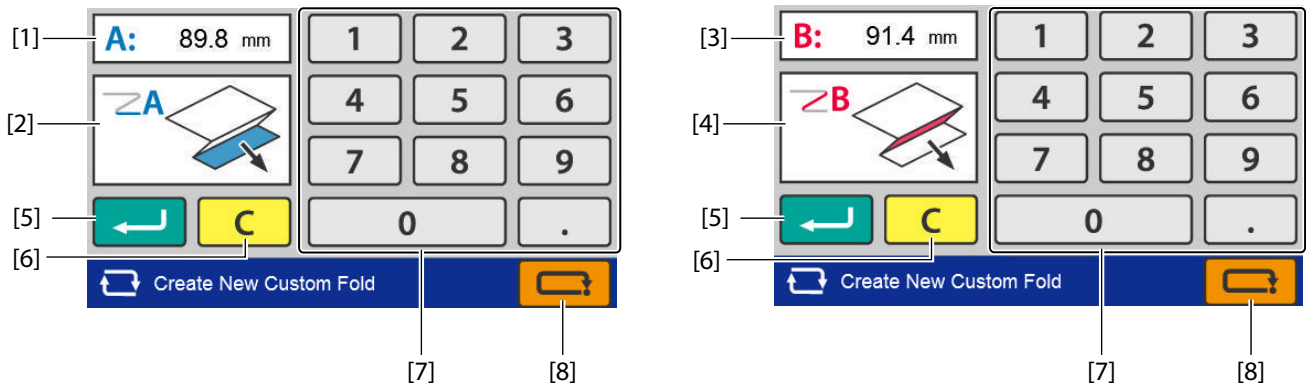

No.	Name	Function
[1]	Custom fold saved data	☞ "5-9. [Custom Fold] screen" (p.20)
[2]	 (Lock/unlock) key	
[3]	 (Save) key	Saves the setting content. When creating new data, custom fold data is saved in the free space. When there is no free space, the key is grayed out and cannot be operated. When saved data is edited, data is overwritten and saved. When you enter this screen from the [Ready]/[Basic Settings] screen, the display returns to the [Ready] screen.
[4]	 (Cancel) key	Returns to the custom fold edit screen. Press and hold to return to the [Ready] screen.
[5]	 (Page forward) key	Moves to the next page.
[6]	 (Page backward) key	Moves to the previous page.
[7]	 (Delete) key	Press and hold to delete the selected saved data. While non-saved data or locked data is selected, the key is grayed out and cannot be operated.
[8]	 (Switch to the saved data selection screen) key	Displays the saved data selection screen.

5-10. Folding A/Folding B input screen





No.	Name	Function
[1]	Folding A setting value display	Displays the currently set folding A value.
[2]	Folding A outline display	Displays the position of folding A on the paper. When the input value is outside the specification range, a warning message is displayed.
[3]	Folding B setting value display	Displays the currently set folding B value.
[4]	Folding B outline display	Displays the position of folding B on the paper. When the input value is outside the specification range, a warning message is displayed.
[5]	 (Return) key	Saves the input value and returns to the [Custom Fold] screen.
[6]	 (Clear) key	Sets the input value to "0".
[7]	Numeric keypad	Inputs the value. Setting range Folding A: 42.0 to *** mm/1.65 to *** inches ***: 325.0 mm/12.80 inches or "Paper length + 5.0 mm/+0.197 inch", whichever is shorter. Folding B: 0/47.0 to *** mm/1.85 to *** inches ***: 217.0 mm/8.54 inches or "Paper length + 5.0 mm/+0.197 inch", whichever is shorter.
[8]	 (Cancel) key	Returns to the previous screen without saving the input content. Press and hold to return to the [Ready] screen.

5-11. Function Setting screen

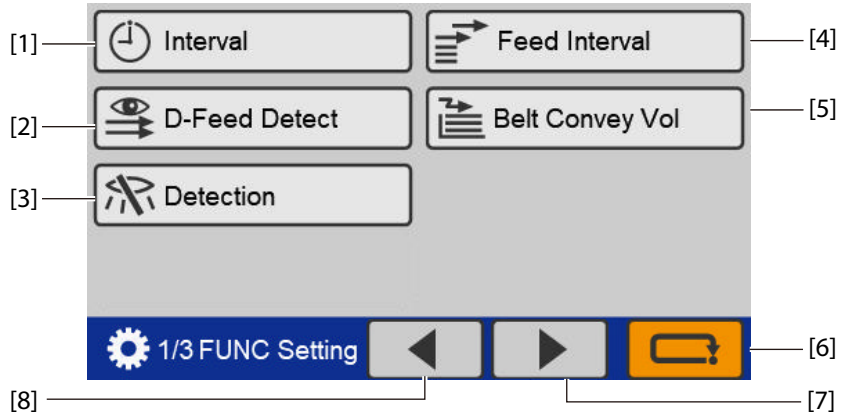
[1/3 FUNC Setting] screen

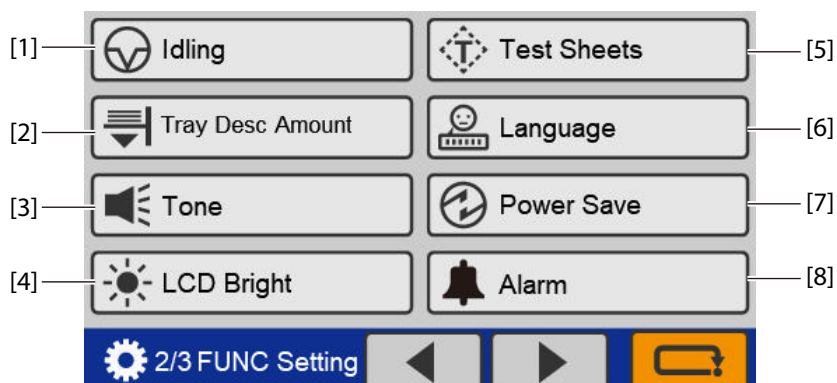

No.	Name	Function
[1]	Interval	Sets whether to use the interval (division) function or not. (p.59)
[2]	D-Feed Detect (Double Feed Detect)	Sets whether to perform double-feed detection or not. (p.61)
[3]	Detection	Sets whether to perform paper stacked/standard size detection or not. (p.62)
[4]	Feed Interval	Sets a feed interval. (p.63)
[5]	Belt Convey Vol	Sets the amount of conveyance. (p.63)
[6]	 (Cancel) key	When touched, the display returns to the [Basic Settings] screen. Press and hold to return to the [Ready] screen.
[7]	 (Page forward) key	Moves to the next page.
[8]	 (Page backward) key	Moves to the previous page.

[2/3 FUNC Setting] screen

No.	Name	Function
[1]	Idling	Sets whether or not to perform idling operation. (p.64)
[2]	Tray Desc Amount	Sets the tray descended amount. (p.65)
[3]	Tone	Sets whether to enable or disable the buzzer (key operation sound on the control panel). However, the buzzer that sounds when an abnormality occurs will sound even if the setting is disabled. (p.66)
[4]	LCD Bright	Sets the brightness of the LCD touch panel screen. (p.66)
[5]	Test Sheets (The Number of Test Sheets)	Sets the number of test feed sheets. (p.67)
[6]	Language	Switches the language displayed on the touch panel. (p.67)
[7]	Power Save	Sets whether or not to turn off the LCD touch panel screen automatically. (p.68)
[8]	Alarm	Sets whether or not to use an alarm to prevent forgetting to switch off the power. (p.69)

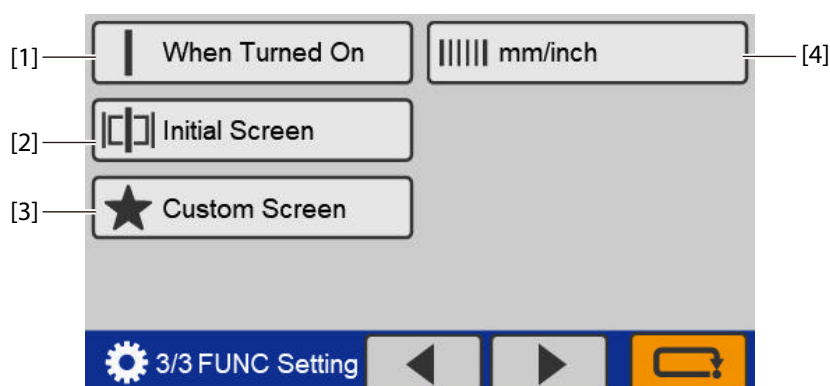
[3/3 FUNC Setting] screen

No.	Name	Function
[1]	When Turned On	Sets the operation mode when the power is turned on. (p.70)
[2]	Initial Screen	Sets the initial screen when the power is turned on. (p.71)
[3]	Custom Screen	Sets a custom screen (p.72)
[4]	mm/inch	Switches the unit used for paper length. (p.73)

5-12. Classification of buzzer sounds

In this machine the buzzer sounds in confirmation when setting on the control panel or paper runs out on the paper feed tray. Classification of the sounds is as follows.

“pi”: Operational sound at the time of normal key operation

“pipi”: Warning alarm at the time of mis-operation, mis-feed of paper, or paper empty

“pii”: At the start of folding operation or end of normal folding operation.

When saving changes in various settings. The time when you set the alarm has come.

“piipii”: At the occurrence of an error such as paper jam

“piipiipiipi”: At the occurrence of an error to be asked for Formax dealer’s assistance

6. Paper Types and Sizes

Paper type

Fine quality paper : 52.3 to 157 g/m²/35.56 to 106.76 lb

Particular paper

Art paper, coated paper: 73.3 to 157 g/m²/49.84 to 106.76 lb

Paper size

Standard Paper

The standard paper can be used only when it is stacked in portrait orientation.

A3/B4/A4/B5/A5/B6 (For EU), LGR/LGL/LTR/STMT/INV (For North America)

Non-standard paper

[a] : 120.0 to 311.0 mm/4.73 to 12.24 inches

[b] : 182.0 to 457.2 mm/7.17 to 18.00 inches

The aspect ratio for non-standard paper is 1:1 to 2.2:1.

Some limitations in setting and paper quality may be applied depending on paper size.

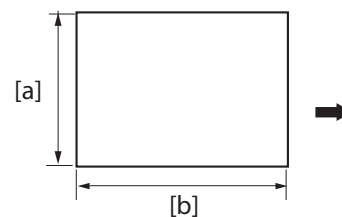

Paper that cannot be used with this machine

- Paper out of specifications
- Curled paper
- Wavy paper

7. Handling Paper

7-1. Paper used

- Make sure that the printing ink on the paper has dried completely prior to use.

- ▼ • **Wet ink or ink that is not completely dried may stain the folding roller causing trouble such as smearing on paper.**
- **Use of paper printed with special types of ink may cause the folding roller to swell or deform, and folding misalignment may occur.**

- Paper may not be fed smoothly into the folding plate or deformed folding may occur depending on different environmental factors (temperature, humidity), paper ream weight, paper type, paper grain direction if curled paper is used. Make sure to flatten curled paper or paper with folded lines before use.
- Separate the sheets of paper well before stacking them.

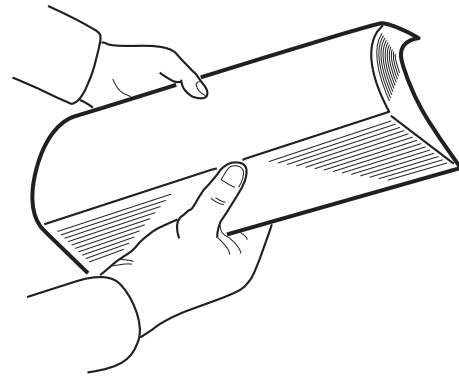

7-2. Precautions on stacking paper

- [a] Do not stack the sheets of paper on the paper feed tray with the sides of sheets unaligned or some sheets protruding from the stack.

This machine has an automatic standard paper size detection function. It automatically detects paper size at the paper feed guides. Therefore, if paper is protruding out from the left or right side, it is unable to detect paper size accurately and may determine standard paper as non-standard.

- [b] Do not stack paper on the paper feed tray with the lead and trail edges unaligned or some sheets protruding out.

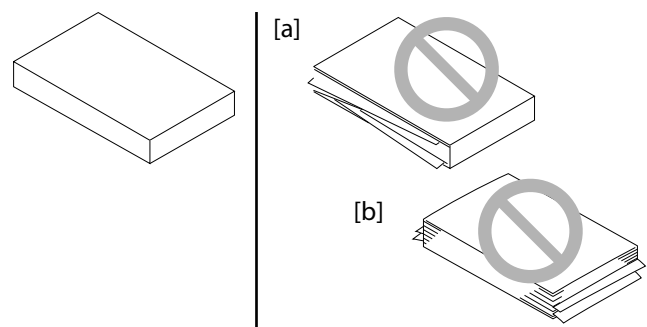

- ▼ • **Processing with sheets unaligned on the right or left side may cause such trouble as folding misalignment and jamming.**
- **Processing with sheets unaligned on the lead and trail edges may lead to unstable feed causing such trouble as miss-feed and double-feed.**

8. Workflow

The following flowchart illustrates the flow of basic operation. For details, refer to the text and relevant pages.

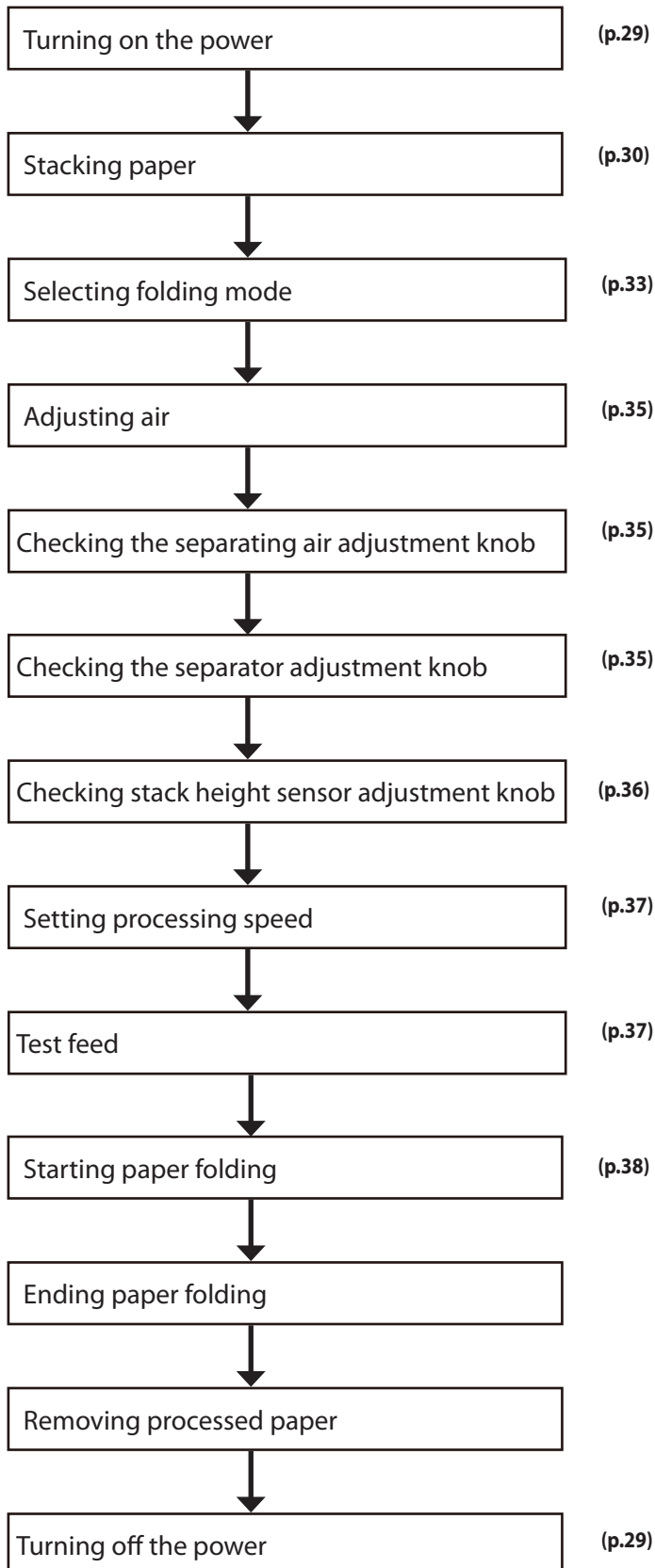

Chapter 2 Basic Operation

1. Turning On/Off Power

▼ Use the supplied power cord.



1-1. Installing power cord

1 Install the power cord to the machine.

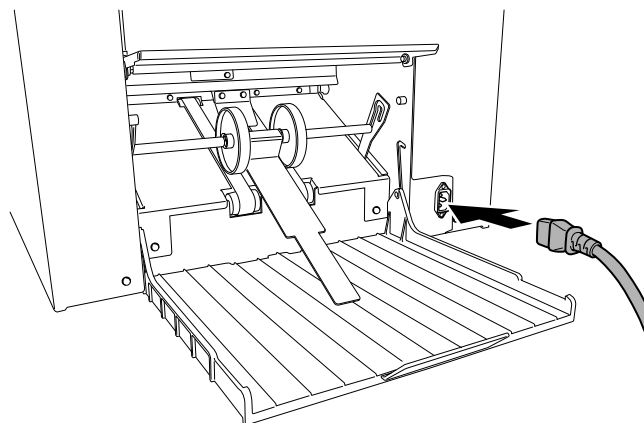

2 Connect the power plug to the outlet with earthing connection.

1-2. Turning on power

Set the power switch to the " I " side.

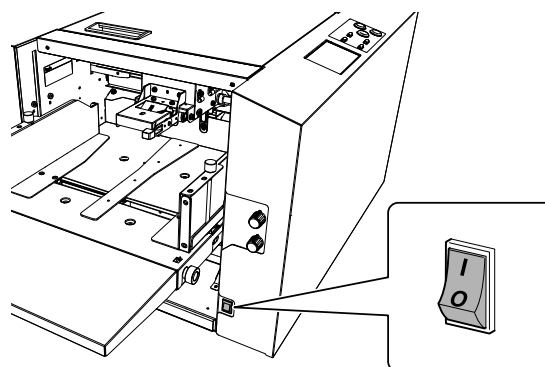

1-3. Turning off power

Set the power switch to the " O " side.

2. Stacking the Paper

2-1. Before stacking paper

Checking the front/back,top/end of paper

Check the "front/back" and "top/end" of paper when stacking paper on the paper feed tray.

Check for folding misalignment, and check "front/back" and "top/end" of paper when checking the finished fold after test folding.

When paper is stacked with the gray surface on the obverse side and white surface on the reverse side on the paper feed tray, and processing is completed in the standard folding mode, the folded paper is as shown in the figure.

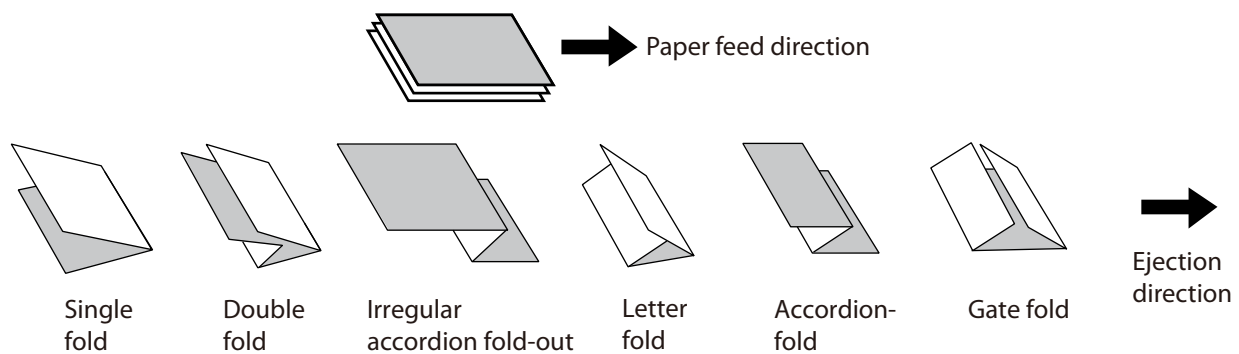

2-2. Stacking paper

⚠ CAUTION

- Do not put fingers inside during operation.**
- Keep away long hair, ties, jewelry and loose clothing.**
- It could cause injury.**

1 Loosen the guide fixing screw.

2 Stack paper on the paper feed tray.



The round hole (upper side) on the paper feed guide indicates the maximum paper stacking height 50 mm/1.97 inches [a].

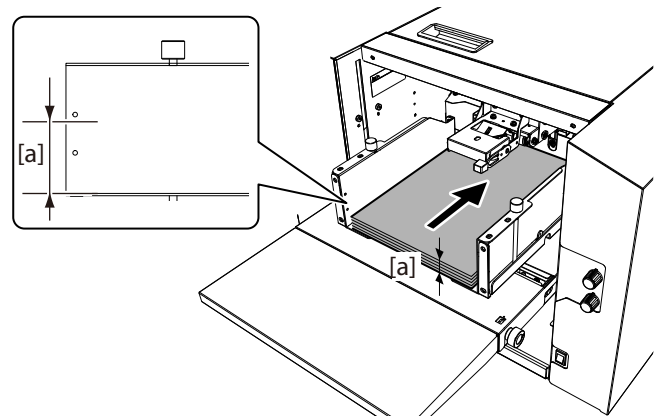

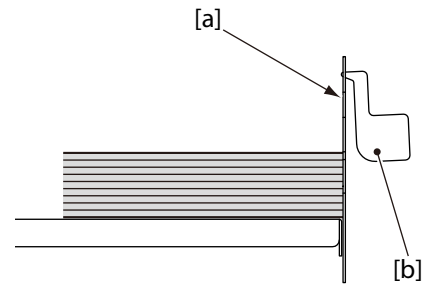

Stack paper striking the leading edge of paper lightly at the shutter. [a]

- ! **If there is some clearance between the leading edge of paper and shutter, the paper detecting sensor [b] does not function properly.**



3 Adjust the paper feed guide to match the paper size.

Set the paper feed guide in such a way that it touches the paper lightly.

- ! **Do not press the paper with the paper feed guides too strongly. Otherwise, paper feed errors such as mis-feed will occur.**
- ! **If the guides are positioned incorrectly, the automatic paper size detection function will not work, and the  key or  key, etc. will not operate. (p.33)**

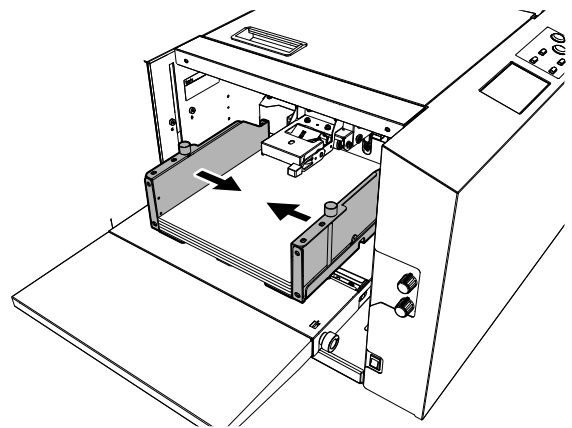

4 Tighten the guide fixing screws.

- ! **Make sure to tighten the guide fixing screws on both right and left sides. If the screws are not fixed, the paper feed guide moves during operation, and folding misalignment may occur in the right and left direction.**

5 Set the trail edge guide unit to the rear end of paper.

Set the trail edge guide unit so that it will be in contact with the paper lightly.

- ! **Make sure to place the trail edge guide unit. When starting the machine without it, the paper will be blown by separating air.**

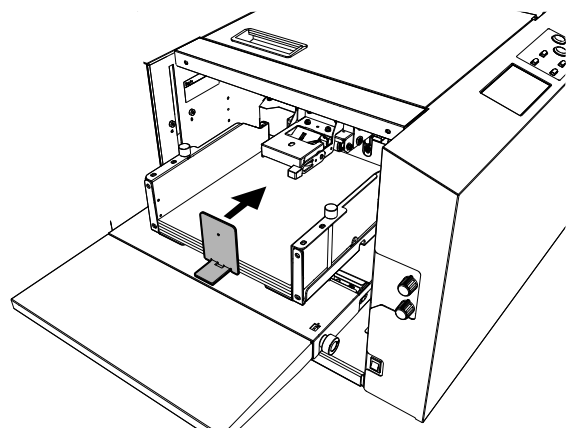

When processing long paper, use the plate unit and side guide unit.

Range of paper length: A3 (LGR) or more, or trail edge of paper is positioned at more than two-third of auxiliary paper feed tray.

6 Set the plate unit onto the auxiliary paper feed tray.

Be sure to set the plate unit so that it does not extend beyond the rear end of paper.

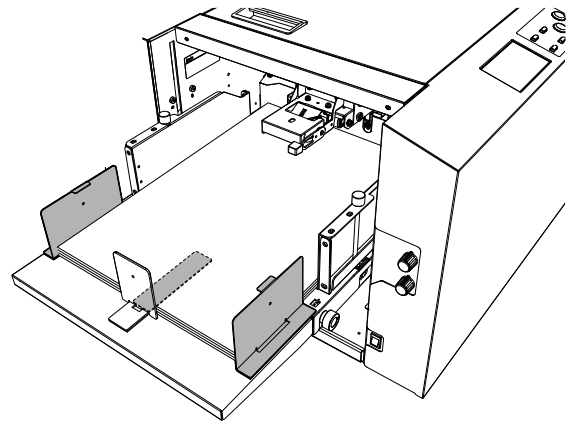



7 Attach the side guide unit on each side of paper.

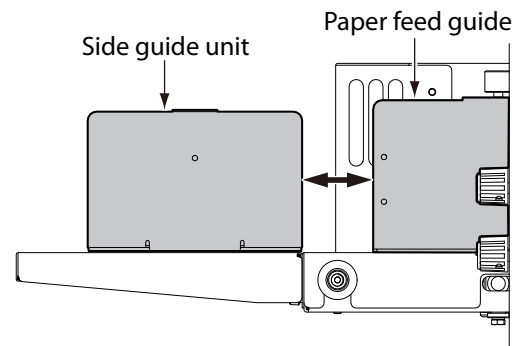

- Attach the side guide unit leaving some clearance between the side guide unit and paper. However, if the side guide unit is set leaving too much clearance between the side guide and paper, accuracy of feeding may be lowered, and folding misalignment may be apt to occur. If the side guide unit is set striking at the paper, double-feed or mis-feed may be caused.
- Make sure to leave space between the paper feed guide and the side guide unit as shown in the right figure.



Automatic rise/descent of the paper feed tray

- When paper is stacked on the paper feed tray, the paper feed guides are set, and the  key or  key is pressed, the paper feed tray rises automatically. (p.62)



When using large or heavy paper, the paper feed tray may become over stacked and may not be able to rise due to paper weight. In such cases, stack less paper.

- The paper feed tray descends automatically when paper is removed from the paper feed tray. It will also descends automatically when paper runs out on the paper feed tray during a folding operation.
- When [Detection] is turned off, the paper stacked on the tray is not detected. Therefore, when the operation stops, the paper feed tray goes down automatically even if paper is stacked on the tray.

3. Standard Folding of Standard Paper



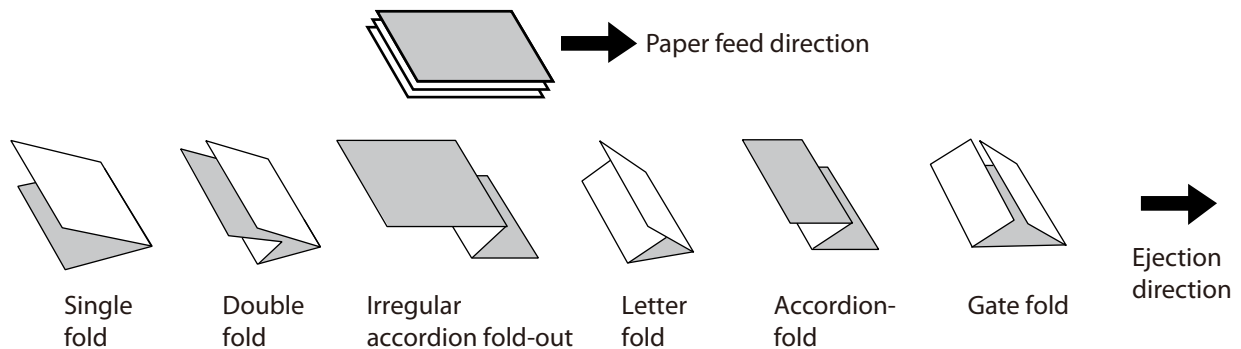

Method to fold standard paper by setting a mode among standard folding modes displayed on the control panel.

 For the standard paper sizes, refer to Chapter 1 "6.Paper Types and Sizes" (p.26).

Six standard folding modes are available as shown below.



Depending on the thickness of paper, this machine may not be able to process some standard sheets of paper.

 CAUTION	
	Do not put fingers inside during operation.
	Keep away long hair, ties, jewelry and loose clothing.
	It could cause injury.

Automatic detection of standard paper size

When paper for all paper sizes is stacked in the machine direction shown in the figure, paper is detected as standard paper.

- !** When paper of standard paper size is stacked on the paper feed tray in the sideways, the paper size is detected as wrong paper size. Use paper as non-standard paper when stacking paper in the sideways.

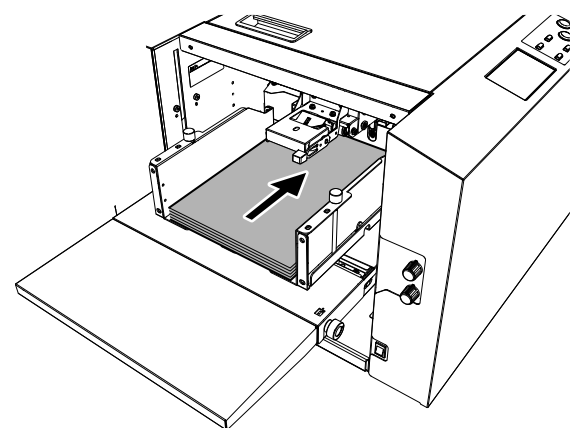

 For the use of non-standard paper, refer to Chapter 3 "2.Standard Folding of Non-Standard Paper" (p.46)

The operating procedure will be explained using the example of when the paper size is "A4" and the folding mode is "single Fold."

1 Touch the  key on the [Ready] screen.

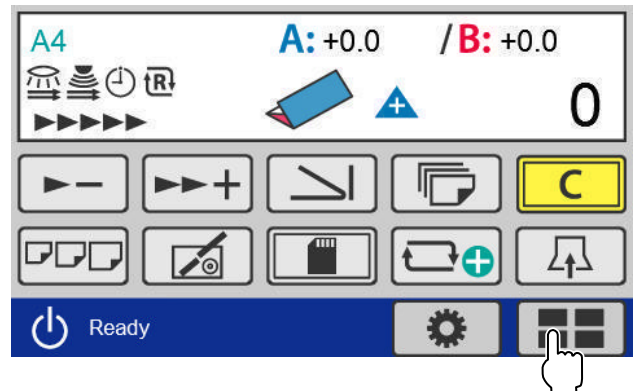

2 Touch the [Standard Fold] key.
The standard size setting screen is displayed.

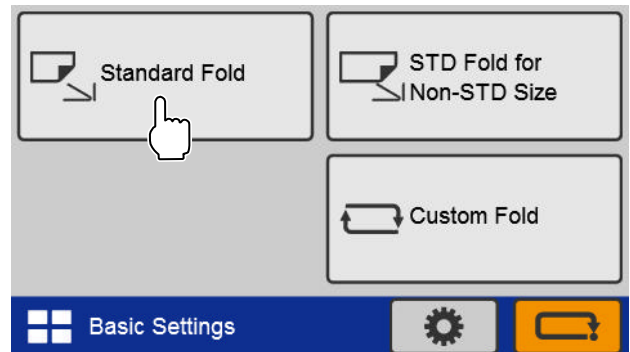

3 Touch the [A4] key.
When automatic detection of a paper size is set to on, this screen is not displayed. Go to step 4.

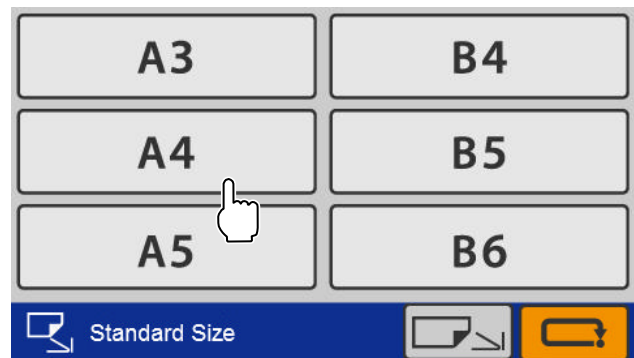

4 Touch the  key.
Return to the [Ready] screen.

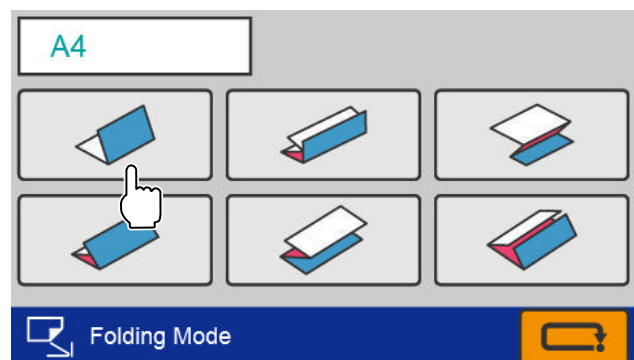

5 Touch [Air Adjust].

The [Air Adjust] screen is displayed.

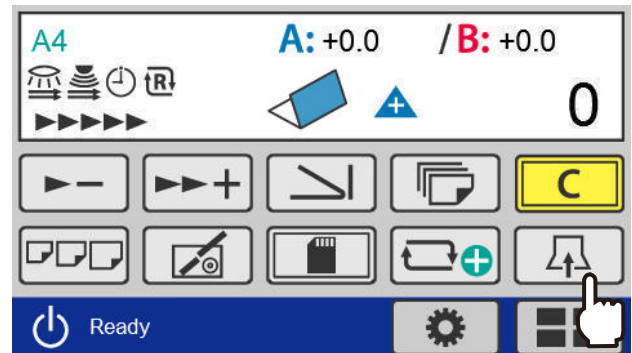

6 Set [Separating Air],[Pickup Air] and [Side Air].



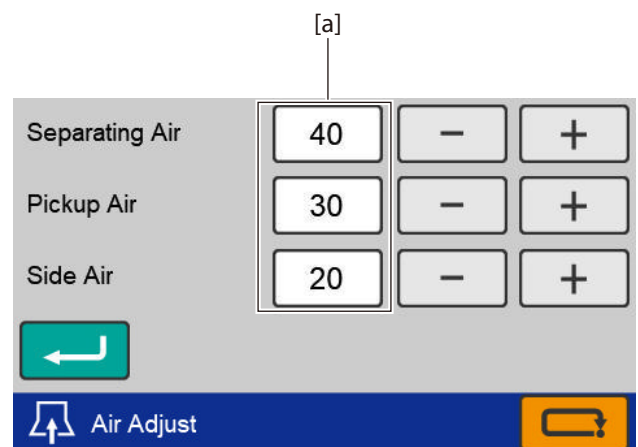

- Adjust a value using [-] or [+].
- To enter a value, touch [a]. The numeric keypad is displayed.
- The appropriate value for the separating air and pick up air vary depending on the paper type and ream weight. (p.39)



7 Touch the key.

The value is confirmed.



- The volume of [Air Adjust] can be checked by pressing the  key or  key while [Air Adjust] window is displayed.
- Press either of the  key or  key to stop separating air.
- When the air volume is appropriate, the paper does not flap but it floats as air reaches the rear end of paper as shown in the right figure.

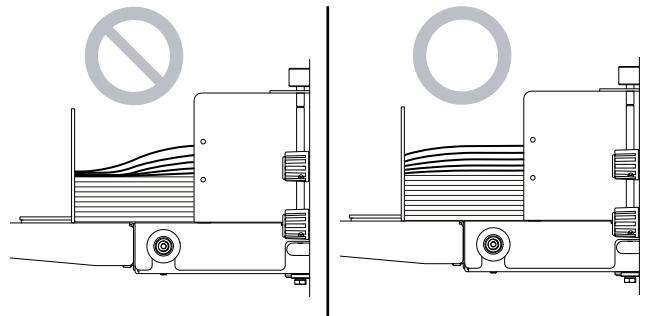

8 Check that the separating air adjustment knob is set to [2].

- Larger settings increase and smaller settings decrease the amount of air.
- Set the air volume to [4] to [5] as paper is heavy when handling large size paper.
- Set the knob to [1] when using small size thin paper.

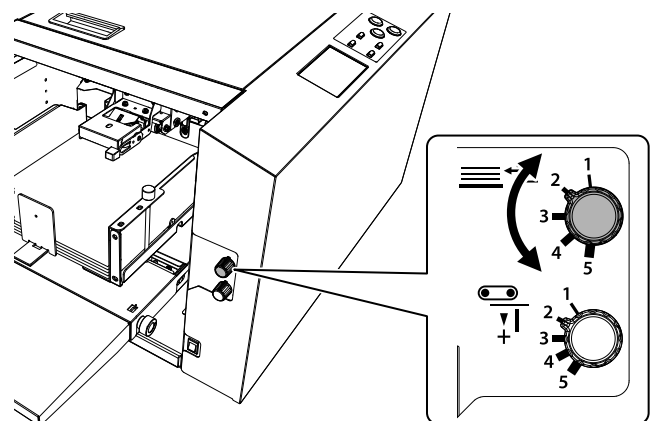

9 Check that the separator adjustment knob is set to [2]. (The separator should be lightly in contact with the suction belt.)

- The larger the setting, the wider the space between the separator and the suction belt.
- Turn the knob towards [3] if mis-feed occurs.
- Turn the knob towards [1] if double-feed occurs.

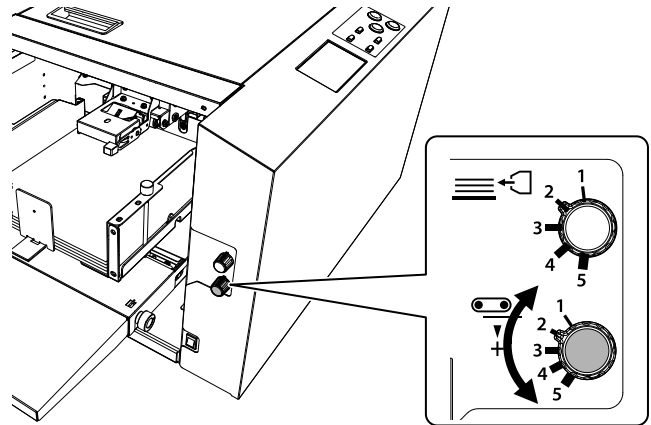

10 Check that the stack height sensor adjustment knob is set to the standard position (the second scale from the bottom).

- Setting the knob to the upper scales (round hole) lowers feeding position, and setting the knob to the lower scales raises feeding position.
- Lower the sensor knob by one scale if mis-feed occurs.
- Raise the sensor knob by one scale if double-feed occurs.

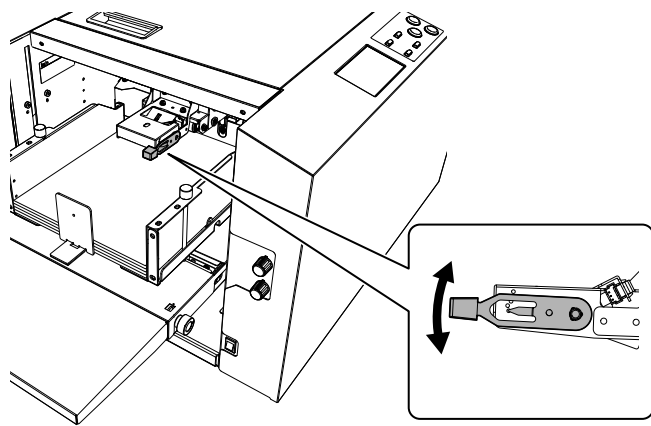

! A feed error may occur when stopping feeding paper with the scale of stack height sensor adjustment knob set to the first scale, and restarting feeding paper with smaller amount of paper on the paper feed tray. If so, match the stack height sensor adjustment knob with paper and set it to the following position.

- Thin paper [a]: between the second scale and third scale from the bottom
- Thick paper [b]: between the first scale and second scale from the bottom

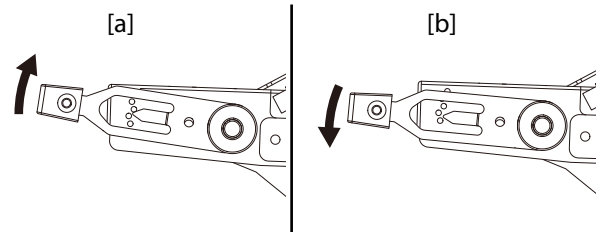

11 Touch the or key to set the processing speed.

- If folding misalignment occurs, decrease the processing speed.
- When paper jam or abnormal folding occurs by using thin and flimsy paper, adjust the processing speed referring to "Thin paper mode". (p.59)
- The processing speed can be changed during folding process or in the idling state. However, folding misalignment may be caused by changing the processing speed largely.

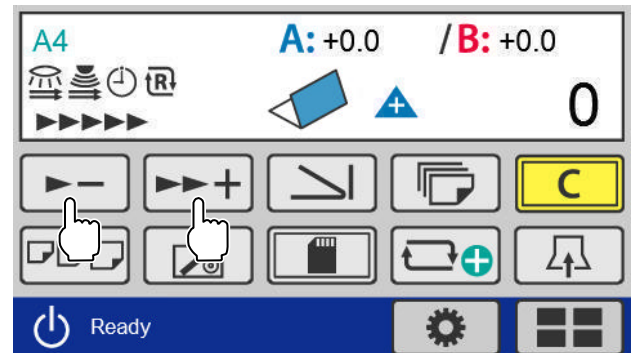

! When setting the folding mode of B6 size paper to double fold, the operable processing speed is [4] or more. Even if the processing speed is set to [0] to [3], the processing speed will be changed automatically to [4] when the  key or  key is pressed.

12 Adjust the position of the paper receiving tray.

Set to [A] to stack ejected paper diagonally.
Set to [B] to stack ejected paper straight. (p.57)

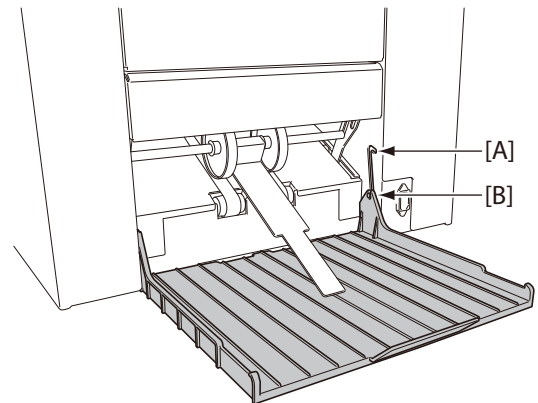

13 Press the key.

Perform test folding.
Test folded paper are not counted in the number of sheets processed.

! If this machine does not start by pressing the  key, automatic detection of paper size may not function. Check the paper feed guide is set appropriately to the scale of paper size.

14 Check the finish of test folding.

Check the last sheet of test folded paper for folding misalignment. (p.42)

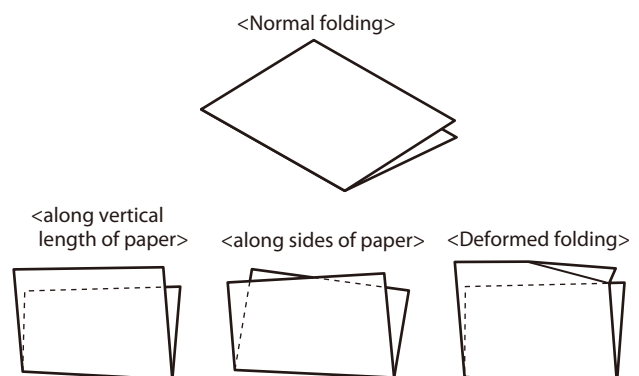

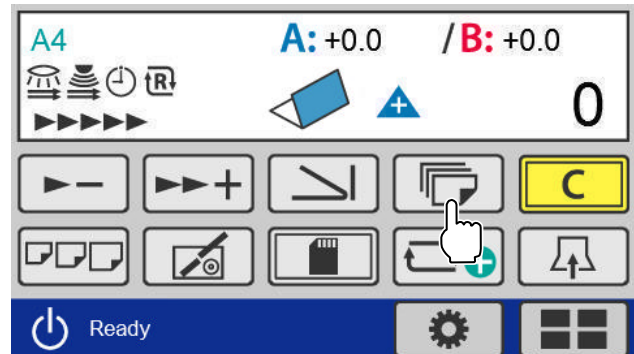

15 Touch the  key.

The number of sheets input screen is displayed.



Count up

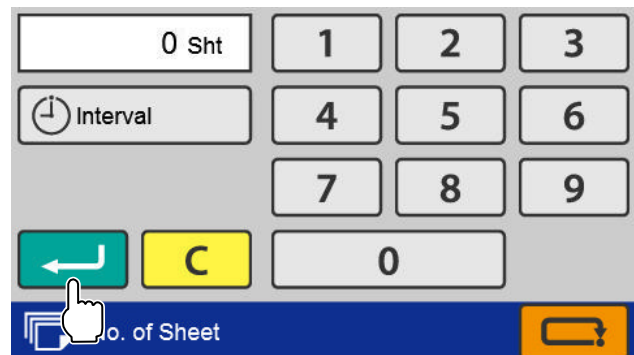

Touch the  key.

- If you press the  key without setting the counter to [0], the paper folding operation restarts and the number of sheets set for processing is incremented from the current value.
- When the count display reaches [99999], the machine stops operating. To continue paper folding processing, return the counter display to [0] and then press  key.





Count down

Using the numeric keypad, enter the number of sheets to be folded —> Touch the  key.

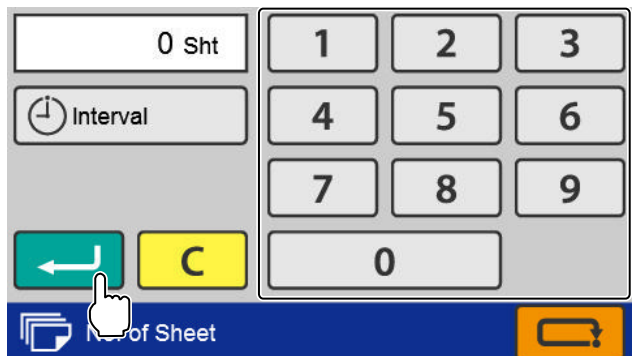
- The maximum display digit number is 5 digits (99999).
- When processing of the set number of sheets to be folded is completed, the machine stops operation and the count display returns to the set number of sheets.
- When you touch the  key and set the counter to [0], the usage method is changed back from "subtraction" to "addition".
- If you touch the  key without touching the  key, the folding operation restarts and the number of sheets set for processing is counted down from the current value.



16 Press the  key to start folding.

- Press the  key to interrupt or stop operation. Press the  key again to restart operation.
- If the paper in the paper feed tray runs out, the machine is put on standby. After stacking paper, press the  key to restart the operation.
- When double-feed or paper size error occurs during folding operation, the fed paper is processed and ejected, but the number of processed sheets will not be counted.
- When paper jams at the ejecting section, the paper detected as paper jam will be counted, but the following paper will not be counted.

Air Adjustment Table

The air adjustment table is a guide to set numerical values. The setting range of each setting is the following numerical value ± 5 . Depending on paper, the numerical values in () in the table will be the appropriate setting range.

Set each air volume to a smaller value than that of the table, when handling thin and flimsy paper such as rough paper and recycled paper. The larger the air volume, the more folding misalignment may occur.

Change the numerical value when double-feed or mis-feed occurs even though the values are set according to the air adjustment table.

Paper quality	Paper ream weight (g/m ² / lb)	A3 / LGR		A4 / LGL,LTR		A5 / INV, STMT	
		[Separating Air]	[Pickup Air]	[Separating Air]	[Pickup Air]	[Separating Air]	[Pickup Air]
Fine quality paper	52.3/14	35	30 (25 to 40)	35	30	40	30
	64/16	40	35	40	35	45	30
	81.4/22	50	45	45	40	50	35
	104.7/28	60	45	50	45	50	40
	127.9/34	65	50	55	45	50	40
	157/40	75	50	60	50	50	45
Coated paper	73.3/19	45 (40 to 55)	40 (35 to 50)	40	35	45	30
	79.1/21	50	40 (35 to 50)	45	40	45	35
	84.9/22	55	45	45	40	45	35
	104.7/28	65	50	55	45	50	40
	127.9/34	75	50	60	50	50	40
	157/40	85	55	75	50	70	45

Paper quality	Paper ream weight (g/m ² / lb)	B4		B5		B6	
		[Separating Air]	[Pickup Air]	[Separating Air]	[Pickup Air]	[Separating Air]	[Pickup Air]
Fine quality paper	52.3/14	40	35	40	30	40	30
	64/16	40	35	45	35	45	30
	81.4/22	45	40	50	40	50	35
	104.7/28	55	45	55	45	50	40
	127.9/34	60	45	60	50	60	40
	157/40	65	50	60	50	65	40
Coated paper	73.3/19	45	35	40	30	45	35
	79.1/21	45	40	45	35	45	35
	84.9/22	50	40	50	40	50	40
	104.7/28	60	45	55	45	50	40
	127.9/34	70	50	60	45	50	40
	157/40	80	50	60	50	70	40

4. Storage of Machine

Store the machine as follows, when it is not used.

1 Turn off the power switch.



2 Disconnect the power plug from the outlet.



3 Remove the power cord from this machine.

4 Remove the auxiliary paper ejection guide.

5 Hang the hook section of the paper receiving tray.

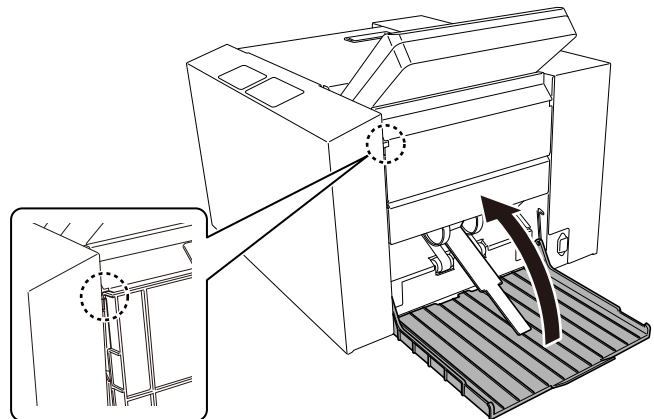

6 Hang the auxiliary paper ejection guide on the paper receiving tray.

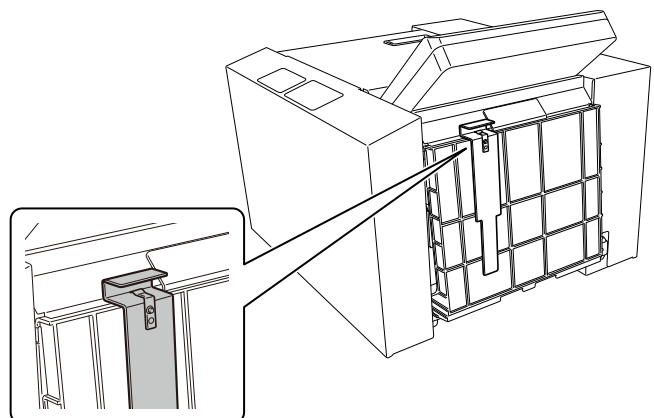

7 Loosen the setting screws.

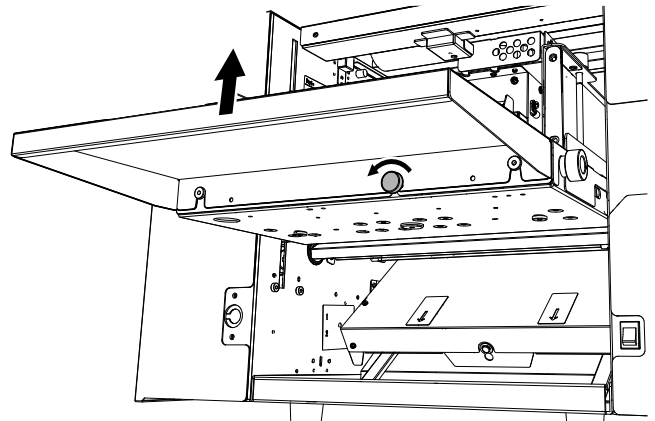



8 Remove the auxiliary paper feed tray.

Chapter 3 Advanced Operation

1. Correcting Folding Misalignment

Folding misalignment consists of “folding misalignment along the sides of the paper” and “folding misalignment along the vertical length of the paper”. Other than this, “deformed folding” may also occur due to paper characteristics, etc.

Depending on the usage environment (temperature and humidity), paper type, thickness, paper grain direction, trimming accuracy, and printing states folding misalignment may occur.

⚠ CAUTION	
	Do not put fingers inside during operation.
	Keep away long hair, ties, jewelry and loose clothing.
	It could cause injury.

1-1. Adjusting folding misalignment in right and left direction

When the folded paper is misaligned along the sides, correct using the skew correction knob of the paper feed tray.

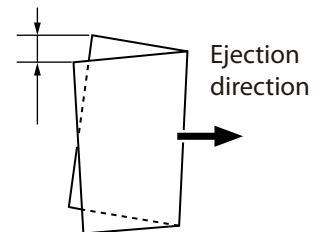

1 Check that the paper feed guides are set correctly.

Gaps between the paper and paper feed guides will cause folding misalignment along the sides to occur easily.

Proceed to step 2 if the paper feed guides are set properly.

Perform test folding after resetting the paper feed guides. Proceed to step 2 if folding misalignment occurs after setting the paper feed guides properly.

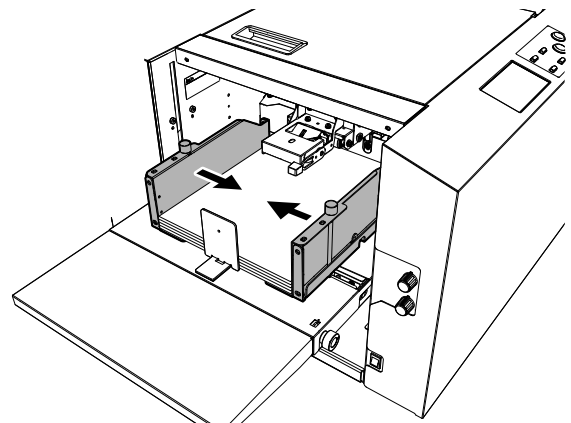

2 Remove the paper stacked on the paper feed tray.

Even if you turn the skew correction knob when the leading edge of paper is in contact with the guide plate, you cannot correct the skew.

3 Turn the skew correction knob and to correct misalignment.

Turn the skew correction knob by a quarter to half turn, then check the skew correction effect (test fold).

Folding misalignment A

Turn the knob in the clockwise direction. The leading edge of paper on the right side (on the control panel side) will be fed earlier.

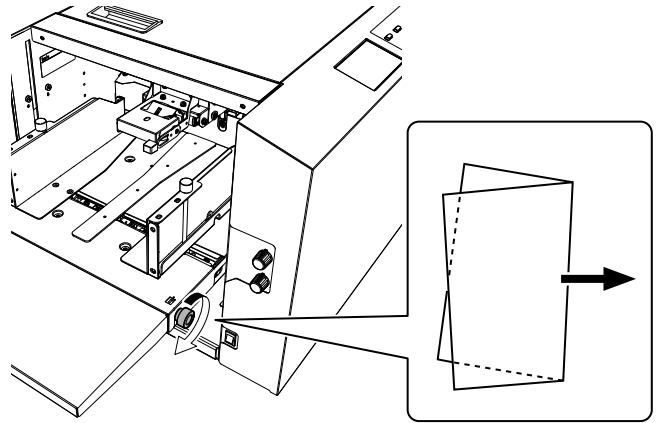

Folding misalignment B

Turn the knob in the counterclockwise direction. The leading edge of paper on the left side (on the non-operator's side) will be fed earlier.

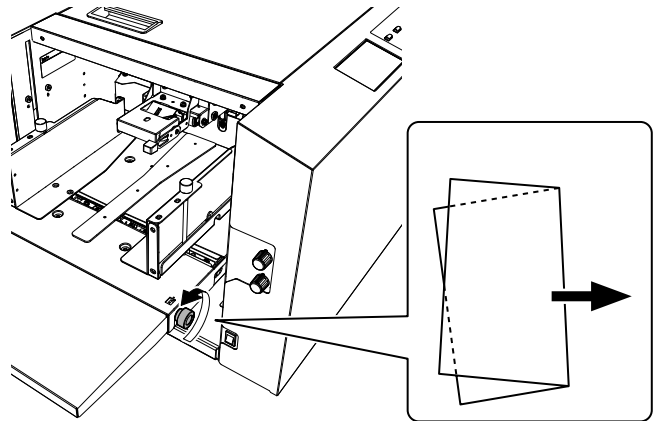

4 Stack paper on the paper feed tray.

Push in paper so that the edge of paper comes lightly in contact with the shutter.

5 Tighten the guide fixing screw on the paper feed guide.

6 Press the key to perform test folding.

7 After completing folding operations, return the skew correction knob to the standard position.

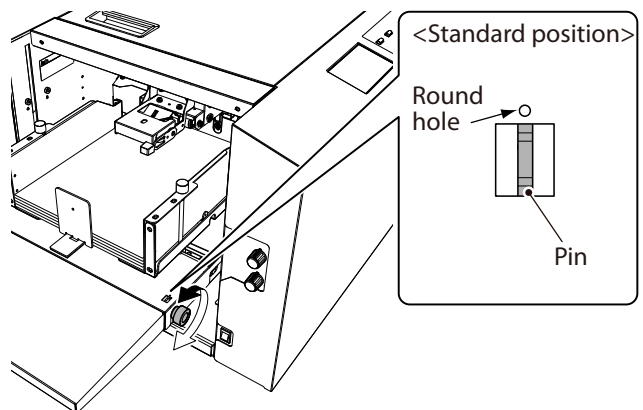

1-2. Adjusting folding misalignment in up and down direction

When the folded paper is misaligned along the vertical length, adjust the positions of the folding stopper of folding plates 1 and 2 to correct the misalignment.

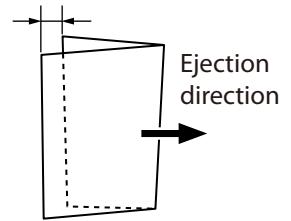

Adjustable range and correction restrictions

- Adjustable range of folding position A adjustment key/folding position B adjustment key on the [Fold Position] screen during standard folding is within ± 5.0 mm/0.20 inch.
- The positions of the folding stoppers of folding plates 1 and 2 may not be adjustable to ± 5.0 mm/0.20 inch according to the length of the paper used.
- For custom folding and [Stopper fixing mode], the folding positions are set directly according to the paper length, and the adjustable range of ± 5.0 mm/0.20 inch is not restricted.

Example: for single fold

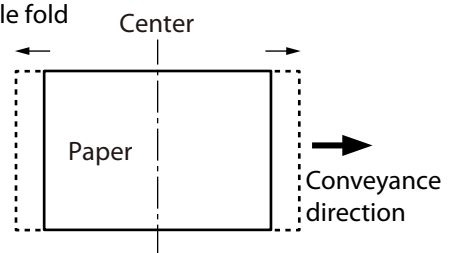

Adjustment by using the [-] key.
-5.0 mm/0.20 inch or less

Adjustment by using the [+] key.
+5.0 mm/0.20 inch or less

The restricted folding plate and adjustment details differ according to the folding mode and paper length.

Folding mode	Restricted range of paper length (*)	Restricted folding plate	Restricted adjustment key
Double fold	182.0 to 203.9 mm/7.17 to 8.03 inches	Folding plate 2	◀ key
Irregular accordion fold-out	182.0 to 182.7 mm/7.17 to 7.19 inches	Folding plate 1	▶ key
	182.0 to 199.9 mm/7.17 to 7.87 inches	Folding plate 2	▶ key
Gate fold	424.4 to 432.0 mm/16.71 to 17.00 inches	Folding plate 1	◀ key
	421.8 to 432.0 mm/16.61 to 17.00 inches	Folding plate 2	▶ key

(*) Range of paper length which cannot be corrected to ± 5.0 mm/0.20 inch. The adjustment value differs according to the paper length.

Adjustment folding misalignment along vertical length of paper by folding mode

For misalignment along the vertical length of standard folding, use the folding position A adjustment key/ folding position B adjustment key on the [Fold Position] screen to adjust.

Folding plate 1				Folding plate 2			
Folding mode		State of folded plane A	Folding A position adjustment key	Folding mode		State of folded plane B	Folding B position adjustment key
Single fold		A is long	▶ key	Single fold	Folding plate 2 is not used.		
		A is short	◀ key				

Folding plate 1				Folding plate 2			
Folding mode		State of folded plane A	Folding A position adjustment key	Folding mode		State of folded plane B	Folding B position adjustment key
Double fold	A	A is long	▶ key	Double fold	B	B is long	◀ key
		A is short	◀ key			B is short	▶ key
Irregular accordion fold-out	A	A is long	▶ key	Irregular accordion fold-out	B	B is long	▶ key
		A is short	◀ key			B is short	◀ key
Letter fold	A	A is long	▶ key	Letter fold	B	B is long	◀ key
		A is short	◀ key			B is short	▶ key
Accordion fold	A	A is long	▶ key	Accordion fold	B	B is long	▶ key
		A is short	◀ key			B is short	◀ key
Gate fold	A	A is long	▶ key	Gate fold	B	B is long	◀ key
		A is short	◀ key			B is short	▶ key

Adjustment method

Adjust the position of the folding stopper using the folding position A adjustment key/folding position B adjustment key on the [Fold Position] screen.

1 Touch the key on the [Ready] screen.

The [Fold Position] screen is displayed.

2 Adjust the folding position.

Folding stopper of folding plate 1:

- To move in the direction of [a]
Touch the ▶ key of the folding A position adjustment key.
- To move in the direction of [b]
Touch the ◀ key of the folding A position adjustment key.

Folding stopper of folding plate 2:

- To move in the direction of [c]
Touch the ◀ key of the folding B position adjustment key.
- To move in the direction of [d]
Touch the ▶ key of the folding B position adjustment key.

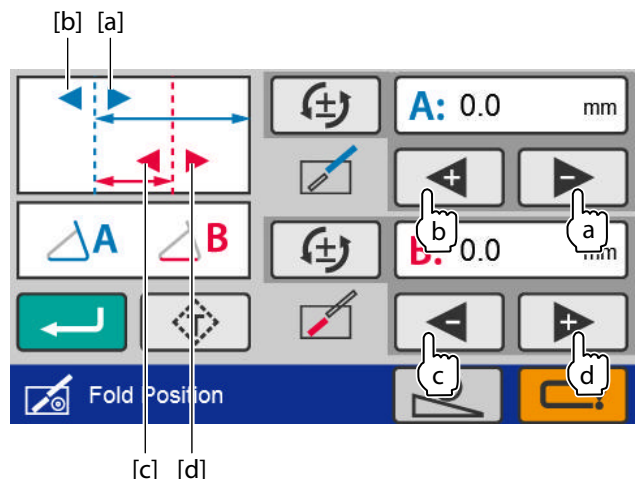





- The folding stopper moves 0.1 mm/0.004 inch each time you touch the adjustment key. Also, when you press and hold the position adjustment key, the value continues to change within the setting range of the folding stopper.
- When you input the value manually, touch [A:x.x mm] or [B:x.x mm]. The numeric keypad is displayed.

- The changed value is cleared when power is turned off. To save the changed value, see “Saving the adjusted value” (p.46).

Saving the adjusted value

If you save the adjustment value for the next time you use the same paper, you can perform folding operation under the same adjustment value as the one that is saved at this time.

- For standard folding of standard paper, touch the  key. —> Press and hold the  key to save the adjustment value.
- For standard folding or custom folding of non-standard paper, touch the  key. —> Touch the  key. —> Select and save the saved data number of custom folding. (p.46)

1-3. Deformed folding

The paper may not be folded properly due to the characteristics of paper. In such cases, check the following points.

- Do not use paper outside the specifications. Particularly, deformed folding occurs frequently in the use of thin, flimsy paper not appropriate.
- Decrease the processing speed when deformed folding occurs for thin and flimsy paper. (p.13)
- Separate paper well prior to stacking. (p.27)
- Stack paper on the paper feed tray after aligning well, and set the paper feed guides at the correct positions. Also tighten the fixing screws of the paper feed guides firmly. (p.30)

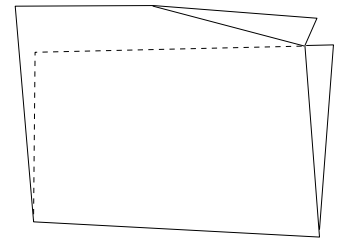

2. Standard Folding of Non-Standard Paper

Standard folding of non-standard paper is a method to perform paper folding by saving paper lengths other than standard paper and selecting the folding mode of standard folding.

Paper other than the six standard paper(*) is called non-standard paper.

(*) Five standard paper sizes For North America

The foldable sizes are as follows. (width x length)

Maximum : 311.0 x 457.2 mm/12.24 x 18.00 inches

Minimum : 120.0 x 182.0 mm/4.73 x 7.17 inches

When performing gate fold, the maximum paper length is 432.0 mm/17.00 inches.

Width :
120.0 to 311.0 mm/
4.73 to 12.24 inches

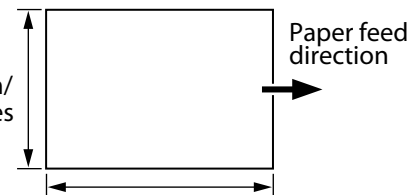



Length : 182.0 to 457.2 mm/
7.17 to 18.00 inches



- **Standard paper which is stacked on the paper feed tray in the long edge feeding direction is considered non-standard paper.**
- **The paper sizes which can be used may vary with the paper type, thickness, and printing state.**

Example: When performing letter fold on 300.0 mm/11.81 inches length paper

- 1 Touch the  key on the [Ready] screen —> Touch [STD Fold for Non-STD Size].
- 2 Using the numeric keypad, enter the paper length [300] —> Touch the  key.
- 3 Touch the  key.
Return to the [Ready] screen.

3. Custom Folding

Custom folding is an operation method to fold paper at any position by specifying the folding stopper positions (folding position) of the folding plates 1 and 2.

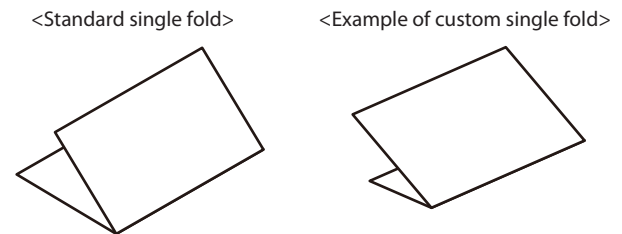

The foldable sizes are as follows. (width x length)

Maximum: 311.0 x 457.2 mm/12.24 x 18.00 inches

Minimum: 120.0 x 182.0 mm/4.73 x 7.17 inches

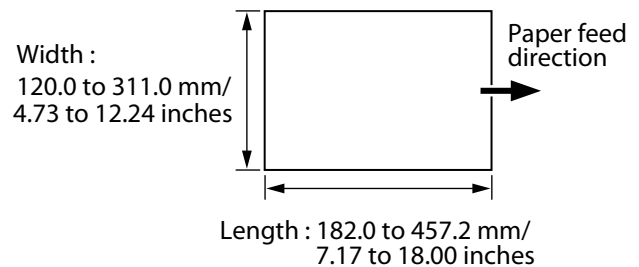

▼ The paper sizes which can be used may vary with the paper type, thickness, and printing state.

The length of the folded plane [a] which can be folded by the folding plates 1 and 2 is restricted.

Folding plate 1: 42.0 to 325.0 mm/1.65 to 12.80 inches

Folding plate 2: 0.0 (*)/47.0 to 217.0 mm
/0.0 (*)/1.85 to 8.54 inches

(*) As the folding plate 2 is not used in single folding, it is 0.0 mm/0.0 inches.

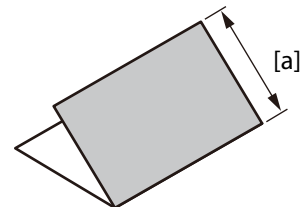

▼ Incorrectly measuring the paper length or setting the folding stopper position can cause paper jamming inside the folding plate.

3-1. Operation

As an example of accordion fold, operation procedures for custom folding are described with the following setting.

Paper size: A4 (210.0 x 297.0 mm/8.27 x 11.69 inches)

Fold A: 85.0 mm/3.35 inches (length A)

Fold B: 95.0 mm/3.74 inches (length B)

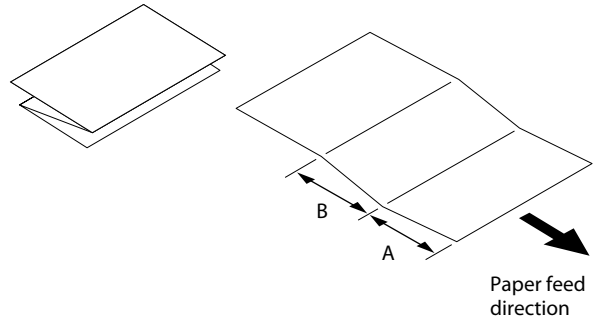

1 Prepare a folding sample manually using the paper to be folded.

2 Measure the length of the folding position of the sample.

3 Touch the  key on the [Ready] screen.

The [Paper Length] input screen is displayed.

In the [Stopper Fixed] mode, the  key is not displayed.

4 Touch the  key.

The [Create New Custom Fold] screen is displayed.

5 Touch the  key → Touch the  key.

Return to the [Create New Custom Fold] screen.

6 Touch the [A: xxxx.x mm] key → Using the numeric keypad, enter the folding A length [85] → Touch the  key.

Return to the [Create New Custom Fold] screen.

7 Touch the [B: xxxx.x mm] key → Using the numeric keypad, enter the folding B length [95] → Touch the  key.

Return to the [Create New Custom Fold] screen.

8 To save the input value, touch the  key. To continue working without saving, touch the  key.

When you touch the  key, the [Save] screen is displayed. Proceed to step 9.

When you touch the  key, the display returns to the [Ready] screen with the input value reflected.

- The input value is reflected but not saved.
- When the power is turned off without performing save operation, the input number is cleared.

You can save the data before turning off the power.

 "3-6. Directly saving folding value under processing" (p.50)

- When the stacker roller position is changed while in custom fold, the changed value is saved automatically.

9 Touch the  key.

The input value is saved, and the display returns to the [Ready] screen with the input value reflected.

The procedures taken after that will be the same as the steps 8 to 13 in Chapter 2 “3. Standard Folding of Standard Paper” (p.33).



The stacker roller position moves automatically according to the paper set.

Adjust the stacker roller position, if the paper flaps or misaligns at the time of ejection, or paper jam occurs in the paper ejecting section.

“5-2. Adjusting stacker roller position” (p.55)

3-2. Editing saved data

When the custom fold data that you want to edit is opened

- 1** Touch the key on the top screen.
The [Paper Length] input screen is displayed.
- 2** Touch the key.
When you change the paper length, input the paper length with the numeric keypad, and touch the key.
- 3** Touch [A:xxxx.x mm] or [B:xxxx.x mm] for the folding that you want to fine-adjust. —> Input the value with the numeric keypad. —> Touch the key.
Return to the [Ready] screen.
- 4** Perform step 8 to 9 in “3-1.Operation” (p.48).

When the custom fold data that you want to edit is not opened

- 1** Touch the key—> Touch [Custom Fold].
The [Custom Fold] screen is displayed.
- 2** Select the number that you want to save. —> Touch the key.
The [Edit] screen is displayed.
- 3** Perform step 3 to 4 in “When the custom fold data that you want to edit is opened” (p.49).





3-3. Using saved data

Example: When using saved data number [06]

- 1** Touch the key on the [Ready] screen —> Touch [Custom Fold].
The [Custom Fold] saved data selection screen is displayed.
- 2** Touch the key —> Touch [06] of custom fold data —> Touch the key.
The saved data number [06] is saved, and the display returns to the [Ready] screen.

3-4. Locking saved data

To prevent accidentally deleting data you want to be saved, you can lock saved data and prevent the numerical value from being changed.

- 1 Touch the  key on the [Ready] screen → Touch [Custom Fold].**
The [Custom Fold] saved data selection screen is displayed.
- 2 Select the number of the saved data you want to lock → Touch the  key.**
 is displayed on the right of the number of the saved data.
Press and hold the  key to release the lock.
- 3 Press and hold the  key.**
Return to the [Ready] screen.







Even if paper folding is being processed using the locked data, the folding position can be fine-adjusted. However, when you want to save the fine-adjusted value, release the lock.

 "3-2. Editing saved data" (p.49)



3-5. Deleting saved data

Locked saved data cannot be deleted. To delete saved data, unlock the data.

- 1 Touch the  key on the [Ready] screen → Touch [Custom Fold].**
The [Custom Fold] saved data selection screen is displayed.
- 2 Touch the  key.**
The [Save] screen is displayed.
- 3 Select the number of the saved data you want to delete → Press and hold the  key.**
Saved data is deleted.
- 4 Press and hold the  key.**
Return to the [Ready] screen.

3-6. Directly saving folding value under processing

You can save the folding status for cases such as when you want to continue operation using the same setting contents during paper folding processing. To save, perform test folding or folding processing to check folding misalignment, carry out the fine adjustments and then save.

- 1 Touch the  key on the [Ready] screen.**
The [Save] screen is displayed.
- 2 Select the number of the data you want to save → Touch the  key.**
The input value is saved and the display returns to the [Ready] screen.

4. Cross Fold

Cross fold is folding single-folded paper another time as shown in the figure.

The maximum paper thickness is fine quality paper 104.7 g/m²/71.20 lbs and coated paper 157 g/m²/106.76 lbs. Rough paper, which is thin and flimsy, is not suitable for cross fold.



- **Paper Σ dent and folding misalignment in both directions may increase or paper may be fed unstably depending on the following conditions. However, it is not a malfunction.**
 - The folded line of single-folded paper is not folded properly.
 - Usage environment (temperature and humidity)
 - Paper thickness, paper size, paper type, or paper grain direction, etc.
- **Neither the optical sensor nor the ultrasonic sensor cannot be used for cross fold. Set both of them to off.**

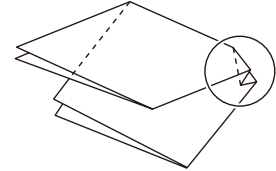

⚠ CAUTION



Do not put fingers inside during operation.



Keep away long hair, ties, jewelry and loose clothing.



It could cause injury.

4-1. Cross fold of standard paper

The following describes the cross fold of standard paper, taking cross single folding shown in the figure as an example.

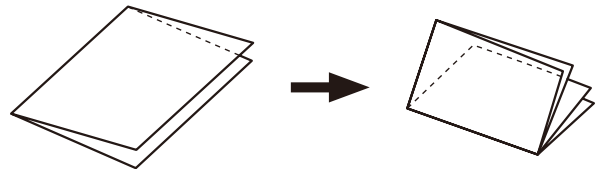

1 Single fold standard paper according to the procedure of Chapter 2 "3.Standard Folding of Standard Paper" (p.33).

2 Press the folded line of single-folded paper with the fingertip.

The paper feeding state will be unstable or paper Σ dent may be caused if the folded line of folded paper is not folded firmly.

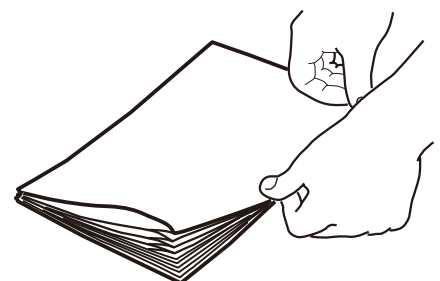

3 Loosen the guide fixing screw.

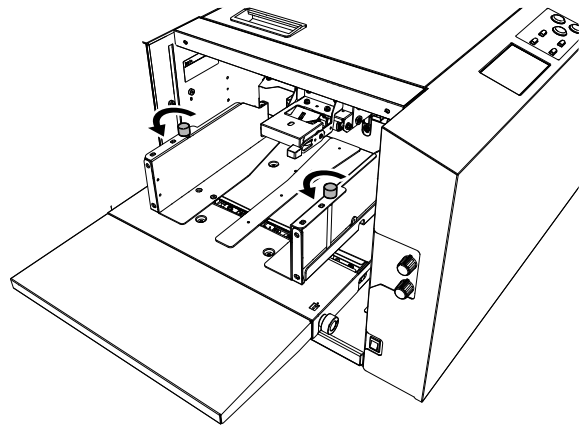

4 Stack the single-folded paper on the paper feed tray with the folded line toward the non-operator's side.

The stacking amount is equivalent to about half (25 mm/0.98 inch) [a] of the height of the paper feed guide on the folding side.

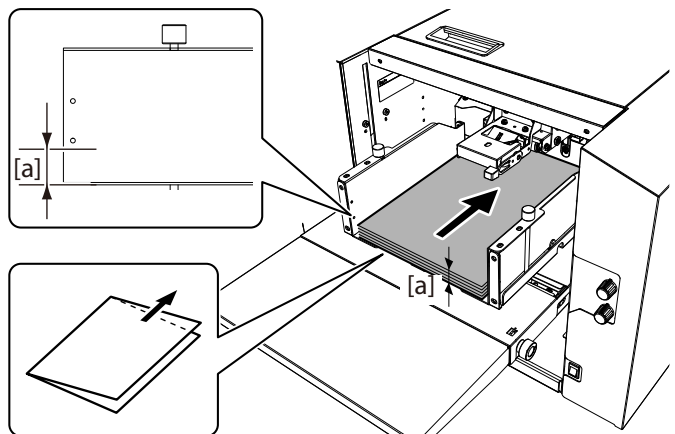

! A feed error may occur if the stacking height of single-folded paper is largely different on both sides even though the stacking height of single-folded paper is 25 mm/0.98 inch or less. If so, decrease the number of sheets stacked on the paper feed tray to reduce the difference on both sides of paper.

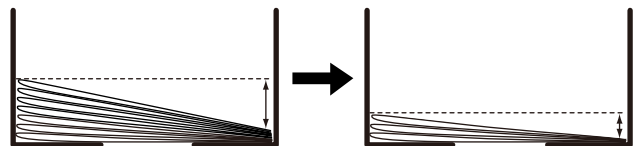

5 Attach the paper feed guide lightly to the side of the paper and tighten the fixing screws.

6 Set the trail edge guide unit to the rear end of paper.

The trail edge guide unit must be set slightly apart from the paper.

7 Set the air volume of [Separating Air], [Pickup Air] and [Side Air] on the [Air Adjust] screen.

Set the air volume referring to "Air Adjustment Table" (p.39) to the set numerical value + [5].

8 Set the separating air adjustment knob to [2].

9 Set the separator adjustment knob to [3].

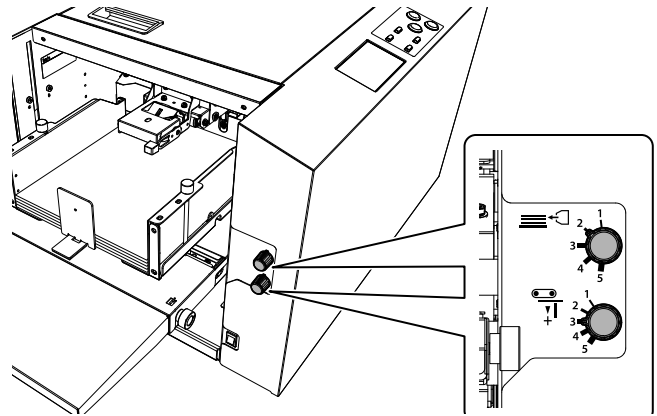

10 Set the stack height sensor adjustment knob to the scale between the first one and second one.

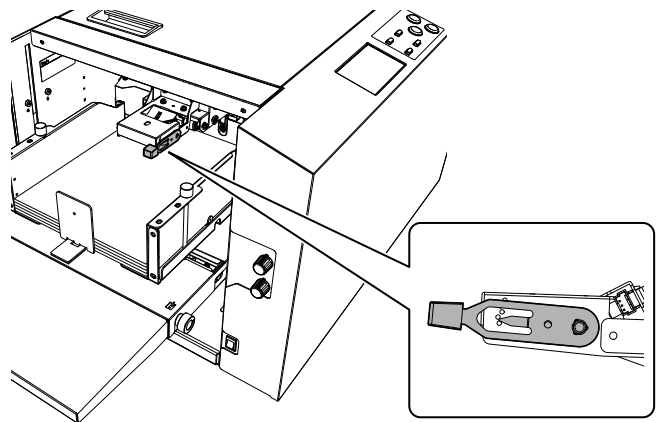

11 Touch the  or  key on the [Ready] screen to set the speed to .

Set the processing speed for cross fold to  or less. If the processing speed exceeds, paper jam may occur depending on the paper size.

12 Check that both the optical sensor and the ultrasonic sensor in [D-Feed] is set to off. (p.61)

13 Check that [Feed Interval] is set to [Normal]. (p.63)

Set [Feed Interval] to [Slow] when mis-feed occurs during folding operation of thick paper.



14 Touch the  key on the [Ready] screen —> Touch the  key.

Return to the [Ready] screen.

15 Press the  key to test fold.

16 Check the finish.

4-2. Cross fold of non-standard paper

- 1 Single fold non-standard paper according to the procedure of "2.Standard Folding of Non-Standard Paper" (p.46).
- 2 Measure the length of the finished single folded paper [a].
- 3 Touch the  key on the [Ready] screen → Touch [Standard Fold for Non-Standard Size].
- 4 Using the numeric keypad, enter the paper length → Touch the  key.
- 5 Touch the  key.
Return to the [Ready] screen.
- 6 Perform steps 2 to 16 in "4-1. Cross fold of standard paper" (p.51).

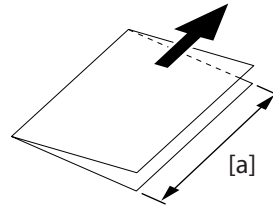

4-3. Cross fold paper at desired folding position

Cross folding is a method to cross fold standard paper and non-standard paper at the desired folding position. Standard paper is handled the same as non-standard paper and is operated in a method that saves the folding position on the custom fold.

- 1 Save the custom fold using the procedure in "3. Custom Folding" (p.47).
- 2 Single-fold the paper in the custom folding mode.
- 3 Again, save the custom fold of the single folded paper using the procedure in "3. Custom Folding" (p.47).
- 4 Perform steps 2 to 16 in "4-1. Cross fold of standard paper" (p.51).

5. Stacker Roller Adjustment

5-1. Changing stacker roller height

Some thick and stiff paper may not be ejected smoothly because the paper may open after folding. Change the stacker roller height and widen the space for the paper to pass in ejection.

- 1 Remove the auxiliary paper ejection guide.
- 2 Lift the stacker roller and hold it with hand to move to the [a] position shown in the figure.

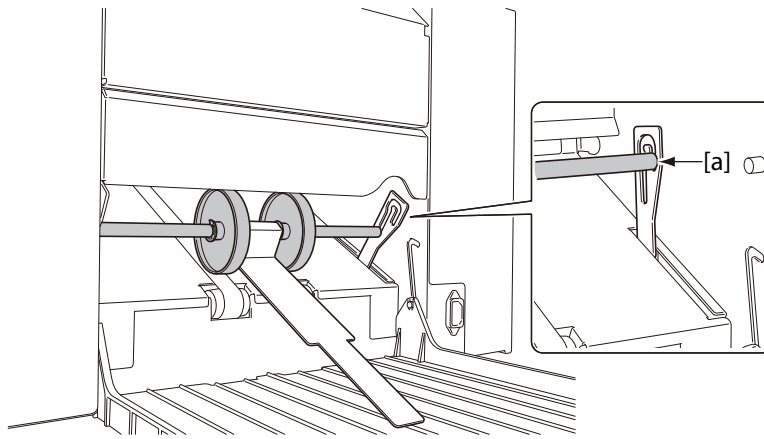

! After completing folding operations, be sure to return the stacker roller to the standard position. Leaving it in the raised state will result in poor alignment of ejected paper.

5-2. Adjusting stacker roller position

The position of the stacker roller is set automatically to match the paper size and folding mode. However, change the position if thick paper or paper processed in cross fold tends to unfold, stack unevenly, or jam on ejection.

! Do not move the stacker roller forcibly back or forth by hand. The machine may be broken by doing so.

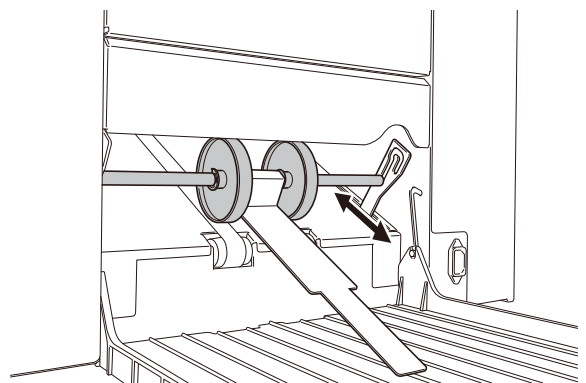

Guide for the setting position of stacker roller

Settings	Applicable standard paper size and folding mode			
	For EU		For North America	
1	B5	Double fold	STMT, INV	Double fold, Letter fold, Accordion fold
	A5	Double fold, Letter fold, Accordion fold		
	B6	Double fold, Letter fold, Accordion fold, Gate fold		
3	A4	Double fold	LTR	Double fold
	B5	Accordion fold, Gate fold		
	A5	Gate fold		
5	A3, B4	Double fold	STMT, INV	Single fold, Irregular accordion fold-out, Gate fold
	A4	Letter fold, Accordion fold	LTR	Letter fold, Accordion fold
	B5	Letter fold	LGL, LGR	Double fold
	A5, B6	Single fold, Irregular accordion fold-out		
7	A4	Gate fold		
8			LTR	Gate fold
9	B4	Letter fold, Accordion fold	LGL	Letter fold, Accordion fold
	B5	Single fold, Irregular accordion fold-out		
11	A3	Letter fold, Accordion fold	LTR	Single fold, Irregular accordion fold-out
	A4	Single fold, Irregular accordion fold-out	LGR	Letter fold, Accordion fold
15	A3, B4	Single fold, Irregular accordion fold-out, Gate fold	LGL, LGR	Single fold, Irregular accordion fold-out, Gate fold

1 Touch the  key on the [Ready] screen.

The [Fold Position] screen is displayed.

2 Touch the  key.

The [Stacker Roller] screen is displayed.

3 Using the [+]/[-] keys, adjust the position of the stacker roller.

The smaller the value becomes, the more the position of the stacker roller moves to the internal side of the machine. The higher the value, the more it moves to the outer side of the machine.

4 Touch the  key.

Paper for test folding is not counted as the number of processed sheets.

5 Touch the  key.

Return to the [Fold Position] screen.

6 Touch the  key.

Return to the [Ready] screen.

When the paper size or folding mode is changed, the changed value is cleared.

When the paper size is changed by automatic paper size detection, the value is not cleared.

When sheets of paper folded in the gate fold mode, a sheet processed later slips into the one processed before:

Depending on the type and size of paper, the adjustable range in the gate fold mode is limited. Be sure to decrease the setting values one scale at a time in this mode and check the results.

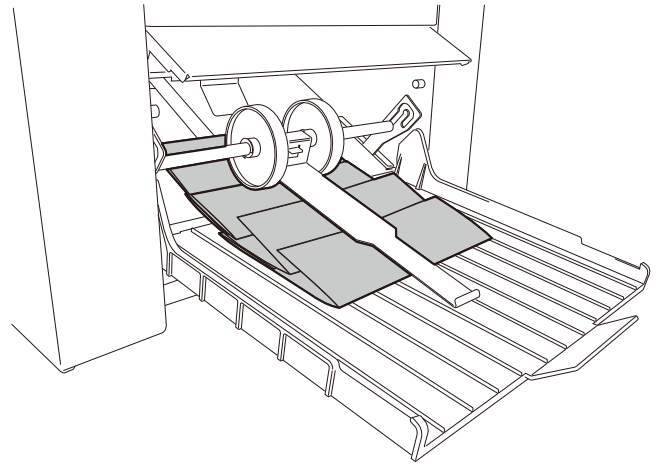

6. Stacking Folded Paper

The angle of the paper receiving tray of this machine can be changed. If the angle is changed, the folded paper can be stacked in the following two ways according to the purpose.

Diagonal stacking [a]: Basic paper stacking method

Straight stacking [b]: Used when paper jams at the ejecting section.

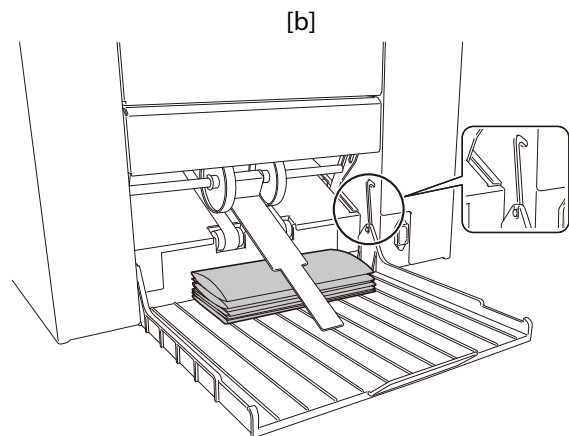
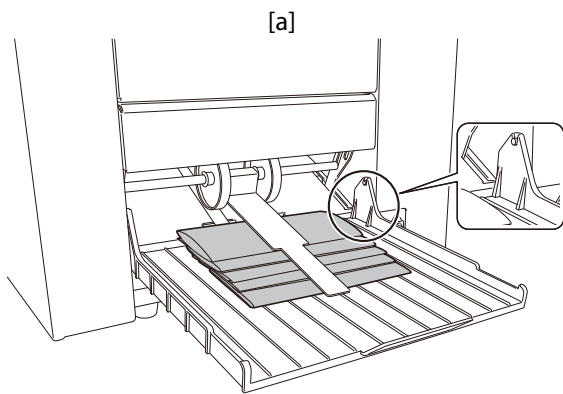

7. Adjusting Spring Pressure

When feeding thick paper or slippery paper, the paper may stop at the conveyance roller without reaching to the folding roller. In this case, increase the spring pressure for the conveyance roller.

On the other hand, when feeding thin paper or flimsy paper, the paper may get wrinkled lengthways. In this case, decrease the spring pressure for the conveyance roller.

- ! • **When adjusting the spring pressure, turn off the machine.**
- **When adjusting the spring pressure, be careful not to harm your hand.**

There are two springs on the operator's side and the non-operator's side. The standard position is as shown in the figure.

- ! **The position of the spring must be the same on the operator's side and non-operator's side. Otherwise, folding misalignment may occur.**

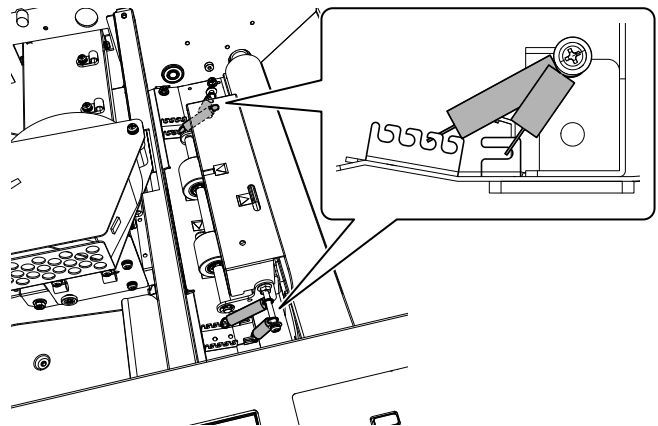

Adjust the spring pressure in the following procedures.

1 Adjust the spring pressure by changing the position of the spring located inside.

The closer the hooked position is to the paper feed section [a], the higher the pressure is.

The closer the hooked position [b] to the ejecting section, the lower the pressure is.

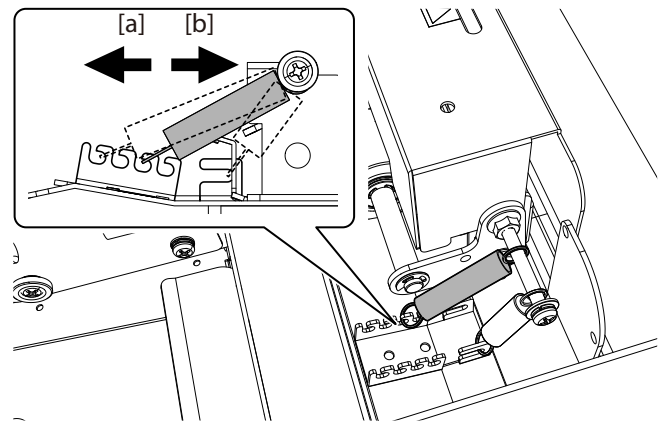

2 To further increase the spring pressure, hook the spring closer to the paper feed section.



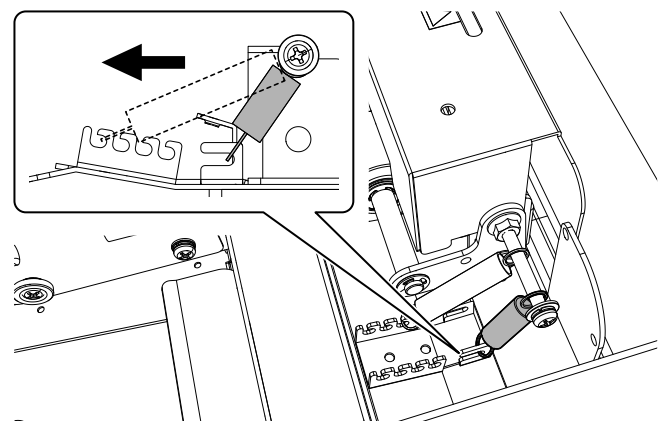

- If the spring pressure is too high, paper may get wrinkled.
- If the spring pressure is too low, paper may not be conveyed.

After paper feed is finished or before feeding other paper, return each spring to the standard position.



8. Function Settings

The function settings screen is used to set detecting functions such as double-feed, paper feed interval and buzzer sounds according to paper used and operation environment.

On the function settings screen, the functions of the  (Return) key and  (Cancel) key are as follows.



 : Confirms the setting and returns to the [Function Settings] screen.

 : Returns to the [Function Settings] screen without saving the input content. Press and hold the key to return to the [Ready] screen.

If those keys function otherwise, the function will be mentioned individually.

8-1. Thin paper mode

Use the thin paper mode when handling thin and flimsy paper such as rough paper and recycled paper. Do not use for the paper other than thin type. When using this mode for the paper type other than thin paper, paper jam may occur.

- 1 Touch the  key on the [Ready] screen → Change the processing speed to .
Touch the  key to clear the thin paper mode.



8-2. Interval function

Interval (suspension) function is a function to specify the number of sheets to be folded and suspend folded paper by interrupting paper folding operation for a certain period of time.

Take out ejected paper during interruption, and another operation after paper folding such as distribution or enclosure can be prepared.

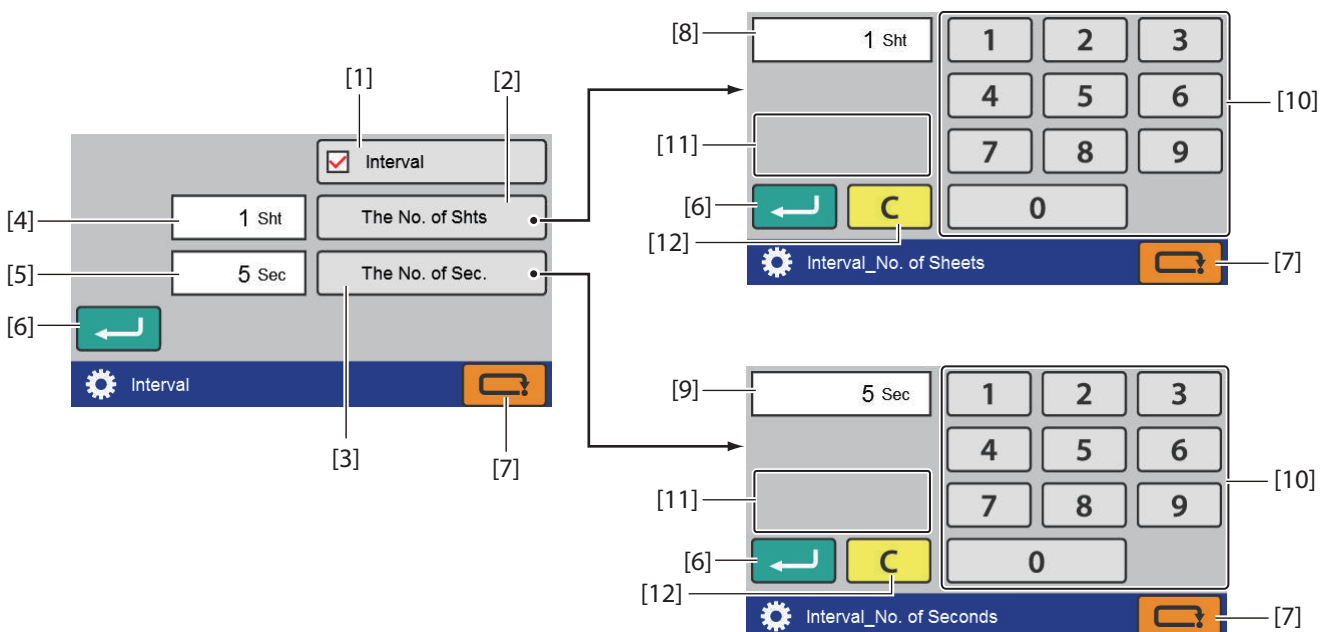
- 1 Touch the  key on the [Ready] screen → Touch the  key → Touch [Interval].
The [Interval] screen is displayed.



No.	Name	Function	Default value
[1]	Interval	Sets on/off of the interval function.	—
[2]	No. of Sheet	The [Interval_No. of Sheets] screen is displayed. When the interval setting is turned off, the key is grayed out and cannot be operated. Setting range: 1 to 999 (sheets)	1
[3]	The No. of Sec.	The [Interval_No. of Seconds] screen is displayed. When the interval setting is turned off, the key is grayed out and cannot be operated. Setting range: 3 to 30 (seconds)	5
[4]	Interval_No. of Sheets setting value	Displays the currently set interval sheets number.	—
[5]	Interval_No. of Seconds setting value	Displays the currently set interval time.	—
[6]	 (Return) key	[Interval] screen Saves the on/off setting of the interval and returns to the [Function Settings] screen. [Interval_No. of Sheets] screen/[Interval_No. of Seconds] screen Saves the input value and returns to the [Interval] screen.	—
[7]	 (Cancel) key	[Interval] screen Returns to the [Function Settings] screen without saving the input content. [Interval_No. of Sheets] screen/[Interval_No. of Seconds] screen Returns to the [Interval] screen without saving the input value. Press and hold to return to the [Ready] screen.	—
[8]	Interval sheet number input value	Displays the input value.	—
[9]	Interval time input value		
[10]	Numeric keypad	Inputs the value.	—
[11]	Input range display.	Displayed when trying to input a value outside the input range.	—
[12]	 (Clear) key	Sets the input value to "0."	—

After setting, an icon () is displayed on the touch panel display section.



8-3. Double-feed detection

Double-feed detection refers to a function that reads the thickness of paper on test folding and detects when more than one sheet of paper is fed into the machine at a time.

When the ultrasonic sensor is set, there is no need to perform test folding.

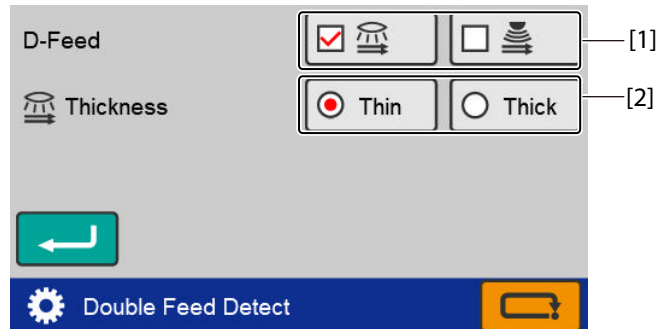

- 1 Touch the  key on the top screen → Touch the  key → Touch [D-Feed Detect].
The [Double Feed Detect] screen is displayed.



No.	Name	Function	Default value
[1]	D-Feed Detect	Sets whether to enable double-feed detection. When the DF ULTRASONIC SENSOR KIT is not registered, on/off can be changed with the checkbox.  Enables the optical sensor.  Enables the ultrasonic sensor.	—
[2]	Thickness	When the optical sensor is set for double-feed detection, set the thickness of the paper. When the ultrasonic sensor is selected, the key is grayed out and cannot be operated.	Thin

After setting, an icon is displayed on the touch panel display section.

When the optical sensor is enabled

- Set the paper [Thickness] to [Thin] when normal operation is performed.
If a double-feed is wrongly detected though the paper thickness is set to [Thin] and no double-feed occurs in test folding or normal operation, set to [Thick].
- Perform test folding before you start processing paper folding.
The machine will not start if test folding is not performed even when the  key is pressed.
When test folding is performed, the icon changes from  to .
- The data on paper thickness read by test folding will be cleared by changing the [Thickness] in the double-feed detection setting. Test fold again when the setting is changed.



- **Be sure to perform test folding every time printing materials are changed to different ones even if the quality and thickness of paper used are the same. Double-feed may not be detected correctly if processing is started without test folding.**
- **Double-feed detection may not work properly if printing on paper is uneven or paper is misaligned.**
- **When [D-Feed Detect] is set to on, if double-feed occurs on test folding, perform test folding again. Otherwise, double-feed will not be detected properly.**

When mis-detection occurs

Double-feed or miss-feed may sometimes be detected although the paper is fed normally.

- If false double-feed detection occurs when paper thickness is set to [Thin], repeat test folding after setting paper thickness to [Thick].
If double-feed is detected mistakenly after selecting [Thick], double-feed detection function cannot be used. Set the double-feed detection to off.
- If false miss-feeding detection occurs when paper thickness is set to [Thick], repeat test folding after setting paper thickness to [Thin].
If mis-feed is detected mistakenly after selecting [Thin], double-feed detection function cannot be used. Set the double-feed detection to off.



8-4. Detection

If [Paper Empty] is displayed even though paper is stacked in the paper feed tray, turn off paper detection. This setting turns back on when the power is turned off.

If a detection error persists even after performing cleaning of the sensor, contact your dealer.

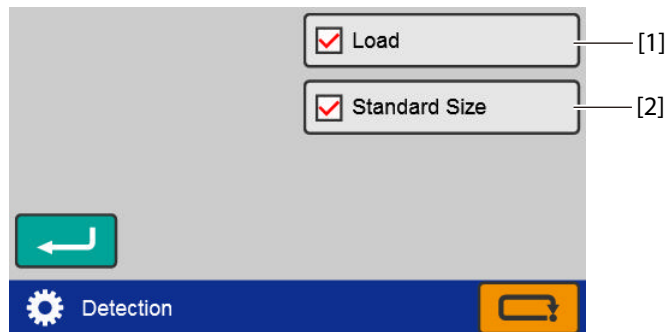
- 1 Touch the  key on the [Ready] screen → Touch the  key → Touch [Detection].
The [Detection] screen is displayed.



No.	Name	Function	Default value
[1]	Load	Sets on/off of paper stack detection of the paper feed tray. When the paper stack detection is turned off, the paper feed tray descends after the machine stops. Touch the  key or the  key to raise the paper feed tray.	On
[2]	Standard Size	Sets on/off of automatic standard size detection. When automatic detection is turned off, you must select the paper size manually.	On

8-5. Paper feed interval time

Paper feed interval is a paper feed time lag between one sheet and the next sheet. Set the feed interval to [Slow] if [Feed Err Misfeed] occurs with thick, heavy paper even after air volume, etc. has been adjusted. Setting the feed interval to [Fast] will raise processing performance, but feed error may be more likely to occur with large sheets of paper such as B4, A3, etc.

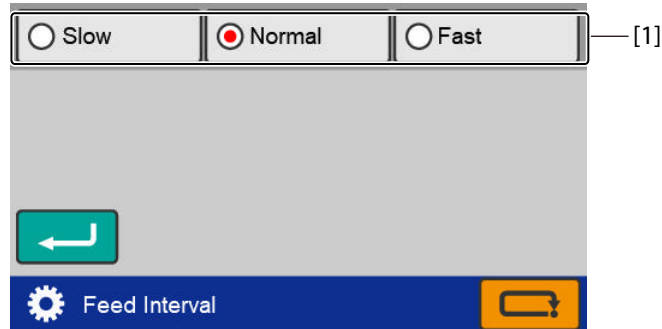

No.	Name	Function	Default value
[1]	Feed Interval	Sets the paper feed interval.	Normal

1 Touch the  key on the [Ready] screen → Touch the  key → Touch [Feed Interval].

The [Feed Interval] screen is displayed.

8-6. Belt conveyance volume

Set the ejection conveyance amount to [Large] if double folded thick paper tends to unfold on ejection, stack unevenly, or jam at the paper ejecting section.

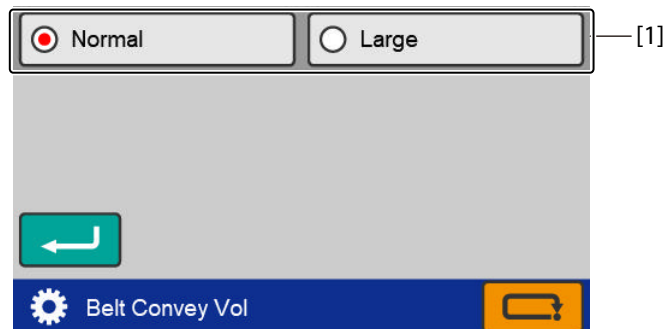

No.	Name	Function	Default value
[1]	Belt Convey Vol	Sets the belt conveyance volume	Normal

1 Touch the  key on the [Ready] screen —> Touch the  key —> Touch [Belt Convey Vol].



The [Belt Convey Vol] screen is displayed.



[Belt Convey Vol] is not reset until the power is turned off. However, it returns to [Normal] under the following conditions.

- When folding mode is changed from custom folding to standard folding.
- When turning off the machine with [Oper Mode] set to [Normal].

8-7. Idling

When double-feed or mis-feed occurs, or when stopping paper folding operations by pressing the  key, you can put the machine in the idling state by just stopping feeding operations. To resume paper feed, just press the  key.

1 Touch the  key on the [Ready] screen —> Touch the  key —> Touch the  key —> Touch [Idling].

The [Idling] screen is displayed.



No.	Name	Function	Default value
[1]	Idling	Sets on/off of idling.	Off



The machine will resume paper feed when the control panel is not operated more than 30 seconds in the idling state.

Press the  key to stop the machine during idling.

8-8. Tray descend amount

You can specify the descend amount of paper feed tray when pressing the  key during paper feed or operations.

- 1 Touch the  key on the [Ready] screen → Touch the  key → Touch the  key → Touch [Tray Desc Amount].

The [Tray Desc Amount] screen is displayed.

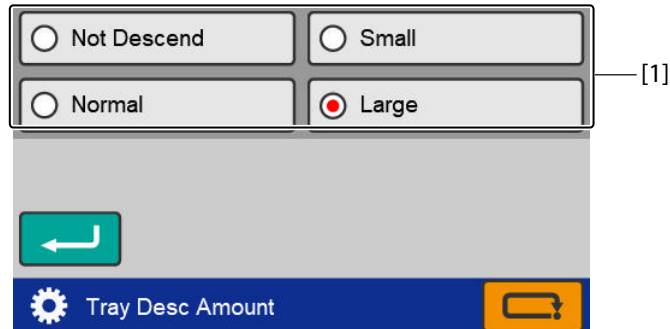

No.	Name	Function	Default value
[1]	Tray Desc Amount	<p>[Large]: descends to the lower limit.</p> <p>[Normal]: descends about 30 mm/1.18 inches from the paper feed tray stop position.</p> <p>[Small]: descends about 20 mm/0.79 inch from the paper feed tray stop position.</p> <p>[Not Descend]: remains at the paper feed tray stop position.</p>	Large



It is recommended to set the paper feed tray descent distance to [Large]. When the descend distance is decreased by selecting [Not Descend] or [Small], paper may be put on the paper detection sensor depending on paper thickness or paper stack height, double-feed may occur when paper is put on the sensor and re-fed.

If you have decreased the tray descend amount, remove paper on the paper feed tray and load it again, then feed paper.

When there is no paper on the paper feed tray, [Large] is selected regardless of the setting.

8-9. Tone

The on/off of the buzzer (key operational sound on the control panel) can be set. The buzzer sounds with the setting off when a trouble has occurred.

- 1 Touch the  key on the top screen → Touch the  key → Touch the  key → Touch [Tone].

The [Tone] screen is displayed.

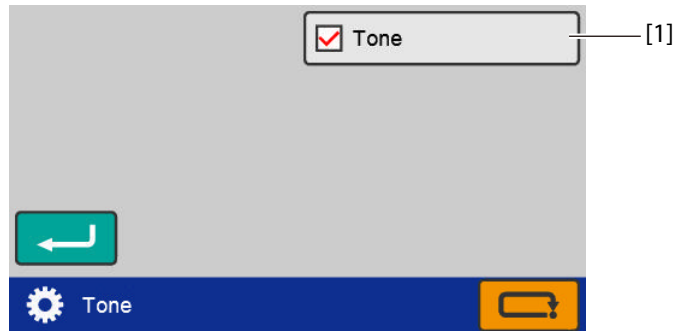

No.	Name	Function	Default value
[1]	Tone	Sets on/off of the tone.	On

8-10. LCD bright

Set the brightness of the backlight of the LCD touch panel section.

- 1 Touch the  key on the [Ready] screen → Touch the  key → Touch the  key → Touch [LCD Bright].

The [LCD Bright] screen is displayed.

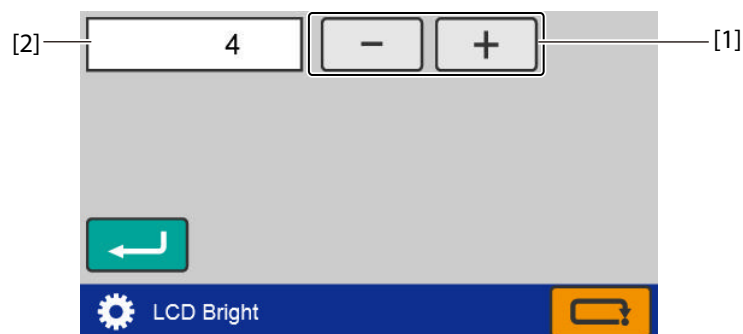

No.	Name	Function	Default value
[1]	Screen brightness adjustment key	Sets the brightness of the backlight. [+]: Makes the screen brighter. When the set value is at the upper limit, the key is grayed out and cannot be operated. [-]: Makes the screen dimmer. When the set value is at the lower limit, the key is grayed out and cannot be operated. Setting range: 1 to 5	4
[2]	Screen brightness display	Displays the values currently set.	—

8-11. Number of test sheets

The number of sheets is set when performing test feeding.

- 1 Touch the  key on the [Ready] screen → Touch the  key → Touch the  key → Touch [Number of Test Sheets].

The [Number of Test Sheets] screen is displayed.

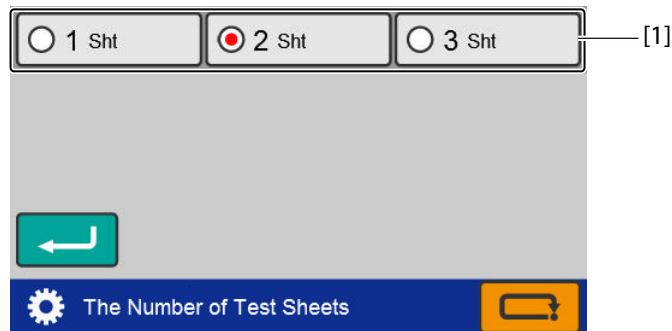

No.	Name	Function	Default value
[1]	Number of test sheets setting	Sets the number of test feed sheets. Setting range: 1 to 3	2

8-12. Language



Changes the language displayed on the touch panel.

- 1 Touch the  key on the [Ready] screen → Touch the  key → Touch the  key → Touch [Language].

The [Language] screen is displayed.



No.	Name	Function	Default value
[1]	Select the language	Selects the language displayed on the touch panel.	English

No.	Name	Function	Default value
[2]	 (Return) key	Saves the number of test sheets setting and returns to the [Function Settings] screen. When <input type="checkbox"/> アイコン表示 is turned off, the text keys are displayed in the [Ready] screen. When <input type="checkbox"/> アイコン表示 is turned on, the icon keys are displayed. The <input type="checkbox"/> アイコン表示 on/off function is only for Japanese mode. If you select any language other than <input type="radio"/> 日本語, <input type="checkbox"/> アイコン表示 becomes hidden.	—
[3]	 (Cancel) key	Returns to the [Function Settings] screen without saving the input content. Press and hold to return to the [Ready] screen.	—

8-13. Power saving

Set the time for the backlight of the LCD touch panel section to automatically turn off when the machine is not used for a certain time.

- 1** Touch the  key on the [Ready] screen → Touch the  key → Touch the  key → Touch [Power Save].

The [Power Save] screen is displayed.

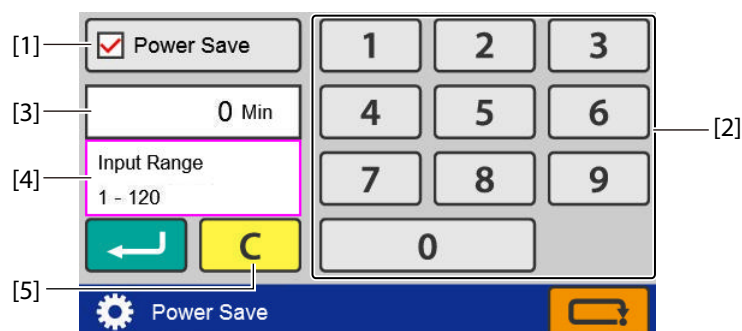

No.	Name	Function	Default value
[1]	Power Save	Set on/off of the power saving function.	On
[2]	Numeric keypad	Inputs the value. When the power saving setting is turned off, the key is grayed out and cannot be operated. Input range: 1 to 120 (minutes)	1
[3]	Power saving time display	Displays the time currently set.	—
[4]	Input range display.	Displayed when trying to input a value that exceeds the input range.	—
[5]	 (Clear) key	Sets the input value to "0". When the power saving setting is turned off, the key is grayed out and cannot be operated.	—

8-14. Alarm

When this machine remains unused for the specified period of time, the buzzer sounds to remind that the power remains turned on.

When the machine is not operated after the alarm sounds, the alarm will continue to sound every 1 minute.

- 1** Touch the  key on the [Ready] screen → Touch the  key → Touch the  key → Touch [Alarm].

The [Alarm] screen is displayed.

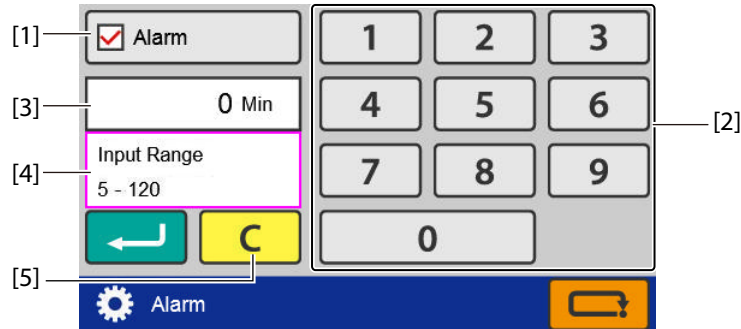

No.	Name	Function	Default value
[1]	Alarm	Set on/off of the alarm.	Off
[2]	Numeric keypad	Inputs the value. When the alarm setting is turned off, the key is grayed out and cannot be operated. Input range: 5 to 120 (minutes)	60
[3]	Alarm time display	Displays the time currently set.	—
[4]	Input range display	Displayed when trying to input a value that exceeds the input range.	—
[5]	 (Clear) key	Sets the input value to "0". When the alarm setting is turned off, the key is grayed out and cannot be operated.	—

8-15. Operation mode when turned on



Set the state of the following functions when the power is turned on.

- Operation mode
- Double-feed detection
- Interval
- Processing speed

1 Touch the  key on the top screen → Touch the  key → Touch [When Turned On].

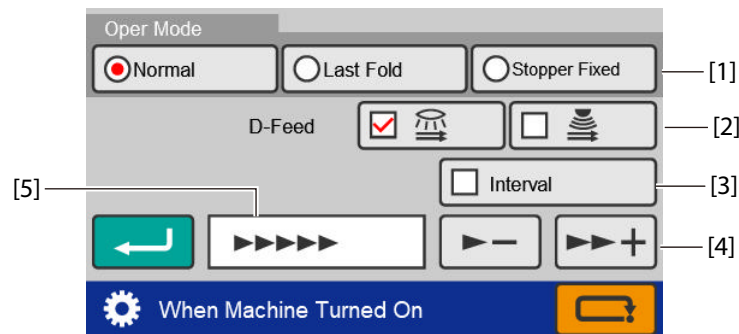
The [When Turned On] screen is displayed.



No.	Name	Function	Default value
[1]	Oper Mode	<p>Set the movement of the folding stopper for the folding plates 1 and 2.</p> <p>[Normal]: When the power is turned on, the machine starts up in the state specified on the [Initial Screen] screen.</p> <p>[Last Fold]: When the power is turned on, the machine starts up with the settings and the counter of the last time the machine was used in effect. However, [Detection] starts up set as turned on, and the adjustment value of the folding plates 1 and 2 return to the initial value when not saved.</p> <p>After setting, an icon () is displayed on the touch panel display section.</p> <p>[Stopper Fixed]: The settings of the control panel can be omitted when folding is always performed in the same conditions. When [Stopper Fixed] set to on, the machine starts up in the following states.</p> <ul style="list-style-type: none"> • The machine is always automatically set to the same conditions when the power is turned on and initial operation of folding plate is no longer performed. • The folding mode or paper size cannot be changed on the [Basic Settings] screen. • [Standard Size] in [Detection] is automatically set to off. • The adjustment value of the folding plates 1 and 2 returns to the initial value when it is not saved. • After setting, an icon () is displayed on the touch panel display section. 	Normal
[2]	D-Feed	Specify double-detection method (optical sensor or ultrasonic sensor) when turned on with [Oper Mode] set to [Normal].	Off

No.	Name	Function	Default value
[3]	Interval	Sets whether to enable the interval.	Off
[4]	Processing speed up/down key	Sets the processing speed when turned on with [Oper Mode] set to [Normal].	—
[5]	Processing speed display	Displays the processing speed currently set.	—

⚠ When [Stopper Fixed] is set to on, folding misalignment in the vertical direction occurs by removing the folding plate with the power turned off. Be sure to press the $\checkmark/\&\rightarrow$ key at the same time when turning on the power, and eject the folding plate forcibly.

8-16. Initial screen

You can set the desired screen when the power is turned on according to the work situation.

1 Touch the  key on the [Ready] screen → Touch the  key → Touch [Initial Screen].

The [Initial Screen] screen is displayed.

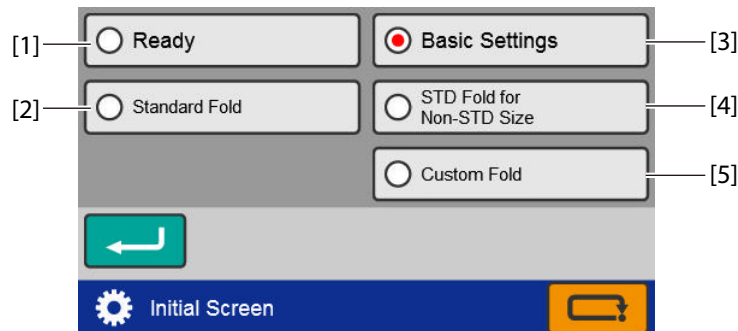

No.	Name	Function	Default value
[1]	Ready	Sets the displayed screen when power is turned on to the [Ready] screen.	—
[2]	Standard Fold	Sets the displayed screen when power is turned on to the [Folding Mode] screen. Sets the displayed screen when power is turned on to the [Standard Size] screen.	—
[3]	Basic Settings	Sets the displayed screen when power is turned on to the [Basic Settings] screen.	—
[4]	STD Fold for Non-STD Size	Sets the displayed screen when power is turned on to the [Paper Length] input screen.	—
[5]	Custom Fold	Sets the displayed screen when power is turned on to the [Custom Fold] screen.	—

8-17. Custom screen

You can add custom keys to display the screen you want to move immediately to from the top screen. However, the screen is not displayed when stopper fixed mode is set.

- 1 Touch the  key on the [Ready] screen —> Touch the  key —> Touch [Custom Screen].

The [Custom Screen] screen is displayed.

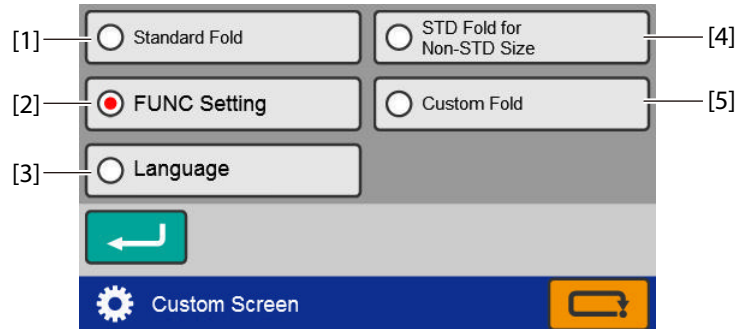

No.	Name	Function	Default value
[1]	Standard Fold (*1)	The [Folding Mode] screen of [Standard Fold] is displayed. However, when automatic paper size detection is turned off, the [Standard Size] screen is displayed.	—
[2]	Function Settings (*1)	The [Function Settings] screen is displayed.	—
[3]	Language (*2)	The [Language] setting screen is displayed. Chose your language.	—
[4]	STD Fold for Non-STD Size (*1)	The [Paper Length] input screen of [Standard Fold for Non-Standard Size] is displayed.	—
[5]	Custom Fold (*1)	The saved data selection screen of [Custom Fold] is displayed.	—

(*1) The screen is not displayed when the machine is set to [Stopper Fixed].

(*2) This screen is displayed in any setting modes.

8-18. mm/inch

According to the usage environment, units of numerical input saved for the paper size, folding dimensions (folding stopper adjustment value), and custom folding can be changed.

- 1 Touch the  key on the [Ready] screen → Touch the  key → Touch the  key → Touch [mm/inch].

The [mm/inch] screen is displayed.

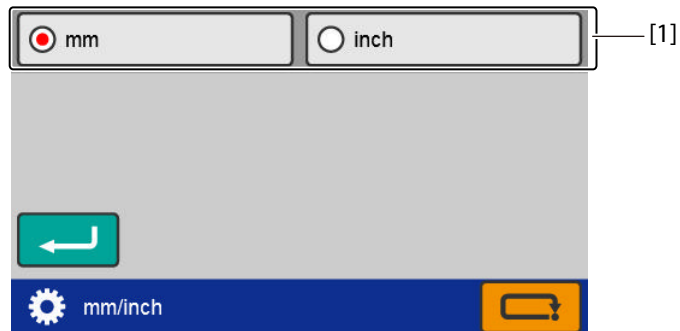

No.	Name	Function	Default value
[1]	mm/inch	Sets the display unit of the dimension values.	mm (For EU) inch (For North America)

Chapter 4 Maintaining the Machine

- ! • Make sure that you disconnect the power cord from the wall outlet before cleaning.
- Before you use the machine after cleaning, make sure that its surface is completely dry.

! CAUTION



Do not use flammable sprays and solvents during cleaning, etc. of internal parts of the machine and in the vicinity of the machine.



Doing so could cause build-up of gas inside the machine, which in turn could cause ignition, resulting in fire and explosion.



When using alcohol, exercise precaution against fire and ventilate well, and after use, store in a safe place.

Use of other solvents may damage the rubber rollers and resin inside the machine, resulting in malfunction.

1. Cleaning folding roller and conveyance roller

1 Remove the folding plate 1.

- ! Attach the folding plate 1 holding with both hands.

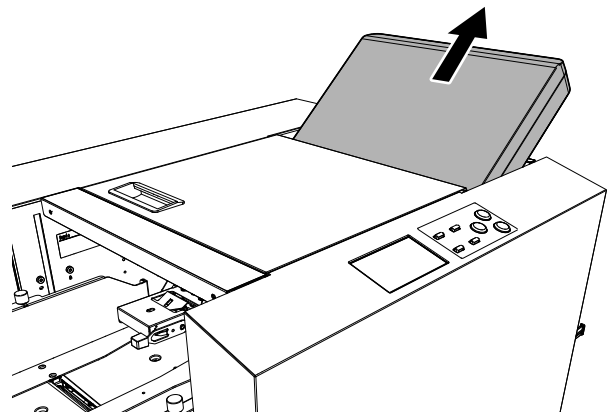

2 Open the top cover.

! CAUTION



Open or close the top cover gently.

Hands or fingers may be caught in the cover section. Doing so may result in injury.

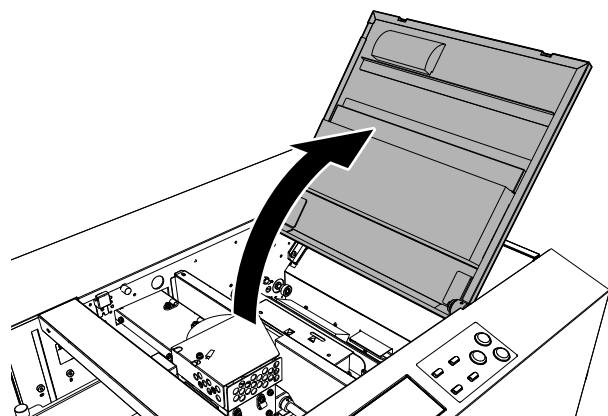

- 3** Wipe with a cloth moistened with alcohol, while rotating the jam correction knob on the folding roller by hand. [a]
- 4** Wipe the conveyance roller with a cloth moistened with alcohol while rotating it by hand. [b]

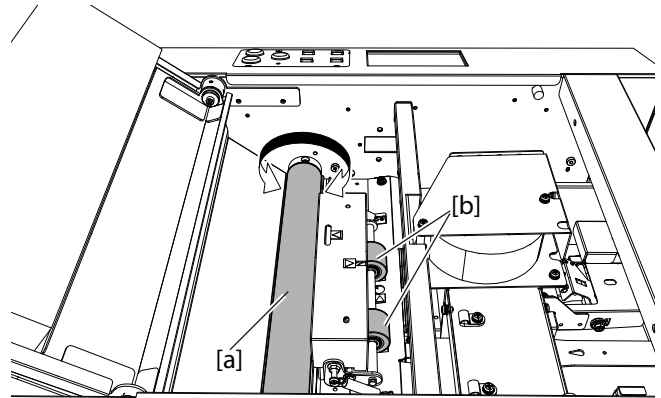

2. Cleaning LCD

Wipe the LCD on the control panel with the dry cloth.

3. Cleaning belts

Suction belt

- 1** Wipe the belt with a cloth moistened with alcohol while rotating it by hand.

⚠ Make sure that the cloth does not get caught on the sensor lever.

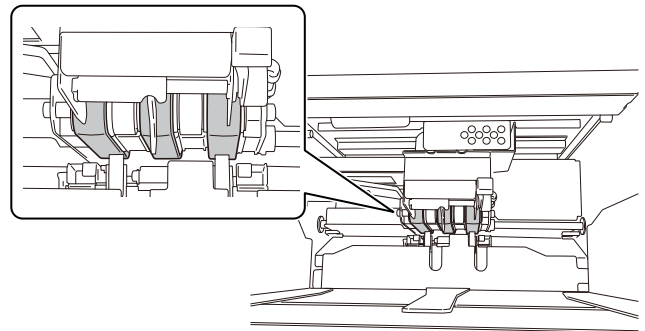

Stacker belt

- 1** Remove the auxiliary paper ejection guide.
- 2** Wipe the stacker belt with a cloth moistened with alcohol while rotating it by hand.

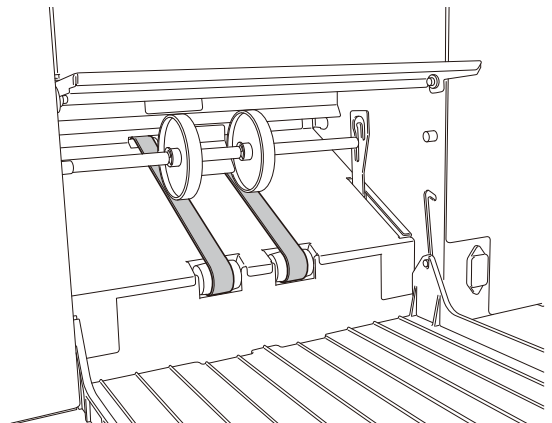

4. Cleaning sensors

Adhesion of dust to a sensor may cause a false detection. Clean the sensors using an air duster.



- Use a non-flammable air duster. Read the cautions for use well, and be sure to keep the descriptions in mind.
- The sensors and metallic section are cooled by gas in the air duster, and may be temporarily condensed. Wait for about five minutes.

Paper sensor

- 1 Insert the nozzle of air duster into the hole shown in the figure to blow air.

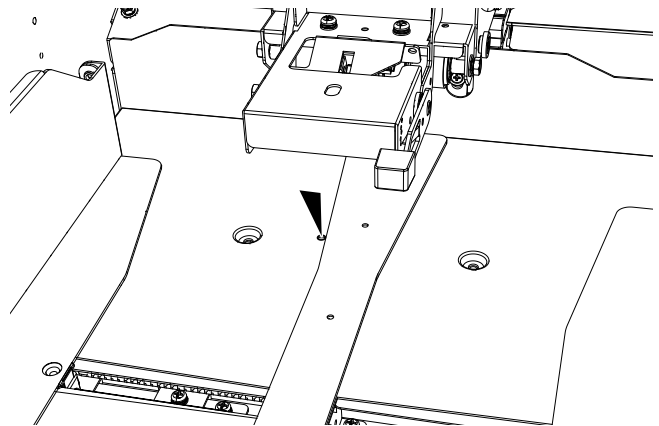

Paper exit sensor upper, home sensor of folding plate 1

- 1 Remove the folding plate 1.



Attach the folding plate 1 holding with both hands.

- 2 Open the top cover.

CAUTION



Open or close the top cover gently.

Hands or fingers may be caught in the cover section. Doing so may result in injury.

3 Insert the nozzle of air duster into the hole shown in the figure to blow air.

- [a] Paper exit sensor upper
- [b] Home sensor of folding plate 1

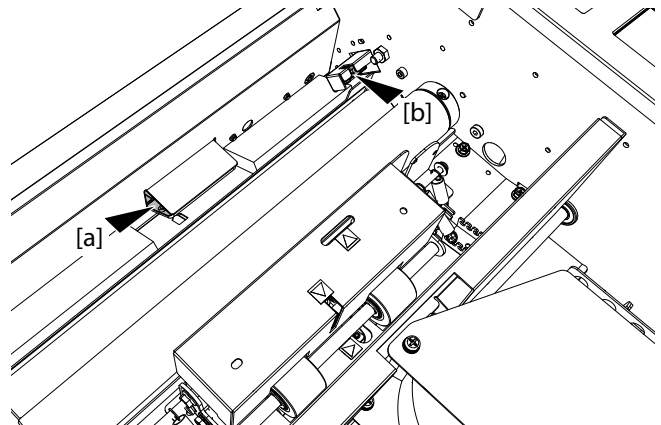

Paper exit sensor lower, home sensor of folding plate 2

1 Remove the folding plate 2.

! Remove the folding plate 2 holding the place shown in the figure with both hands.

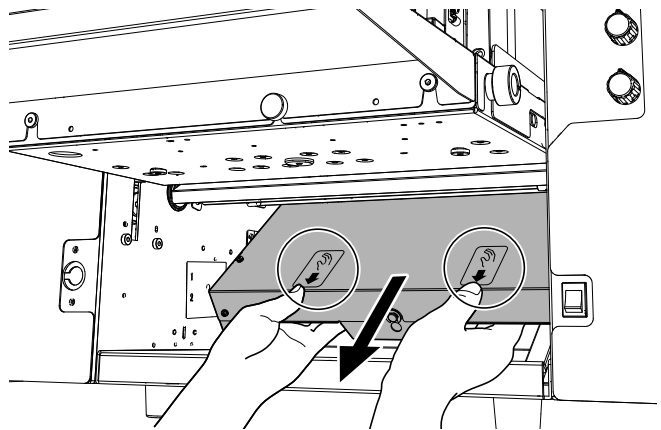

2 Blow air to the folding plate 2 home sensor with an air duster.

- [a] Home sensor of folding plate 2

3 Wipe the paper exit sensor lower with a cloth moistened with water.

- [b] Paper exit sensor lower

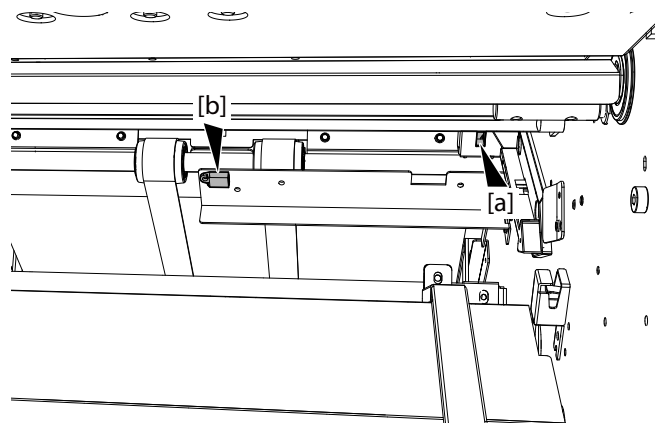

Optical ultrasonic detection sensor, optical double-feed detection sensor, and paper feed timing sensor

- 1 Clean the sensors using an air duster.**
 - [a] Ultrasonic double-feed detection sensor
 - [b] Optical double-feed detection sensor
 - [c] Paper feed timing sensor

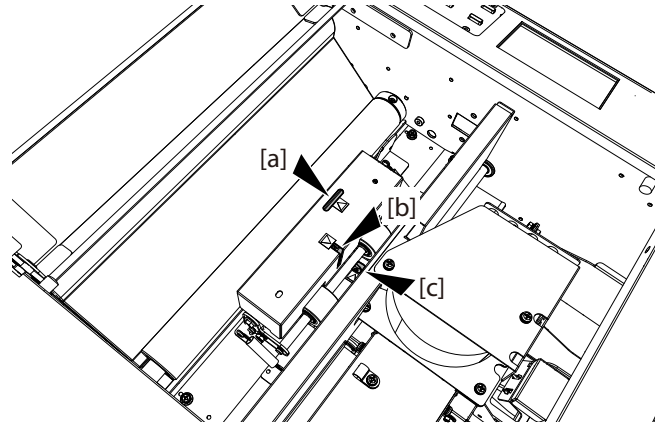

Chapter 5 Trouble Guide

1. Error Code

Check the error code or error message and solve the problem by following the guide displayed on the screen or by referring to list below. If the error cannot be solved by the following methods, contact your dealer.

Depending on the content of the error, the **C** key might not be displayed.

If the **C** key is displayed, check the guide content and touch the **C** key to clear the error.

If the **C** key is not displayed, follow the guide to clear the error.

1-1. Warning error

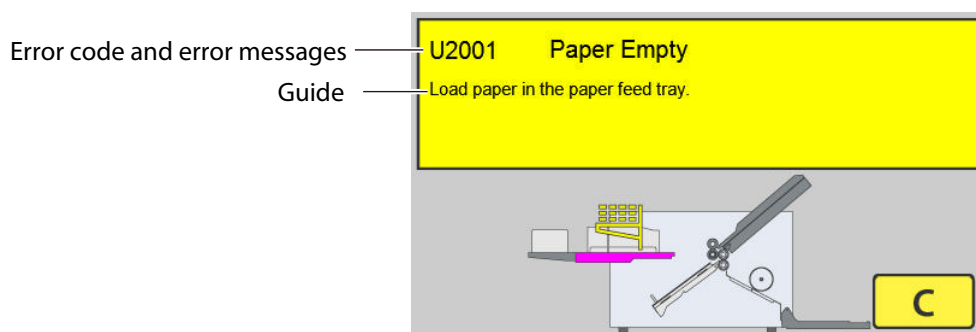

Error Code	Cause	Solution
U1000	The top cover is open.	Close the top cover.
U1500	The folding plate 1 is not attached.	Attach the folding plate 1 correctly.
U1501	The folding plate 2 is not attached.	Attach the folding plate 2 correctly.
U1550	A foreign object was detected under the paper feed tray.	Check if there is a foreign object under the paper feed tray.
U1602	The  key is pressed in a state where test paper feeding is not performed when the optical sensor is set for double-feed detection.	Perform a test feed or change the setting of double-feed detection.
U2005	The direction of paper stacked on the paper feed tray is incorrect.	Load paper in the correct direction. Check if the paper size setting is correct. Touch the C key to clear the error.
U2006	Paper is not detected when the paper feed tray is going up.	Align the paper.
	Back and forth of paper stacked on the paper feed tray is not in alignment.	Align the paper.
	The volume of the paper separating air is small for the paper size.	Increase the setting value by five at a time.
U3006	The setting for the small size paper is not correct.	Touch the C key to clear the error, then make settings for the small size paper.

1-2. Motor error

Follow the guide content to solve the error.

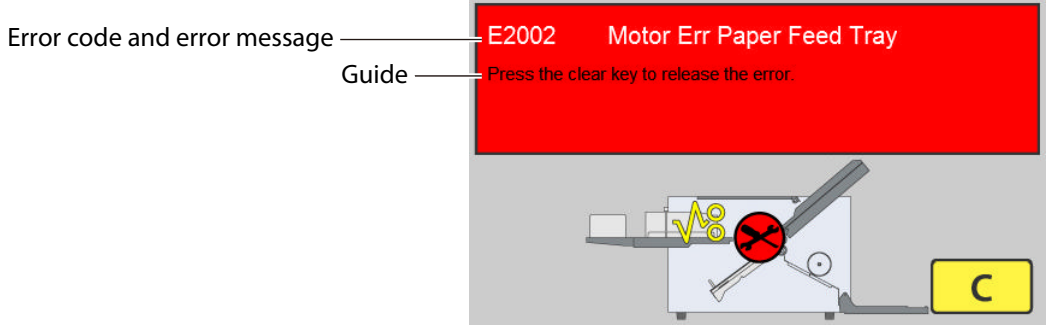

Error Code	Cause	Solution
E2002	Paper jam caused the motor, which automatically elevates the paper feed tray, to be loaded.	Remove jammed paper and touch the C key to clear the error.
E2003		
E2005		
E2220	Paper jam caused excessive load on the motor.	
E2221		
E2410	The folding plate 1 is not attached properly.	Make sure that folding plate 1 is attached properly. Remove jammed paper and touch the C key to clear the error.
E2411		
E2412	Motor for moving the folding stopper is not functioning due to paper jamming, etc.	
E2419		
E2420	The folding plate 2 is not attached properly.	Make sure that folding plate 2 is attached properly. Remove jammed paper and touch the C key to clear the error.
E2421		
E2422	Motor for moving the folding stopper is not functioning due to paper jamming, etc.	
E2429		

1-3. Paper jam error

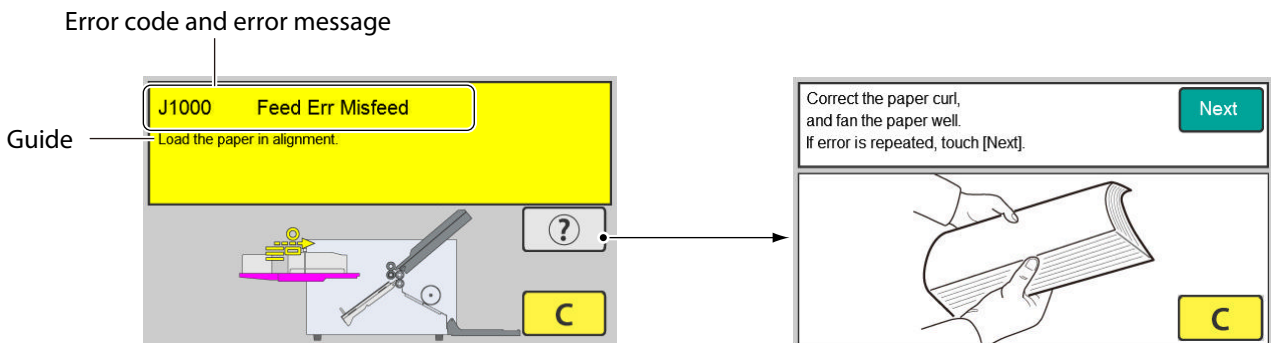

If the same error occurs frequently even when the error is solved by following the guide content, touching the **?** key displays an illustration and guide on how to solve the error.

Error Code	Cause	Solution
J1000	Miss-feed on the paper feed tray.	Align the paper.

Error Code	Cause	Solution
J1001 J1005	Double-feed occurs at the paper feed section.	Remove the double-fed paper.
J1006	Paper jam has occurred in the paper feed section.	Remove the jammed paper.
J3002	Paper jam has occurred inside the machine.	Remove the jammed paper. Clear the error by force ejecting paper or opening and closing the top cover.
J6002	Paper jam has occurred in the paper ejecting section.	Remove the jammed paper.

1-4. Other errors

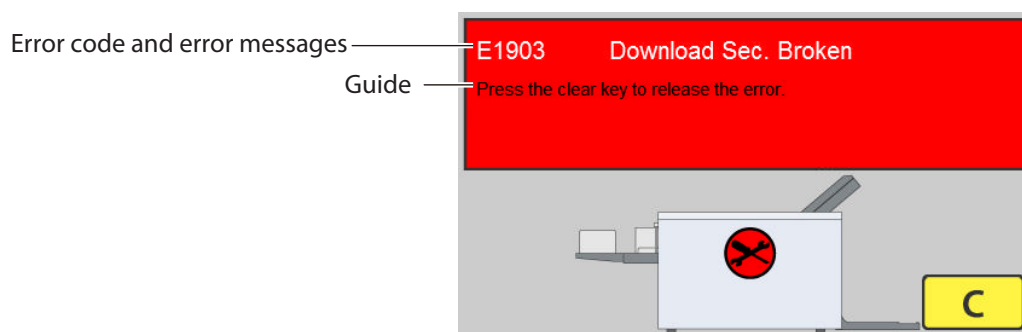



Error Code	Cause	Solution
E1101	A problem has occurred inside the machine.	Turn off and on the machine.
E1902	There is a problem with the program.	Turn off and on the machine.
E1903	There is a problem with the program.	Touch the C key to clear the error.

1-5. Errors requiring service call

When the following error codes are displayed, turn off and on the power. If the error is not solved by turning off and on the power, contact your dealer.

E1101
E1902
E1904
E4200
E4210
E4300
E4301
E4302
E5011
E5012
E5013
E5015
E5770

2. Paper Jam

⚠ CAUTION	
	Do not put fingers inside during operation.
	Keep away long hair, ties, jewelry and loose clothing.
	It could cause injury.

When paper jams, remove the paper in the following way.

2-1. Paper feed section

- 1 Pull out jammed paper slowly.**

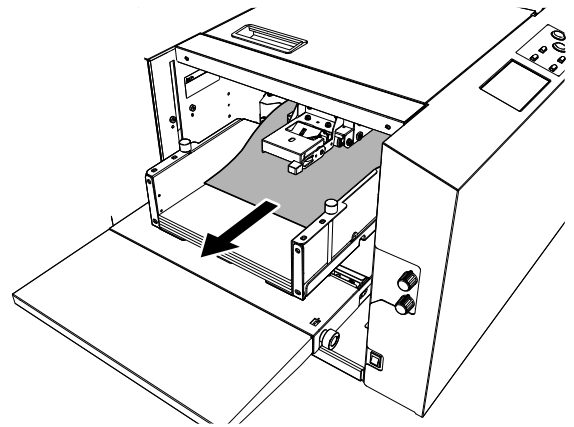

 If paper cannot be pulled out easily, first remove all the paper on the paper feed tray and pull out the jammed paper.

2-2. Folding plate

- 1 Press the  key on the control panel.**
Eject forcibly the paper inside the folding plate.
Hold down the key until the paper is ejected.

Even if the paper is not removed after forcible ejection, check the position of paper jam to remove the paper with the following method.

Folding plate 1

1 Take out the folding plate 1.

! Attach the folding plate 1 holding with both hands.

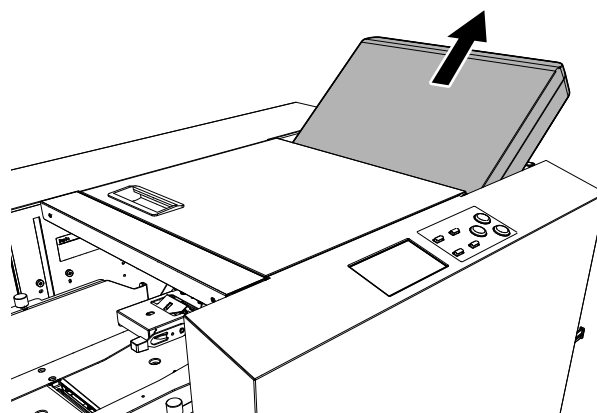

2 Open the top cover.

! WARNING



Open or close the top cover gently.

Hands or fingers may be caught in the cover section. Doing so may result in injury.

3 Pull out the paper rotating the jam correction knob.

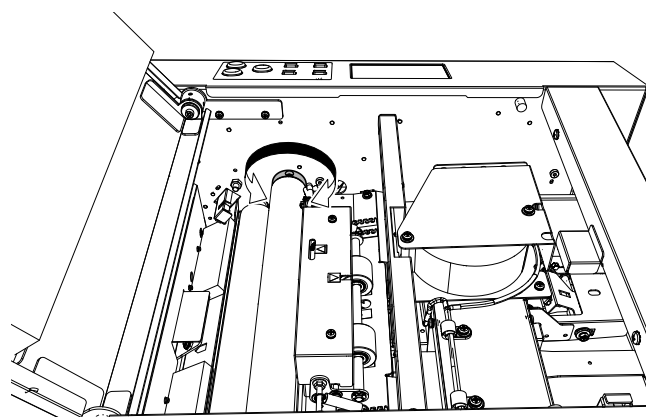

4 Close the top cover.

5 Attach the folding plate 1 along the set guides.

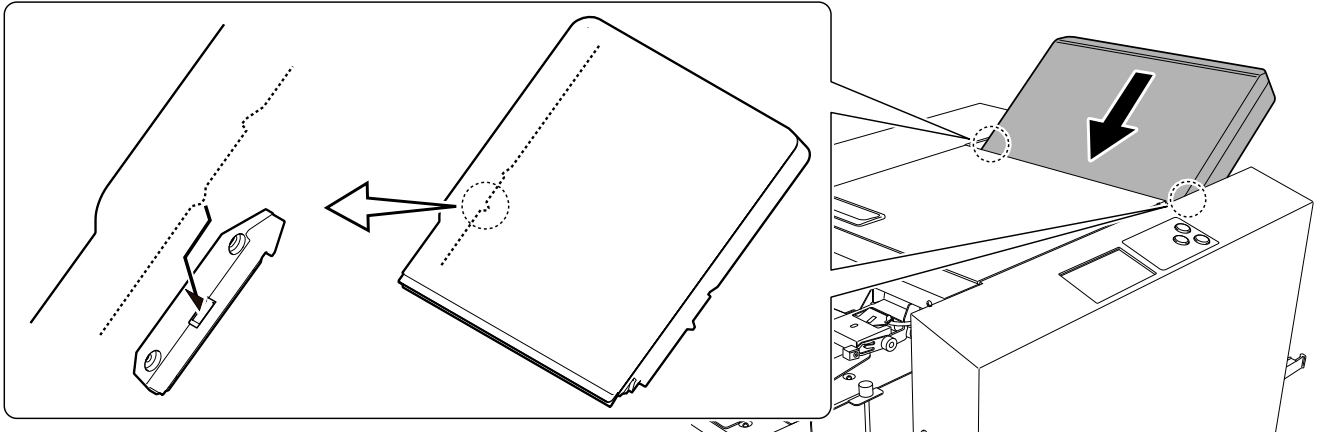

▼ Attach the folding plate 1 holding with both hands.



Check that the gear on the reverse side of the folding plate 1 rotates in the front-back direction, if it is not easy to attach the folding plate 1.

Attach the folding plate 1 to this machine after rotating the gear by 360 degrees in a rotating direction, when it does not rotate either in the front direction or in the back direction.

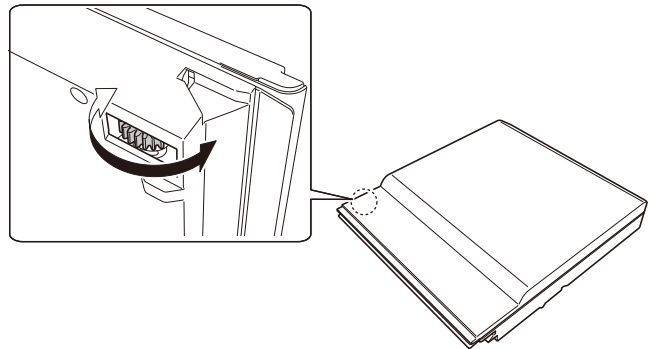

Folding plate 2

1 Take out the folding plate 2.

▼ Attach the folding plate 2 holding the parts shown in the figure with both hands.

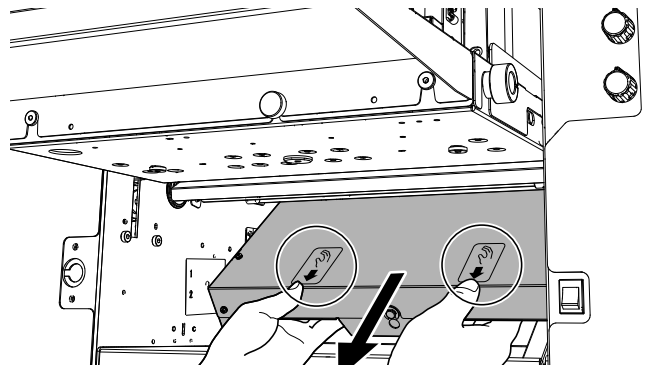

2 Open the top cover.

! WARNING



Open or close the top cover gently.

Hands or fingers may be caught in the cover section. Doing so may result in injury.

3 Pull out the paper rotating the jam correction knob.

4 Close the top cover.

5 Check if the stopper of the folding plate 2 does not protrude beyond the cover.

The folding plate cannot be inserted properly as it bumps into internal parts if the stopper protrudes beyond the cover. If this is the case, turn the gear in the direction of an arrow to move the stopper inside the cover.

- Do not hold the belt section of the folding plate 2. Doing so will result in malfunction of the machine.

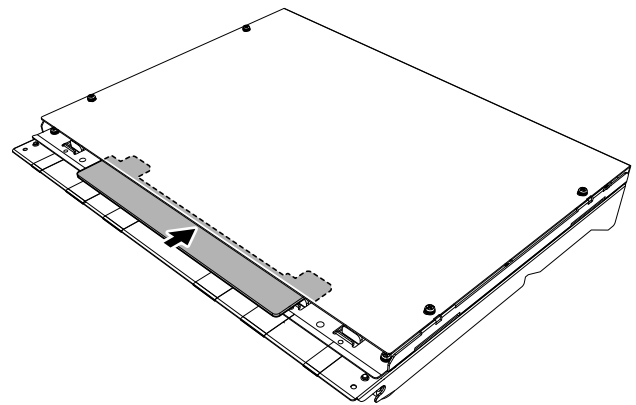
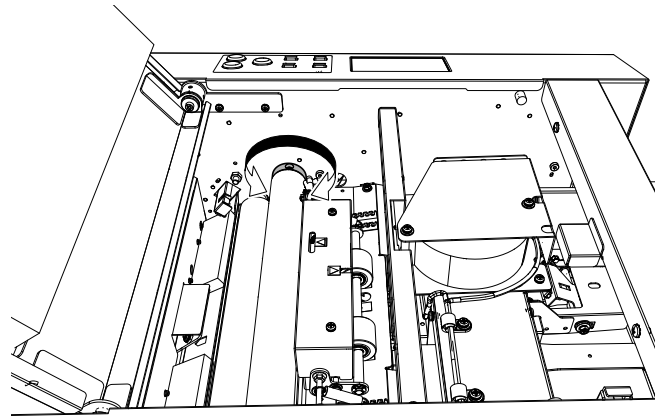

6 Insert the folding plate 2 into the main body of the machine.

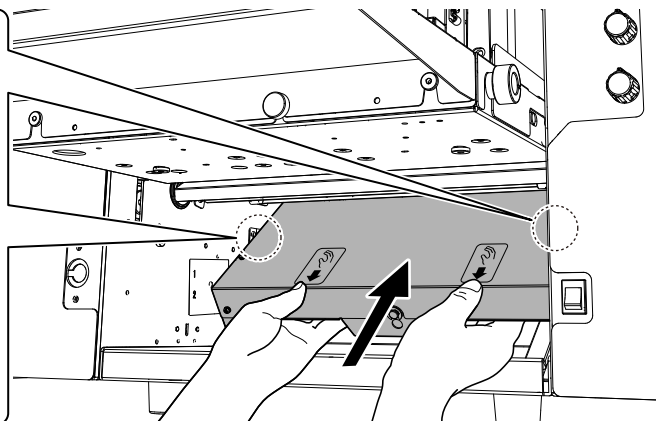
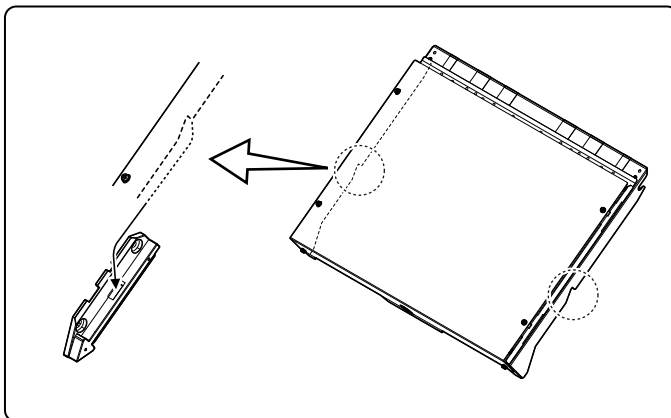

- 1) Insert the folding plate 2 in the direction of 1 in the right figure along with the set guide of the main body of the machine.

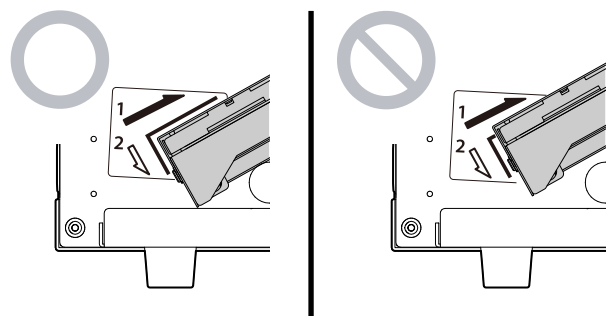

- 2) Check that the folding plate 2 will be inserted in the direction of 2 in the figure.
Be sure to check that the folding plate 2 is attached properly as shown in the figure.

! Attach the folding plate 2 holding with both hands.

2-3. Folding roller

- 1 Take out the folding plate 1.

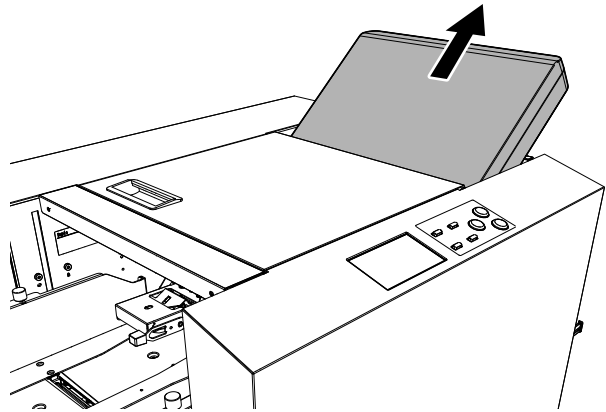

- 2 Take out the folding plate 2.

! Attach the folding plate 2 holding the parts shown in the figure with both hands.

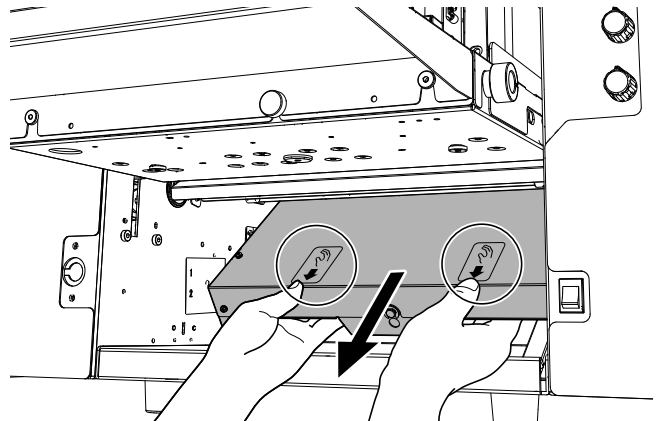

- 3 Open the top cover.

! WARNING

! Open or close the top cover gently.
Hands or fingers may be caught in the cover section. Doing so may result in injury.

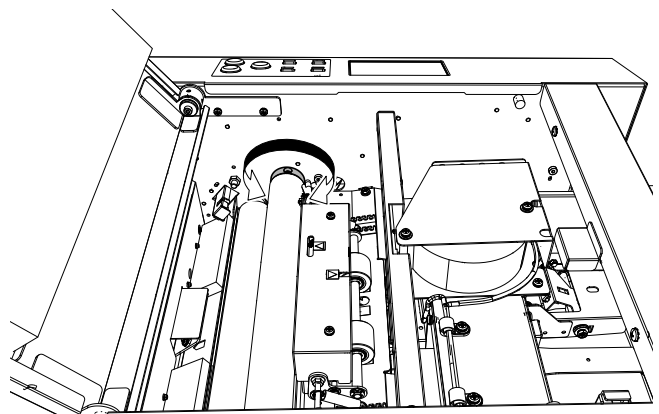

- 4 Pull out the paper rotating the jam correction knob.

- 5 Close the top cover.**
- 6 Insert the folding plate 1 and folding plate 2.**

 "2-2. Folding plate" (p.82).

2-4. Ejecting section

- 1 Press the  key on the control panel.**
The paper is forcibly ejected.
Paper is ejected forcibly as long as the key is held down. Forcible ejection will stop by releasing the key.

3. Troubleshooting

WARNING



Do not use a flammable static electricity removal spray.

Doing so could cause build-up of gas inside the machine, which in turn could cause ignition, resulting in fire and explosion.

Condition	Cause	Solution
Power can not be turned on.	The power cord is not connected.	Connect the power cord.
The machine does not start operation when the  key is pressed.	Paper is not stacked.	Stack paper on the paper feed tray. (p.30)
	The paper switch is not responding.	Stack paper in correct position so that the paper switch responds.
	Paper has jammed.	Remove jammed paper. (p.82)
	The top cover is open.	Close the top cover.
	Non-standard paper is used in standard paper settings.	Change the settings to match non-standard paper. (p.46)
	The paper feed guide is off the paper size detection area.	Secure the paper feed guide correctly.
	Test folding is not performed even though the setting is changed to on in [D-Feed Detect].	Perform test folding. (p.37)
The folding stopper of the folding plates 1 or 2 does not operate.	Other non-standard paper is used.	Input the paper size. (p.46)
	The folding plates 1 and 2 are not set properly.	Set the folding plates 1 and 2 properly. (p.82)
Paper is not folded at the normal folding position.	The folding plates 1 and 2 are not set properly.	Set the folding plates 1 and 2 properly. (p.82)
	Static electricity is built up on paper.	<ul style="list-style-type: none"> Use a commercially available static electricity removal spray. Separate the paper well. (p.27) Humidify with a humidifier as required.

Condition	Cause	Solution
Paper jam occurs.	Paper is not separated well.	Separate the paper well. (p.27)
	Paper is curled.	Correct the paper curl before use. (p.27)
	The folding roller is stained.	Clean with a cloth moistened with alcohol. (p.74)
	The stacker roller is not positioned correctly.	Re-set the position of the stacker roller. (p.55)
	Static electricity is built up on paper.	<ul style="list-style-type: none"> • Use a commercially available static electricity removal spray. • Separate the paper well. (p.27) • Humidify with a humidifier as required.
	The clearance between the separator and suction belt is small.	Turn the separator adjustment knob to large scales. (p.36)
	The trail edge guide unit is pressed against the paper strongly.	Set the trail edge guide unit so that it will be in contact with the paper lightly. (p.31)
	The separating air adjustment knob is not positioned properly.	Turn the separating air adjustment knob to large scales. (p.36)
	Separating air volume is too low	Turn up [Separating Air] volume by [5] scales at a time. (p.36)
	Thick paper is used.	Set the stack height sensor to the first scale from the bottom. (p.36)
Paper feed interval is not stable.	Paper is curled.	Correct the paper curl before use. (p.27)
	Thick paper is used.	Set the stack height sensor to first scale from the bottom. (p.36)
The leading edge of paper does not misalign too much, but double-feed occurs.	Paper is sticking and difficult to separate.	Check that the printing ink of the paper has dried and there is no static electricity, and then separate the paper well. (p.27)
	Paper out of specifications is used.	Do not use paper outside the specifications. (p.26)
	Paper is not stacked in alignment.	Stack the paper in alignment. (p.27)
	Loaded paper is more than 50 mm/ 1.96 inches in height.	Load paper so that it is less than 50 mm/1.96 inches in height. (p.30)
	The separating air adjustment knob is not positioned correctly.	Turn the separating air adjustment knob to small scales. (p.36)
	Separating air volume is too large.	Turn down [Separating Air] volume by [5] scales at a time. (p.35)
	Pickup air volume is too large.	Turn down [Pickup Air] volume by [5] scales at a time. (p.35)
	The clearance between the separator and suction belt is too large.	Turn the separator adjustment knob to small scales. (p.36)
	The stack height sensor is not positioned correctly.	Set the stack height sensor to the standard position. (p.36)
Paper is put on the paper detection sensor.	Stack paper again on the paper feed tray. (p.30)	

Condition	Cause	Solution
Double-feed occurs with the leading edge of paper misaligned largely.	Paper out of specifications is used.	Do not use paper outside the specifications. (p.26)
	Paper is not stacked in alignment.	Stack the paper in alignment. (p.27)
	Loaded paper is more than 50 mm/ 1.96 inches in height.	Load paper so that it is less than 50 mm/1.96 inches in height. (p.30)
	The side guide unit is pressed against the paper strongly.	Set the side guide unit leaving some clearance between the side guide unit and paper. (p.32)
	The separating air adjustment knob is not positioned correctly.	Turn the separating air adjustment knob to large scales. (p.36)
	Separating air volume is too low	Turn up [Separating Air] volume by [5] scales at a time. (p.36)
	Pickup air volume is too large.	Turn down [Pickup Air] volume by [5] scales at a time. (p.35)
	The clearance between the separator and suction belt is too large.	Turn the separator adjustment knob to small scales. (p.36)
	The stack height sensor is not positioned correctly.	Set the stack height sensor to the standard position. (p.36)
Miss-feed occurs.	The suction belt is stained.	Clean the belt with a cloth moistened with alcohol. (p.75)
	Paper is sticking and difficult to separate.	Check that the printing ink of the paper has dried and there is no static electricity, and then separate the paper well. (p.27)
	Paper out of specifications is used.	Do not use paper outside the specifications. (p.26)
	Paper is not stacked in alignment.	Stack the paper in alignment. (p.27)
	The paper feed guide is pressed against the paper strongly.	Set the paper feed guide so that it touches the paper lightly. (p.31)
	Suction timing is delayed because paper is too large and heavy.	Set [Feed Interval] to [Slow]. (p.63)
	The separating air adjustment knob is not positioned correctly.	Turn the separating air adjustment knob to small scales. (p.36)
	Separating air volume is too large.	Turn down [Separating Air] volume by [5] scales at a time. (p.35)
	Pickup air volume is too low.	Turn up [Pickup Air] volume by [5] scales at a time. (p.35)
	The clearance between the separator and suction belt is small.	Turn the separator adjustment knob to larger scales. (p.35)
	The stack height sensor is not positioned correctly.	Set the stack height sensor to the standard position. (p.36)
	The side guide unit is pressed against the paper strongly.	Set the side guide unit leaving some clearance between the side guide unit and paper. (p.32)
	When using thin paper or curled paper, or using small size paper with [Feed Interval] set to [Fast], mis-feed may occur for the second sheet or later.	Set [Pickup Air] to 20 to 30. (p.35)
Paper does not reach the folding roller.	When using thick paper or slippery paper, the spring pressure of the conveyance roller is low. Adjust the spring pressure of the conveyance roller to increase spring pressure. (p.58)	

Condition	Cause	Solution
Folding misalignment along the vertical length of the paper occurs.	Processing speed was changed midway through operation.	Adjust the folding stopper positions of the folding plates 1 and 2. (p.44)
	Paper type (quality, thickness) was changed midway through operation.	
	The folding plate was removed when [Stopper Fixed] was set to on.	
Folding misalignment along the sides of the paper occurs.	Too many sheets of paper are stacked.	Reduce the paper amount.
	The paper feed guides are not set properly.	Set the paper feed guides properly. (p.31)
	The fixing screws of the paper feed guides got loose and the paper feed guide slipped out of position.	Tighten the fixing screws of the paper feed guides. (p.30)
	Paper is not cut properly.	Correct the folding misalignment along the sides of the paper using the skew correction knob. (p.42)
Continuous-feeding occurs with small paper.	Paper out of specifications is used.	Do not use paper outside the specifications. (p.26)
	The paper feed guides are not set properly.	Set the paper feed guides properly. (p.31)
	Paper is not properly aligned.	Stack the paper in alignment. (p.27)
	Thin flimsy paper is used.	Lower the processing speed. (p.37)
	Paper size with limitations in processing speed is used.	
	Paper feed interval timing is too fast.	Set [Feed Interval] to [Slow]. (p.63)
The pickup air volume is too large.	Set the [Pickup Air] volume according to the paper type. (p.35)	
Single-folded thick paper jams at the folding rollers.	Paper out of specifications is used.	Do not use paper outside the specifications. (p.26)
	The processing speed is too slow.	Increase the processing speed. (p.37)
	Paper is not separated well.	Separate the paper well. (p.27)
When large paper is stacked on the paper feed tray, the tray does not rise even when the  key is pressed.	Too many sheets of paper are stacked.	Reduce the paper amount.
	Heavy paper is used.	
Mis-detection of double-feed occurs.	Test folding is not carried out after the paper is re-stacked.	Perform test folding whenever new sheets of paper are re-stacked. (p.37) Repeat test folding when a miss-feed or double-feed error occurs.
	Paper thickness in the double-feed detection setting is not appropriately set.	Check the paper thickness, change the setting of paper thickness to [Thick] and test fold again. (p.61)
	The printing state is variable within the range of double-feed detection.	Set the ultrasonic sensor in the [D-Feed] setting to off. (p.61)
Mis-detection of mis-feed occurs.	Paper is fed askew.	Align paper appropriately and stack the paper at a proper position. (p.27)
	Although double-feed detection is set to on, the paper thickness is not appropriate.	Check the paper thickness, and set [Thickness] to [Thin] and test fold again. (p.61)

Condition	Cause	Solution
Paper jam occurs in cross fold.	The trail edge guide unit is pressed against the paper strongly.	Set the trail edge guide unit leaving some clearance between the trail edge guide unit and paper. (p.52)
	The set values of separating air and pickup air are not proper.	Set the values of each air applicable to cross fold. (p.51)
	The clearance between the separator and suction belt is small.	Turn the separator adjustment knob to large scales. (p.36)
	The stack height sensor is not positioned correctly.	Set the stack height sensor to the standard position. (p.36)
	The processing speed is too fast.	Set the processing speed to [4] or less. (p.37)
	Paper feed interval timing is too fast.	Change [Feed Interval] to [Normal]. When handling thick paper, change the setting to [Slow]. (p.63)
Paper creases in cross fold.	Separating air volume is too large.	Turn down [Separating Air] volume by [5] scales at a time. (p.36)
Thin or flimsy paper gets wrinkled lengthways.	The spring pressure of the conveyance roller is high.	Adjust the spring pressure of the conveyance roller to decrease spring pressure. (p.58)

Chapter 6 Appendix

1. Specifications

Design and specifications are subject to change without notice.

Basic specifications

Model		FD 3300	
Item	Unit		
Paper feed tray paper loading capacity	mm	50 (*1)	
	inch	1.96 (*1)	
Power supply	Voltage	V	
	Frequency	Hz	
Current consumption	A	1.9 to 0.8	
Power consumption	W	190	
Airborne noise	Conditions	With the machine placed on the table with the height of 0.6 m/23.62 inches, measured at a distance of 1 m/39.37 inches from the control panel and at a height of 1.55 m/61.03 inches from the floor. Noise test EN13023 J.3.1.1 – Grade 3 – Paper quality: Fine quality paper 81.4 g/m ² /21.6 lb (Vertical) – Paper size: A4 – Processing speed: 7 – Folding mode: Single fold	
	Equivalent continuous A-weighted sound pressure level (L _{Aeq}) (*2)	dB	76
	Sound pressure level at peak (L ^{Pc})		96
Dimensions (W x D x H)	When used	mm	1,193 x 587 x 541
		inch	47.0 x 23.2 x 21.3
	When stored	mm	806 x 587 x 541
		inch	31.8 x 23.2 x 21.3
Mass	kg	67.5 (*2)	
	lb.	148 (*2)	

(*1) Fine quality paper 81.4 g/m²/21.6 lb (equivalent to 490 sheets)
25 mm/0.98 inch or less for cross fold

(*2) Including accessories

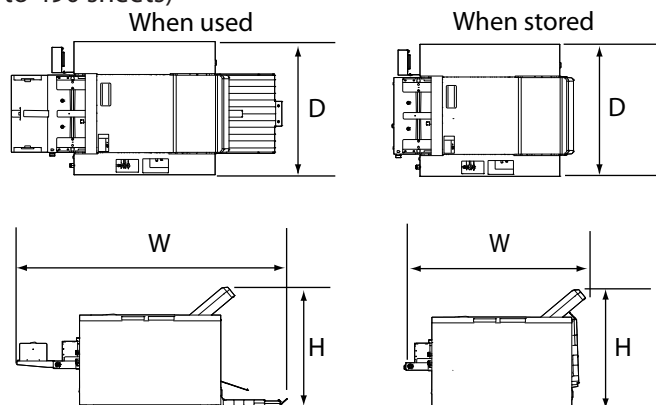

Media

Model			FD 3300
Item		Unit	
Paper size (W x L)	Maximum	mm	311.0 x 457.2
		inch	12.24 x 18.00
	Minimum	mm	120.0 x 182.0
		inch	4.73 x 7.17
	Standard paper	EU	A3/ B4/ A4/ B5/ A5/ B6
NA		LGR (double letter)/LGL (legal)/ LTR (letter)/ STMT (statement)/INV (invoice)	
Paper type			Sheet Single fold
Paper quality (thickness)	Fine quality paper	g/m ²	52.3 to 157.0 (*1)
		lb	35.56 to 106.76 (*1)
	Art paper/ coated paper	g/m ²	73.3 to 157.0 (*2)
		lb	49.84 to 106.76 (*2)

(*1) Depending on the paper manufacturing conditions, rough paper, stencil paper, recycled paper and medium quality paper are outside the specifications. A folding test is necessary.

Processing speed must be 3 or less for fine quality paper 81.4 g/m²/22 lbs.

In high humidity environment (exceeding 65%)

- Processing speed must be 5 or less for A4 to A5 fine quality paper 157 g/m²/106.76 lbs.
- Folding quality with fine quality paper 157 g/m²/106.76 lbs that is smaller than A5 is out of specifications.

In low temperature (20°C/68°F or less)

- Folding quality with fine quality paper 157 g/m²/106.76 lbs that is other than A4 to B5 is out of specifications.

(*2) Depending on the paper manufacturing conditions, it will be out of the specifications. A folding test is necessary.

For A4, letter, short grain, single fold, 230 g/m² or less can be used.

Processing speed must be 3 or less for coated paper that is less than 104.7 g/m²/71.20 lbs.

In high humidity environment (exceeding 65%)

- Processing speed must be 5 or less for coated paper 104.7 g/m²/71.20 lbs or more.

Performance and functions

Model			FD 3300
Item		Unit	
Processing speed	Maximum	Sheets/ min.	310 (*1)
Folding form (*2)			Single fold/ Double fold/ Irregular accordion fold/ Letter fold/ Accordion fold/ Gate fold (*3)/ Specified cross fold (*4)/ Other deformed folding (*5)
Folding speed adjustment (*6)	6 speed	Sheets/ min.	260
	7 speed		310

- (*1) Paper quality: Fine quality paper 81.4 g/m²/21.6 lbs (long grain)
Paper size: A4 (lengthways)
Folding mode: Single fold
- (*2) The type of folding modes available may be limited depending on the paper quality and size.
Only single fold is applicable to thick paper 157 g/m²/106.76 lbs or heavier and larger than B4.
Double fold or irregular accordion fold-out of B6 paper is only applicable for 64 g/m²/16 lbs paper.
However, only under the condition that processing speed is set to 4 or faster, and folding dimension B is 47.0 mm /1.85 inches or more.
Only single fold is applicable to 157 g/m²/106.76 lbs paper under low temperature conditions (20°C/68°F or below).
- (*3) Short grain paper of 64 g/m²/16 lbs or less cannot be used. The paper length also has to be 432 mm/17.00 inches or less.
- (*4) Fine quality paper 52.3 to 104.7 g/m²/ 14.0 to 41.0 lbs
(127.9 g/m²/34 lbs paper can be used only for single fold)
Coated paper: 73.3 to 157 g/m²/ 19 to 40 lbs)
(157 g/m²/106.76 lbs paper can be used only for single fold)
Paper size (after single fold): width 128.0 to 210.0 mm/5.04 to 8.27 inches
: length 182.0 to 297.0 mm/7.17 to 11.69 inches
- (*5) The maximum folded length of paper folded has to be 230.0 mm/9.05 inches or less.
- (*6) Paper quality: Fine quality paper 81.4 g/m²/ 21.6 lbs (Vertical)
Paper size: A4
Folding mode: Single fold
Feed interval: Fast
Standard setting range: 1 to 7 speed
Thin paper mode: 1- speed