

FORMAX[®]

FD 322
Document Folder

TABLE OF CONTENTS

TOPIC	PAGE
DESCRIPTION, SPECIFICATIONS	1
UNPACKING, SETUP	2
OPERATION	3
UPPER & LOWER FOLD PLATES	4
DAILY MAINTENANCE	5
TROUBLESHOOTING	6 - 7

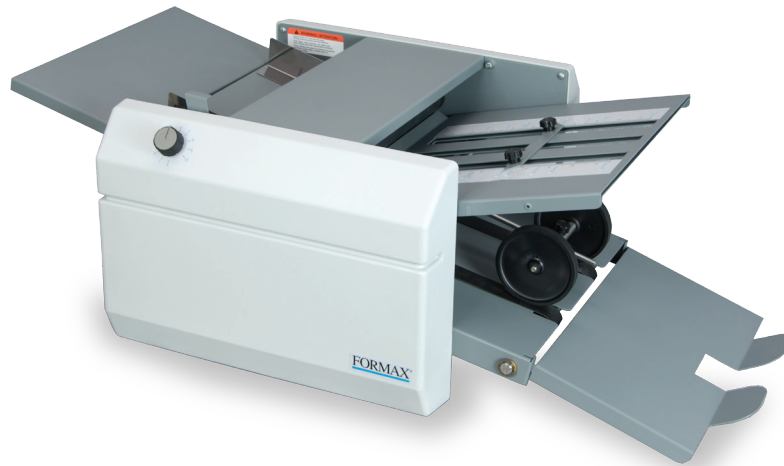

The FD 322 Folder is pre-marked for three standard folds - C, Z and Half - and can be easily adjusted to create custom folds - Gate, Fold Out, Double Parallel. It can accommodate paper sizes up to 11", 14", and 17" in length.

SPECIFICATIONS

SPEED:	Up to 11,000 sheets per hour
MAXIMUM PAPER SIZE:	11.75" x 18" (298 x 457 mm)
MINIMUM PAPER SIZE:	3.125" x 4" (79.4 x 101.6 mm)
FOLD TYPES:	C, Z, Half, and Custom Folds (Gate, Fold Out, Double Parallel)
HOPPER CAPACITY:	Up to 250 sheets 20#
WEIGHT:	55 lbs. (25 kg)
POWER:	FD Model: 120V, 60Hz, 3Amps FE Model: 220V, 50Hz, 2Amps

UNPACKING

Check package for shipping damage. If there is shipping damage, do not discard the box.

CAUTION: Two people must lift machine out of the box.

1. Lift up the infeed tray extension (see below) and insert the outfeed ramp into place.
2. Remove packing material from lower fold plate and ensure proper installation.
3. Plug cord into wall outlet.
4. Turn machine on by pressing the power switch to the on position speed control knob to the right.

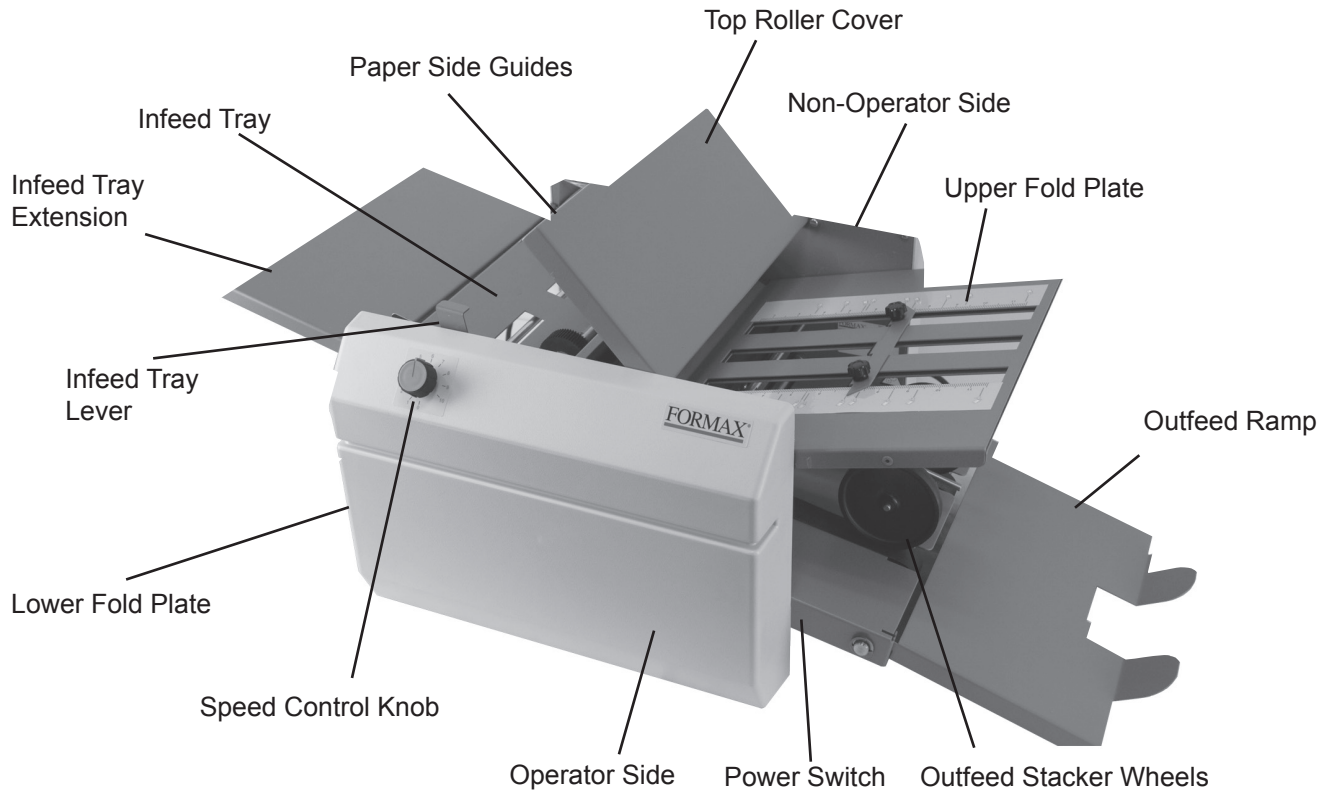

SETUP & DESCRIPTION

Paper Side Guides:

Adjust the side guides so the center of the sheet is aligned with the feed roller and paper can slide freely between the guides without excessive play. To adjust, grip the guides and slide into position. NOTE: Improper setting of the paper guides may cause inconsistent folding or skewed folds.

Speed Control Knob:

The speed control is variable to control sheets per hour. Generally, faster speeds are better suited for heavier stock and slower speeds for lighter stock. NOTE: Always make final fold adjustments at the speed you intend to fold.

Outfeed Stacker Wheels:

The stacker wheels are located on the outfeed ramp, and are designed to arrange the folded sheets into an overlapping stack. Position the stacking wheel assembly so the leading edge of the folded sheet touches the wheels when the trailing edge just falls onto the conveyor table.

Top Cover:

The top cover encloses the infeed tires to reduce noise, increase safety and prevent dust from entering. Be sure to close the cover prior to operation. A safety sensor will not allow the folder to operate if the cover is open.

OPERATION

Adjusting the fold plates:

To adjust fold plates to desired fold and length of paper, first loosen the two thumbscrews on each of the two fold plates. Second, align the fold stop so the marks on each side of the fold plates match.

Letter, accordion and half folds are clearly marked on each fold plate with blue lines. Adjustments can be made by loosening the thumbscrew and slightly moving the center bar up or down. Tighten the thumbscrews before operation.

For a "half" fold you must remove the lower fold plate and rotate it 180 degrees and reinsert the fold plate.

NOTE: Remember to tighten the thumbscrews and replace the fold plates before operating.

Upper Fold Plate

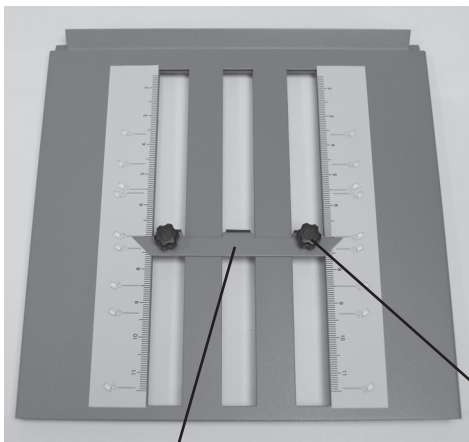

Fold stop

Lower Fold Plate

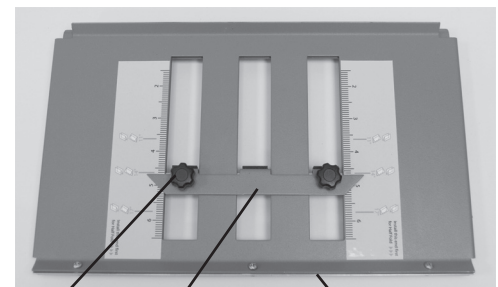

Fold stop

Half fold diverter

Thumbscrews

Power Switch

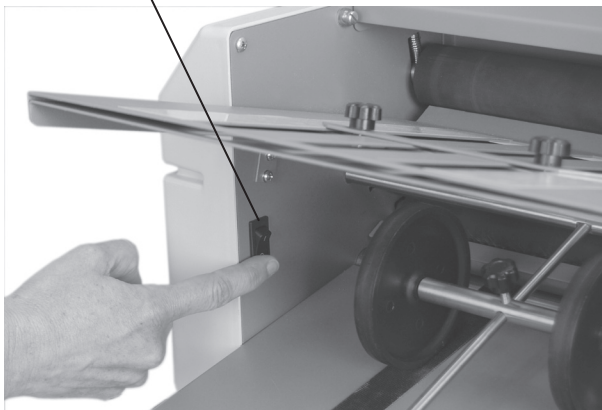

Speed Control



UPPER & LOWER FOLD PLATE REMOVAL & INSTALLATION

Removing the upper fold plate:

Using both hands, firmly lift the end of plate and pull the fold plate up slightly and back. (Fig. 1)

Installing upper fold plate:

Slide the fold plate on the top of the upper guide pins and ensure that the lower guide pins are in the slots of the front of the fold plate pushing in, then down until plate locks into place. (Fig. 2)



Fig. 1

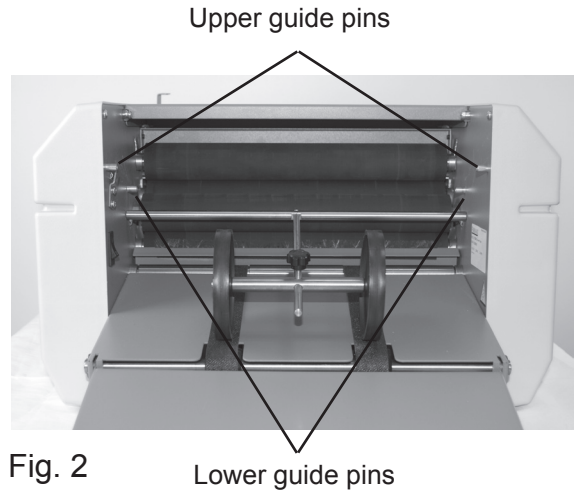

Fig. 2

Removing the lower fold plate:

Holding the end of the lower fold plate, lift then pull back (Fig. 3).

Installing the lower fold plate:

Slide fold plate up between the upper support rod and the bottom of the paper ramp insure that fold plate locks into place on the lower guide pins (Fig. 4).

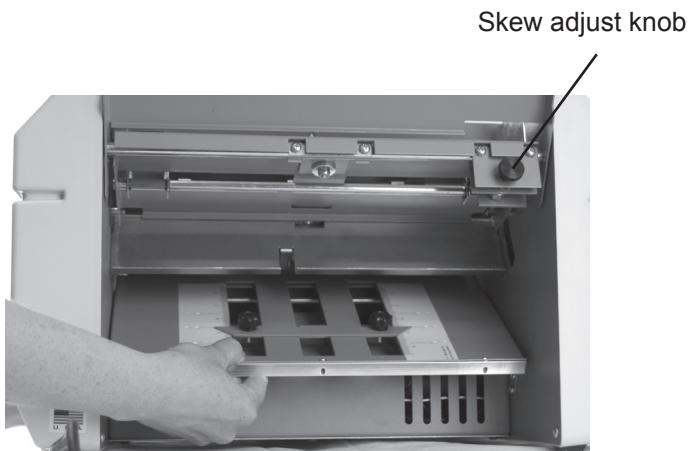

Fig. 3

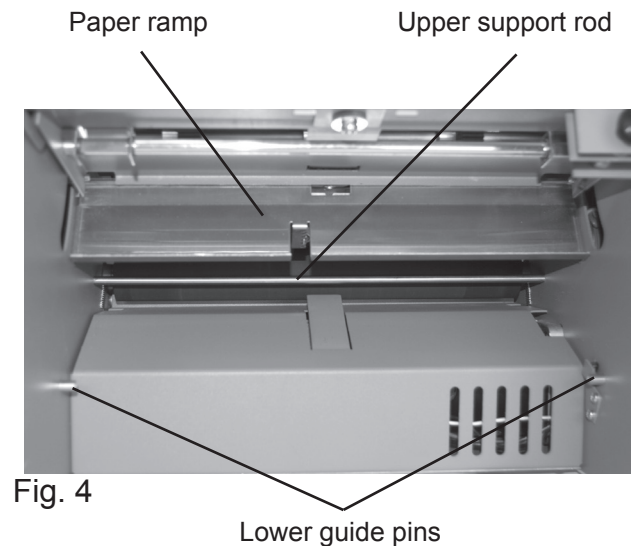

Fig. 4

DAILY MAINTENANCE

Feed roller:

After a period of normal operation ink, toner, lint and other contaminants will coat the feed roller. Clean the feed roller by wiping with a damp cloth coated with a mild soap and water solution.

CAUTION: Do not use rubber roller cleaner or other solvents on the feed roller. To maximize the gripping power of the feed roller and to remove any remaining contaminants, go over the feed roller surface with a 3M-Scotchbright pad or equivalent. Replace the feed roller when excessive wear is apparent or when a single sheet will no longer feed successfully.

Fold rollers:

During normal operation, the fold rollers will become coated with ink, toner, lint and various other contaminants. Contaminated folding rollers can cause a variety of folding problems. Clean the folding rollers on a periodic basis, according to the procedure below. Regular cleaning will ensure optimum performance and add years of life to the folding rollers.

1. Disconnect the power cord.
2. Remove the lower fold chute.
3. Open the top roller cover.
4. Liberally spray solution across the rollers (soap and water solution or roller cleaner).
5. Using a clean cloth, briskly clean each roller until no more contaminants appear on the cloth surface. Rotate the rollers and continue to clean until all roller surfaces are clean.

TROUBLESHOOTING

PROBLEM:	POSSIBLE CAUSE:	SOLUTION:
Folder will not start	Machine not plugged into an active wall outlet	Plug machine into an active outlet
	Power switch not turned on	Turn power to the on position
	Speed control knob not turned up	Increase speed by turning knob to the right
	Top cover not closed	Close top cover
	Fold plate(s) not inserted	Insert fold plate(s)
	Feed table not fully elevated	Check feed table is not being blocked from going up and reset if necessary
	Fuse blown	Replace blown fuse, located under the outfeed stacker
	Electrical malfunction	Have folder checked by qualified technician
Paper will not feed	Paper guides too tight	Adjust the paper guides so a single sheet of paper slides freely between the guides without excessive play
	Worn feed roller	Replace feed roller - Contact qualified technician
	Loose motor belt	Adjust or replace motor belt - Contact qualified technician
Improper stacking	Stacking wheels improperly set	Realign the stacker wheels
Skewed folds	Excessive side play between paper guides and paper edges	Adjust paper guides and skew adjust
	Paper not square	Readjust the paper in the infeed tray
	Infeed table not square	Adjust table by turning the skew adjust knob back and fourth until skew is eliminated
	Fold table paper stops improperly set or not locked into position	Adjust paper stops and lock into position
	Contaminated fold rollers	Clean fold rollers with a damp cloth coated with a mild soap and water solution

PROBLEM:	POSSIBLE CAUSE:	SOLUTION:
Ink smudges on paper	Ink not dry	Allow additional ink drying time before folding. Some inks do not dry, they only set (dry to the touch). Because of the physical nature of friction feeding, you may notice a mark on the leading edge of the paper.
	Excessive toner on photocopied stock	Check photocopier
	Dirty fold rollers	Clean rollers
Paper jams	More than a single sheet fed into folder	Adjust the singulator according to instructions in the feed adjustment section. Replace feed roller or singulator if necessary. Contact qualified technician
	Folded sheets backing into the folder	Reset the stacking wheels according to instructions in stacker wheel setup (page 2).
	Obstruction in fold plate	Check paper path for pieces of paper and remove the jammed paper.
Wrinkled paper	Feed table paper guides too tight	Set guides so a single sheet slides freely down between the guides without excessive side play.
	Dirty fold rollers	Clean fold rollers.
	Fold roller springs worn	Replace with new springs. Contact qualified technician
	Worn fold rollers	Fold rollers should be replaced when gaps appear between the rollers. Contact qualified technician
Folds more than a single sheet	Worn feed roller	Check to see if feed tire is worn. Replace if necessary.
	Singulator needs adjustment	Adjust the singulator so a only a single sheet will be fed.
	Dirty/worn feed wheel	Clean or replace feed wheel.