

FORMAX[®]

FD 260 Tabber

TABLE OF CONTENTS

1. INTRODUCTION	1
1.1 Organization of this Operating Manual	1
1.2 FD 260 Description	1
1.3 Items Included	3
1.4 Operating Manual Safety Terms	4
1.5 Safety Precautions.....	5
1.6 Operating Manual Terms	5
1.7 Warranty	6
1.8 Ordering Additional Equipment.....	6
2. SPECIFICATIONS & REQUIREMENTS	7
2.1 Specifications.....	7
2.2 Operating Requirements.....	7
3. POWER CONNECTION	8
3.1 Safety.....	8
3.2 Line Voltage.....	8
3.3 Line Fuses	10
3.4 Accessory Fuses.....	11
3.5 Accessory Power Outlet.....	12
3.6 Power Cord.....	12
4. CONTROLS.....	13
4.1 Power Switch	13
4.2 LCD Counter	13
4.3 Gap Adjustment Lever	14
4.4 Tab Size Switch.....	14
4.5 Control Panel	14
4.5.1 Tab Ready.....	14
4.5.2 Clear Tab	15
4.5.3 On/Off	15
5. FEEDING DEVICES	16
5.1 Placing the FD 260 In-Line	16
5.2 FD 260-10 Feeder	17
6. OPERATION.....	19
6.1 Threading Tabs.....	19
6.2 Feeding Mail Pieces.....	22
6.3 Tabbng Mail Pieces	22
6.4 Removing Waste Backing Paper	24

7. MAINTENANCE.....	25
7.1 General Cleaning & Clearing	25
7.1.1 Removing Tabs & Debris From Peel Point Area	25
7.2 Replacing A Fuse	26
7.2.1 Line Fuse.....	26
7.2.2 Accessory Fuse	27
8. TROUBLESHOOTING	29
8.1 Troubleshooting Chart	29
9. CORRECTING TABBING PROBLEMS	32
9.1 No Tabs Applied To Mail Pieces.....	23
9.1.1 Sensor Could Not Detect Tab	32
9.1.2 Sensor Is Not Tuned For Clear Tabs	33
9.1.3 Mail Piece Jam	34
9.1.4 Torn Backing Paper.....	36
9.1.5 Incorrect Threading	37
9.2 Poor Tab Placement or Appearance.....	38
9.2.1 Tab Placement Is Inconsistent.....	38
9.2.2 Tab Fold Is Uneven	38
9.2.3 Tab Fold Is Off Mail Piece -- Tab Is Tenting	40
9.2.4 More Than One Clear Tab On Mail Piece.....	41
10. SERVICE	42
10.1 Service	42
10.2 Repacking Instructions.....	42

1. INTRODUCTION

1.1 Organization Of This Operating Manual

This manual starts with a description of your FD 260, then describes its set up, operation and maintenance. Finally, information is offered to help you determine what can go wrong and what to do about it. There are many helpful tips along the way, and it is strongly suggested that you become familiar with this entire manual prior to operating the FD 260.

1.2 FD 260 Description

The FD 260 is an automatic tabbing machine used to seal open mail pieces. Tabs are peeled from rolls of backing paper and applied to mail pieces such as self-mailers, brochures, newsletters and double postcards.

Mail pieces are fed into the FD 260 using a feeding device such as the FORMAX FD 260-10 Feeder, or a feeder or labeler from another manufacturer. If the FD 260 is to work correctly, mail pieces must be fed into it correctly -- with a gap of about one inch between mail pieces. This manual does not cover the operation of the various feeding devices that may be used to supply the FD 260 with mail pieces. Please read your feeding device operating manual before using it in-line with the FD 260.

NOTE

Some feeding devices require a stand in order to operate in-line with the FD 260. Check with your FORMAX dealer.

The FD 260 uses a tabbing head to advance rolls of pressure-sensitive tabs past a peel bar. Partially peeled tabs hang from the backing paper, ready to be peeled at the peel bar before they contact the mail piece. Tabs are pressed onto mail pieces between a sweep and rolls. The tabbed mail pieces exit the FD 260 and can be collected in an optional FORMAX

FD 260-20 Conveyor.

Tab quality is as important as mail piece quality. Poor quality tabs and mail pieces take longer to run, jam often and produce poor results. Only genuine FORMAX brand tabs are 100% guaranteed to run on FORMAX Tabbers, and are the only tabs that say FORMAX on the box. Imitation tabs can be run on FORMAX Tabbers, but are not guaranteed to run problem-free.

The FD 260 depends on a smooth flow of both tabs and mail pieces. This flow is monitored by a set of sensors and a microprocessor. As with most microprocessor-controlled machines, the FD 260 needs a few seconds to get itself ready to run. When you turn the power on, the FD 260 takes 5 seconds to boot up. During this time, all lights flash and the control panel is inoperative.

Signals from sensors are fed to the microprocessor which monitors the condition of the tabbing head and lets you know the condition through lights on the control panel. Without correct sensing, the FD 260 will behave improperly. The FD 260's sensors work like all other electric eyes. When an object breaks the beam of light (the SENSOR BEAM) between them, an electrical signal is generated. It is imperative that this SENSOR BEAM PATH be maintained in its proper condition and alignment at all times. The emitter half of the sensor is located under the transport tray beneath the peel bar. It can be seen by looking into the FD 260, along the paper path below the peel bar. The detector half is shrouded under the steel covers at the input end of the FD 260 in front of the peel bar.

Debris and stray tabs can become caught in the paper path and sensor beam. Rough, careless handling of the FD 260 can cause the sensors to become mis-aligned. Both of these conditions must be prevented. The FD 260 requires periodic cleaning and reasonable handling. Paper dust build-up or abuse will bring the successful operation of the FD 260 to an end. Take care of your FD 260 by following the set up, operation and maintenance instructions in this manual.

1.3 Items Included

The following items are shipped together in one box.
Take note of each as you unpack the box.

- FD 260 Tabber
- Power cord
- Operating Manual
- 1 roll of white tabs
- 1 roll of clear tabs

WARNING
THE FD 260 IS A HEAVY MACHINE.
USE PROPER LIFTING TECHNIQUES TO
SET IT ON A WORK SURFACE.

1.4 Operating Manual Safety Terms

The following highlighted blocks are used throughout this manual to emphasize important information. **Pay careful attention to this information.**

WARNING
ALERTS YOU TO ACTIONS OR CONDITIONS
THAT MAY PRESENT HAZARDS OR CAUSE
INJURY TO PERSONNEL.

CAUTION
ALERTS YOU TO ACTIONS THAT MAY CAUSE
LOSS OF MATERIALS (MAIL PIECES AND TABS)
OR DAMAGE TO EQUIPMENT.

NOTE
Draws your attention to an important
statement or action.

TIP
A suggestion to enhance the FD 260's
productivity.

1.5 Safety Precautions

Observe the following safety precautions and warnings when operating, cleaning or repairing the FD 260. Failure to do so may result in physical injury or damage to the FD 260. The manufacturer assumes no liability for your failure to comply with these requirements.

WARNING
NEVER CLEAN, CLEAR OR DISASSEMBLE THE FD 260 WITHOUT FIRST UNPLUGGING THE POWER CORD.

WARNING
KEEP LOOSE CLOTHING, TIES, SCARVES AND HAIR AWAY FROM ALL MOVING PARTS.

WARNING
DO NOT PLACE FINGERS OR TOOLS BETWEEN OR NEAR MOVING PARTS.

1.6 Operating Manual Terms

The following terms are used throughout this manual:

input end where mail pieces enter

output end where mail pieces exit

operator side side where the controls are located

non-operator side opposite the operator side

1.7 Warranty

NOTE

Your FORMAX FD 260 is covered under warranty by the dealership from which you purchased it.

Formax warrants your FD 260 against defects in materials and workmanship for a period of six months from the original ship date when used in accordance with the operating instructions in this manual. This warranty covers the cost of parts when the machine is presented by its original purchaser to an authorized FORMAX Service Center. Should warranty repairs become necessary, the service provider, at his/her option, will repair or replace such parts required to restore the FD 260 to serviceable condition.

This warranty does not cover consumable parts such as belts, rollers and sweeps used to contact and transport mail pieces and tabs. This warranty does not extend to incidental or consequential damages arising out of a warranty claim, or to costs associated with maintenance of the equipment. This warranty does not cover damages resulting from shipping, accident, misuse, abuse, neglect, mishandling, alteration or modification. Your rights under this warranty may vary from state to state.

1.8 Ordering Additional Equipment

To order, or find out about, additional Formax equipment or supplies, contact an authorized Formax dealer.

2. SPECIFICATIONS & REQUIREMENTS

2.1 Specifications

Size & Weight

10" L x 17" H x 21" W -- 47 lb. assembled

Power

Possible line voltages are 240V, 230V, 220V, 120V, and 100V at 50-60 Hz

2.2 Operating Requirements

Mail Piece Size

Height: 3¹/₂" minimum, 9" maximum

Width: 5" minimum, 12" maximum

Mail Piece Thickness

Minimum: single sheet of 20 lb. bond paper tri-folded

Maximum: 1/4"

Tab Specs

Tab width: between 1" and 1.5"

Tab length: 1", 1.5"

Backing paper width: between 1.125" (1" tab) and 1³/₄" (1.5" TABS)

Maximum roll diameter: 8.25"

Core Diameter: 3"

Tab Position Accuracy

±¹/₁₆" guaranteed when using Formax Tabs within their specified shelf life

Mail Piece Fold Quality

Folds in mail pieces must result in perfectly flush panels. A lip (one panel longer than another on the same mail piece) will result in torn mail pieces when tabbed.

Production

Over 15,000 mail pieces (4¹/₈" long) per hour

3. POWER CONNECTION

WARNING
BEFORE PLUGGING THE FD 260 INTO AN OUTLET, CAREFULLY READ THE FOLLOWING INFORMATION ABOUT VOLTAGES, FUSES AND THE POWER CORD.

3.1 Safety

The FD 260 can connect to any power distribution system, including the European IT Power System. Because the European IT Power System does not have a grounded neutral leg, the FD 260 uses protective fusing in both the neutral and hot supply lines of power.

WARNING
A BLOWN FUSE IN THE NEUTRAL LEG COULD MEAN INTERIOR PARTS OF THE FD 260 REMAIN AT A HAZARDOUS VOLTAGE. ALWAYS UNPLUG THE POWER CORD BEFORE REMOVING COVERS FROM THE FD 260.

3.2 Line Voltage

The FD 260 is rated for continuous operation using a variety of supply voltages. Possible line voltages are 240V, 230V, 220V, 120V and 100V at 50 or 60 Hz. The manufacturer configures the FD 260 to operate with the voltage requested by the customer.

CAUTION
VERIFY THE CORRECT VOLTAGE SETTING BEFORE PLUGGING THE FD 260 INTO AN OUTLET.

Read the current voltage setting through the **VOLTAGE SELECTOR WINDOW** on the non-operator side of the FD 260. (Refer to **Figure 3.1.**) Use the following instructions to change the voltage setting:

NOTE

The detachable POWER CORD may have to be changed to match the particular power-source output.

1. Unplug the POWER CORD.
2. Use a small screwdriver or similar tool to push up on and release the FUSE DRAWER LOCKING TAB.
3. Pull the FUSE DRAWER out of the POWER ENTRY CASING.
4. Pull the VOLTAGE SELECTOR out of the FUSE DRAWER.
5. Rotate the VOLTAGE SELECTOR until the correct voltage is on the same side as the VOLTAGE SELECTOR WINDOW.
6. Place the VOLTAGE SELECTOR in the FUSE DRAWER and verify the correct voltage selection.
7. Place the FUSE DRAWER in the POWER ENTRY CASING.

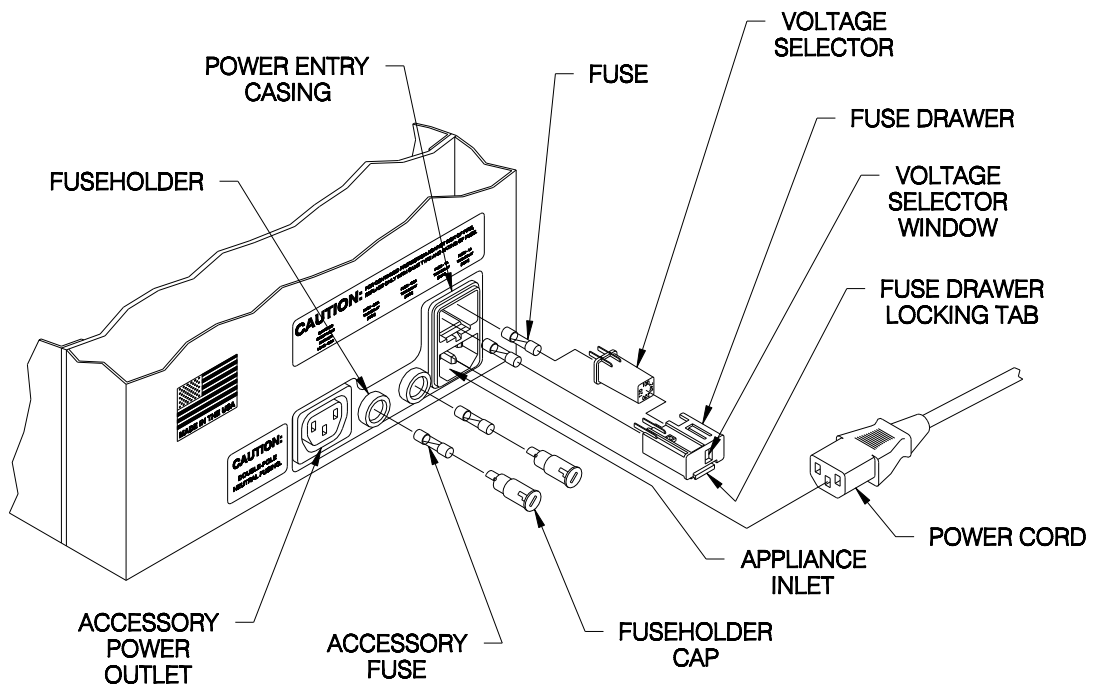

Figure 3.1 - FD 260 Power Connection

3.3 Line Fuses

The FUSE DRAWER located on the non-operator side contains two LINE FUSES. (Refer to **Figure 3.1.**) The neutral and hot lines of power are fused. Both LINE FUSES must be intact for the FD 260 to operate properly.

CAUTION
VERIFY THAT THE LINE FUSE VALUE IS
CORRECT FOR THE VOLTAGE SETTING.
UNPLUG THE FD 260 BEFORE STARTING THIS
PROCEDURE.

Use the following instructions to verify that the LINE FUSES installed have the proper fuse value or to replace a blown fuse:

1. Unplug the POWER CORD.
2. Use a small screwdriver or similar tool to push up on and release the FUSE DRAWER LOCKING TAB.
3. Pull the FUSE DRAWER out of the POWER ENTRY CASING. The LINE FUSES are inside.
4. Determine the proper fuse value as well as the condition of the LINE FUSE. The fuse value is shown on the metal tip of the LINE FUSE. The chart below lists the selected voltage in the left column followed by the proper fuse value in the right column.

<u>Selected Voltage</u>	<u>Line Fuse Value</u>
100V.....	1.0A (250V time delay)
120V.....	1.0A (250V time delay)
220V.....	0.5A (250V time delay)
240V (or 230V).....	0.5A (250V time delay)

5. Replace the LINE FUSE if necessary. Both LINE FUSES must be intact for the FD 260 to operate properly.
6. Install the FUSE DRAWER in the POWER ENTRY CASING.

3.4 Accessory Fuses

Two FUSEHOLDERS are located on the non-operator side between the APPLIANCE INLET and the ACCESSORY POWER OUTLET. (Refer to **Figure 3.1.**) The FUSEHOLDERS hold two ACCESSORY FUSES which protect the ACCESSORY POWER OUTLET. As with the LINE FUSES mentioned previously, both the neutral and hot lines are fused. Both ACCESSORY FUSES must be intact for the FD 260 to properly supply power to in-line equipment.

WARNING
UNPLUG THE POWER CORD BEFORE STARTING THIS PROCEDURE.

Use the following instructions to verify that the ACCESSORY FUSES installed have the proper fuse value or to replace a blown fuse:

1. Unplug the POWER CORD.
2. Use a small screwdriver or similar tool to press in and rotate the FUSEHOLDER CAP **counterclockwise** to release this cap.
3. Pull the FUSEHOLDER CAP (with the ACCESSORY FUSE inside) out of the FUSEHOLDER.
4. Verify the fuse value. Inspect fuses, replace if blown.

<u>Selected Voltage</u>	<u>Line Fuse Value</u>
100V.....	6.3A (250V time delay)
120V.....	6.3A (250V time delay)
220V.....	3.15A (250V time delay)
240V (or 230V).....	3.15A (250V time delay)

5. Install the ACCESSORY FUSE and the FUSEHOLDER CAP in the FUSEHOLDER. Both ACCESSORY FUSES must be intact for the FD 260 to properly supply power to in-line equipment.
6. Using the screwdriver, press in and turn the FUSEHOLDER CAP **clockwise** to lock it.

3.5 Accessory Power Outlet

The ACCESSORY POWER OUTLET is located next to the FUSEHOLDER on the non-operator side. (Refer to **Figure 3.1.**) This outlet supplies power to equipment running in-line with the FD 260.

Typical in-line equipment includes feeders and labelers. Since the ACCESSORY POWER OUTLET gets its power from the FD 260, you can control power to in-line equipment using the FD 260's POWER SWITCH. Additionally, the FD 260 features an automatic interrupt that disables the ACCESSORY POWER OUTLET in case of a jam. The ACCESSORY POWER OUTLET is limited to a 6.3A maximum for 100V and 120V, and 3.15A maximum for 220V and 240V.

3.6 Power Cord

The FD 260 comes with a three-wire POWER CORD. The POWER CORD grounds the FD 260 when connected to an approved three-contact electrical outlet.

1. Plug the POWER CORD into the APPLIANCE INLET on the non-operator side. (Refer to **Figure 3.1.**)
2. Plug the POWER CORD into a grounded outlet.

WARNING
TO PREVENT ELECTRICAL SHOCK, ONLY PLUG THE POWER CORD INTO A GROUNDED OUTLET.

4. CONTROLS

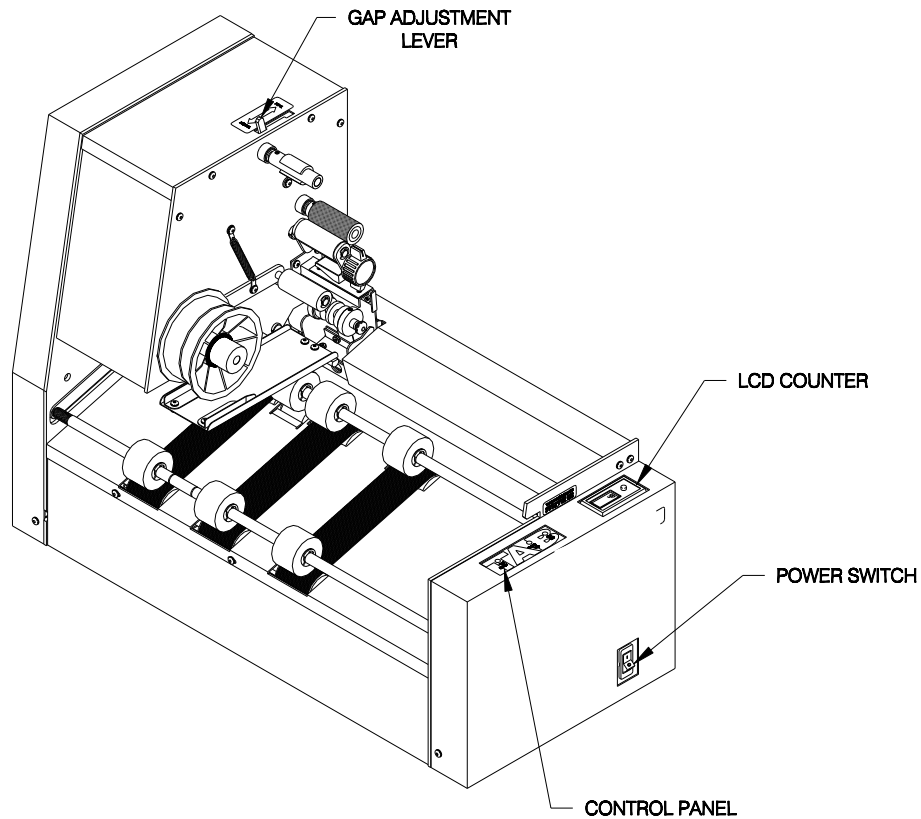

Figure 4.1 - FD 260 Controls

4.1 Power Switch

The POWER SWITCH is located on the bottom of the operator side panel. (Refer to **Figure 4.1**) Turn the POWER SWITCH on to supply power to the FD 260.

4.2 LCD Counter

The LCD COUNTER is located on the top of the operator side panel. (Refer to **Figure 4.1**) The LCD COUNTER displays the current number of tabbed mail pieces fed through the FD 260. Reset the LCD COUNTER by pressing the red button.

4.3 Gap Adjustment Lever

The GAP ADJUSTMENT LEVER on top of the FD 260 tabbing head. (Refer to **Figure 4.1.**) controls the size of the gap between the upper and lower feed rolls.

mail piece thickness:	set lever to:	Upper feed rolls will:
from 1/8" to 1/4"	THICK	raise up
thinner than 1/8"	THIN	Lower down

CAUTION
TO AVOID A JAM, ALWAYS MAKE SURE THE GAP ADJUSTMENT LEVER IS SET CORRECTLY FOR THE MAIL PIECES BEING TABBED.

4.4 Tab Size Switch

Toggle between 1.0 and 1.5 inch tabs with the power OFF. The switch is located to the left of the Control Panel.



Figure 4.2 Tab Size Selector Switch

4.5 Control Panel

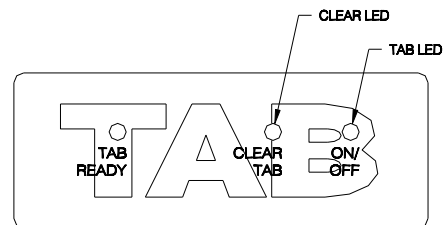

Figure 4.3 - FD 260 Control Panel

4.5.1 Tab Ready

The TAB READY light illuminates when a tab is detected at the peel point. Stray tabs at the peel point will also illuminate the TAB READY light.

The TAB READY light also warns you of malfunctions during tabbing by flashing as the FD 260 shuts down.

4.5.2 Clear Tab

The CLEAR TAB control tells the FD 260 whether to detect clear (and translucent) or opaque tabs.

When CLEAR TAB is toggled on, the light illuminates and the sensor is tuned to detect clear tabs. When CLEAR TAB is toggled off, the light doesn't illuminate and the sensor is tuned for opaque (paper) tabs.

NOTE
Before turning CLEAR TAB on, always remove tabs or debris from the peel point area.

If there are clear tabs or debris in the peel point area when CLEAR TAB is activated, the sensor will not correctly detect clear tabs.

If there are opaque tabs or debris in the peel point area when CLEAR TAB is activated, the CLEAR TAB light flashes and neither CLEAR TAB nor ON/OFF can be activated.

4.5.3 On/Off

The ON/OFF control starts and stops tabbing.

Toggle ON/OFF so the light illuminates to begin tabbing. Toggle ON/OFF so the light doesn't illuminate to stop tabbing.

Once ON/OFF is activated, you cannot change the CLEAR TAB selection. To change the CLEAR TAB selection, Toggle ON/OFF off to stop tabbing, remove tabs and debris from peel point area, turn the POWER SWITCH off and on again and make your new CLEAR TAB selection.

NOTE
Once ON/OFF is activated, the CLEAR TAB selection is locked. Even if you stop tabbing by toggling ON/OFF off, the CLEAR TAB selection cannot be changed.

5. FEEDING DEVICES

5.1 Placing The FD 260 In-Line

To operate the FD 260 in-line with your feeding device, place the output end of the feeding device next to the input end of the FD 260. Leave about an $\frac{1}{8}$ " gap between the machines. Align machines to place tabs where desired on the mail pieces.

The gap between the feeding device and the FD 260 may need adjusting if the mail pieces are curled or rigid. If the mail pieces' leading edge curls up, the gap should be larger than $\frac{1}{8}$ " to allow the curled edge to come down before entering the FD 260. If the leading edge curls down, the gap should be as small as possible, so the mail pieces will not fall between the two machines. A rigid mail piece may require a larger gap if it hits the bracket above the FD 260 PAPER PATH.

NOTE

Turn on the FD 260 before turning on any feeding device. If the FD 260 is not turned on first, it will not accept the fed mail pieces.

NOTE

Some equipment, when run in-line with the FD 260, requires a stand to raise it to the level of the FD 260. When ordering additional equipment, specify which machine you plan to operate in-line with the FD 260.

5.2 FORMAX FD 260-10 Feeder

The Formax FD 260-10 Feeder is an automatic, variable speed Feeder. Load a stack of mail pieces into its feed tray to automatically feed one mail piece after another into the FD 260. **Figure 5.1** illustrates the FD 260-10 in-line with the FD 260.

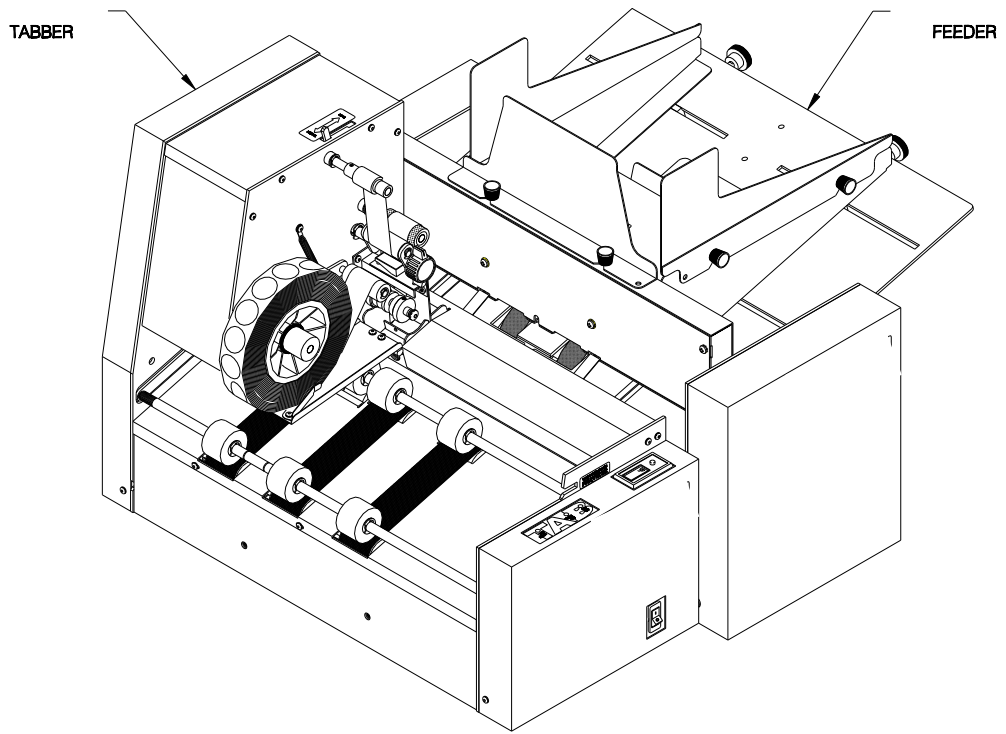

Figure 5.1 - The Formax FD 260-10 Feeder in-line with the FD 260 Tabber.

6. OPERATION

WARNING

KEEP LOOSE CLOTHING, TIES, SCARVES AND HAIR AWAY FROM ALL MOVING PARTS. DO NOT PLACE FINGERS OR TOOLS BETWEEN OR NEAR MOVING PARTS.

6.1 Threading Tabs

To thread tabs:

1. Remove 12 tabs from the leading edge of the tab strip.
2. Remove the outside RUBBER RING, pull down the SHELF and remove both TAB ROLL ADAPTERS from the TAB SPINDLE. (Refer to **Figure 6.1.**)

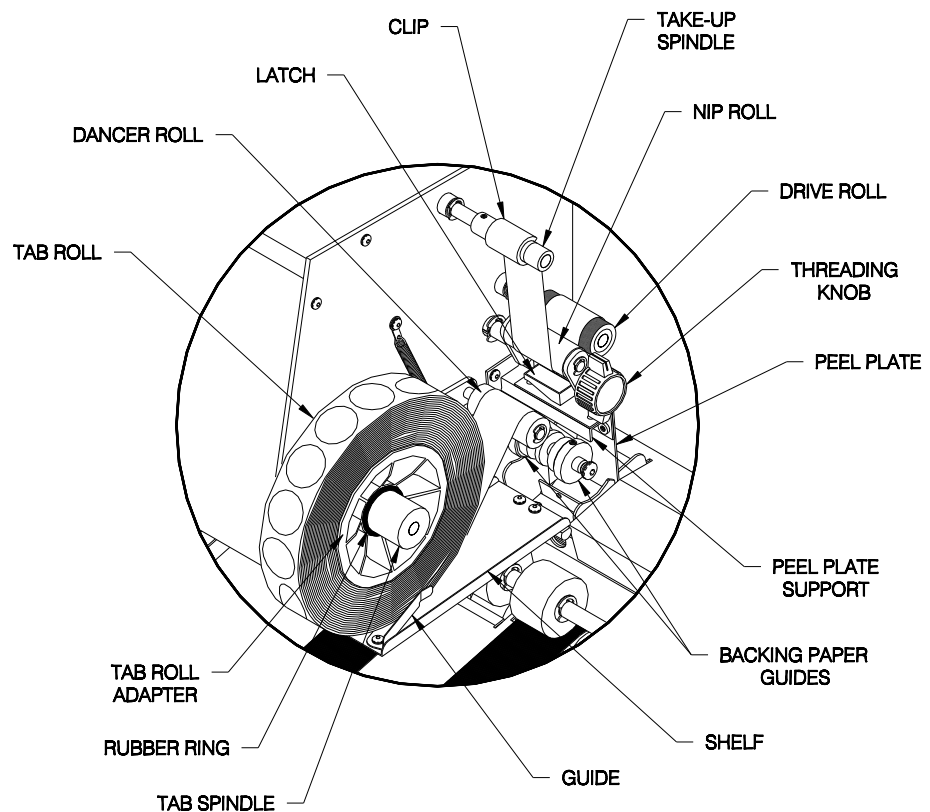

Figure 6.1 – Threading Tabs

3. Insert one or both TAB ROLL ADAPTERS into the core of the TAB ROLL. The TAB ROLL width may allow only one TAB ROLL ADAPTER to fit in the TAB ROLL.
4. Pull the SHELF down. Place the TAB ROLL ADAPTER (rim away from you) with the TAB ROLL attached on the TAB SPINDLE. (Refer to **Figure 6.2.**)

NOTE

The tab strip must pull from the bottom of the TAB ROLL toward the input end -- with the tabs on the bottom of the tab strip -- facing the FEED TRAY.

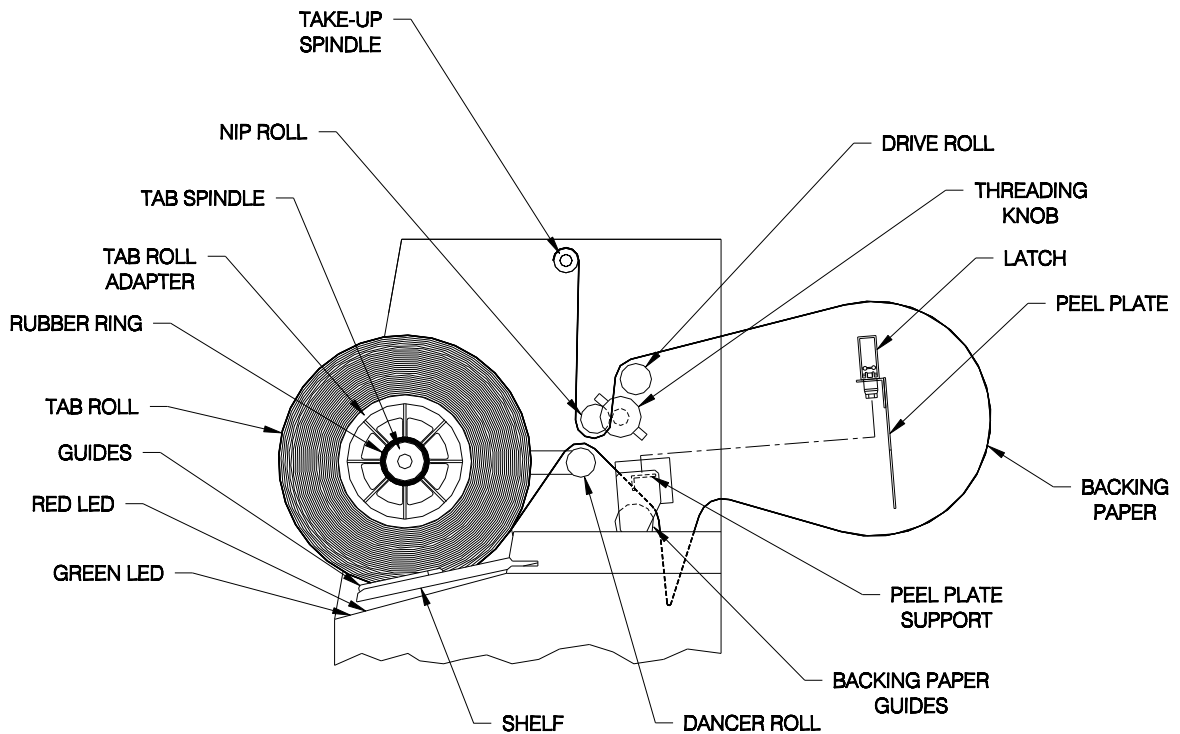

Figure 6.2 - Threading Tabs

5. Center the TAB ROLL between the two GUIDES on the SHELF. Slide these GUIDES against the TAB ROLL. Place the RUBBER RING (removed in step 2) on the TAB SPINDLE. Press both RUBBER RINGS against the TAB SPOOL ADAPTER.
6. Pull up the LATCH on the PEEL PLATE ASSEMBLY and lift the PEEL PLATE ASSEMBLY out of its slot. (Refer to **Figure 6.2.**)
7. Thread the backing paper over the DANCER ROLL. (Refer to **Figure 6.2.**)
8. Thread the backing paper over the BACKING PAPER GUIDES. Slide the BACKING PAPER GUIDES against the backing paper. (Refer to **Figure 6.2.**) There are notches for 1.125" (1" tab) and 1³/₄" (1.5" tab) wide backing paper, but you can use any backing paper between 1" and 1³/₄" wide. The BACKING PAPER GUIDES will stay in place if there are no notches for the backing paper width.
9. Thread 6-8" of backing paper away from the input end and place the PEEL PLATE ASSEMBLY in its slot. Use the PEEL PLATE ASSEMBLY to push the backing paper toward the peel point. Press down and lock the LATCH. (Refer to **Figure 6.2.**) At this point, the backing paper should be over the BACKING PAPER GUIDES, under the PEEL PLATE ASSEMBLY and up towards the TAKE-UP SPINDLE.
10. Thread the backing paper over the DRIVE ROLL. (Refer to **Figure 6.2.**)
11. Turn the THREADING KNOB *counterclockwise* and thread the backing paper between the NIP ROLL and the THREADING KNOB metal bar. (Refer to **Figure 6.2.**) When you release the THREADING KNOB, the gap between the DRIVE ROLL and the NIP ROLL closes.
12. Remove the CLIP from the TAKE-UP SPINDLE, wrap the backing paper around the TAKE-UP SPINDLE and secure the CLIP on the backing paper. (Refer to **Figure 6.1.**)
13. Remove any tabs that have peeled under the PEEL PLATE. Reach them through the INSPECTION WINDOW on the input end.

6.2 Feeding Mail Piece

1. Select Tab Size
2. Turn FD 260's POWER SWITCH on.

NOTE

Turn the FD 260's POWER SWITCH on before turning on the feeding device. If the FD 260 is not turned on first, it will not accept the mail pieces.

3. Toggle ON/OFF so light does not illuminate.
4. Set the FD 260's GAP ADJUSTMENT LEVER to **thick** for mail pieces $\frac{1}{8}$ " to $\frac{1}{4}$ " thick, or to **thin** for mail pieces thinner than $\frac{1}{8}$ ".
4. Place a stack of mail pieces open edge first in the feeding device. Feed several mail pieces. Adjust the feeding speed until the mail pieces feed one at a time with a consistent rhythm.

6.3 Tabbng Mail Pieces

1. Make sure tabs are threaded correctly and peel point area is clear.
2. Turn the POWER SWITCH on.

CAUTION

TO AVOID A JAM, TURN THE FD 260 ON *BEFORE* TURNING ON THE FEEDING DEVICE.

3. Make CLEAR TAB selection. Toggle CLEAR TAB on for clear and translucent tabs. Toggle CLEAR TAB off for opaque tabs.
4. Toggle ON/OFF so the TAB READY light illuminates.

NOTE

Once the ON/OFF light illuminates, you cannot change the CLEAR TAB selection.

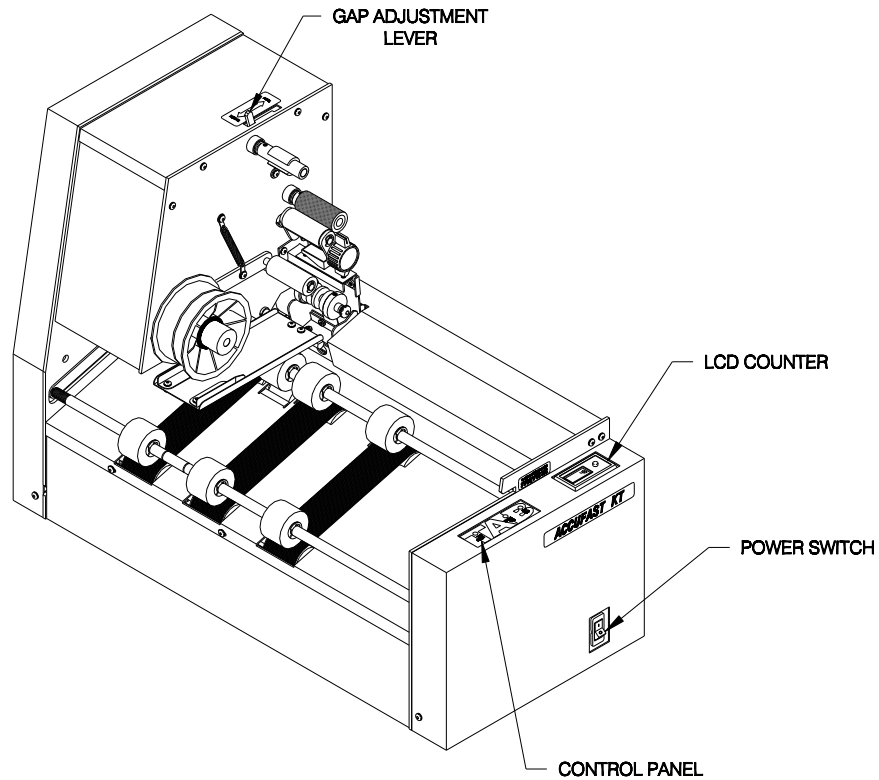

Figure 6.3 – FD 260 Controls

5. Make sure the GAP ADJUSTMENT LEVER is set properly.
6. Begin feeding mail pieces into the FD 260. The TAB READY light will illuminate every time a tab reaches the application point.
7. Make sure each mail piece is tabbed. Re-align the machines if the tabs are not being placed in the desired position on the mail pieces. (Also refer to **Section 5.1.**)

TIP

When finishing a tabbing job, remove the last tab at the peel point to make the next tabbing job start off easier:

1. Toggle ON/OFF so light is off.
2. Feed one mail piece through the FD 260

to

remove the last tab at the peel point.

6.4 Removing Waste Backing Paper

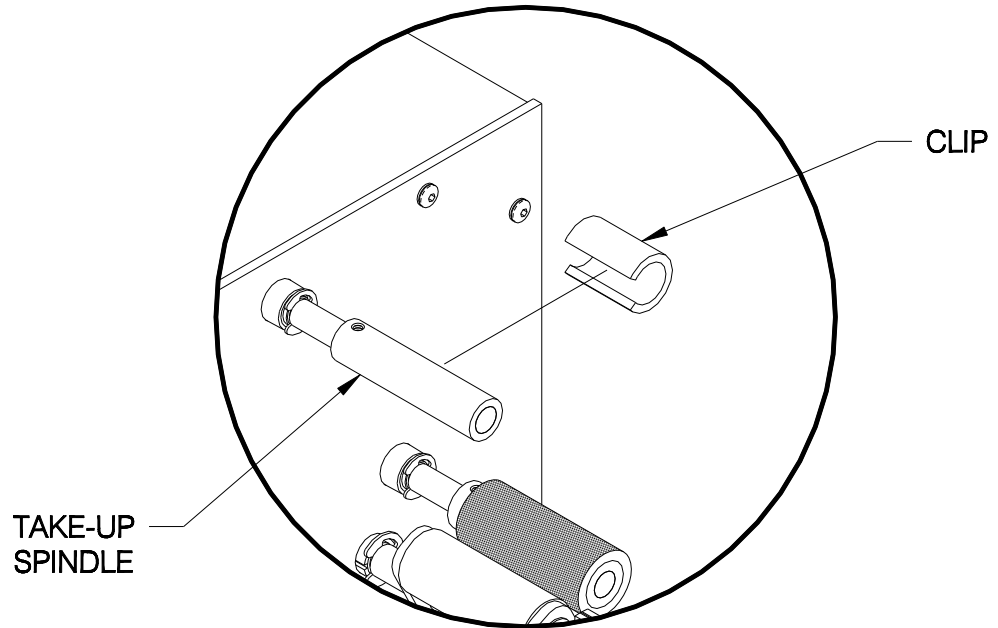

Figure 6.4 - Removing Waste Backing Paper

1. Tear the waste backing paper, leaving enough to reach and wrap around the TAKE-UP SPINDLE.
2. Pull the waste backing paper off the TAKE-UP SPINDLE.
3. Remove the CLIP from the center of the waste backing paper.
4. Place backing paper over the TAKE-UP SPINDLE ASSEMBLY from the input end.
5. Secure the backing paper to the SPINDLE with the CLIP.

TIP

**Have a few extra CLIPS on hand
as they are easy to lose.**

7. MAINTENANCE

7.1 General Cleaning & Clearing

Your FD 260 will need regular cleaning. How often you'll need to clean the FD 260 depends on the amount of paper dust your mail pieces generate. Wipe surface dust or debris from the FD 260 with a damp cloth as necessary.

7.1.1 Removing Tabs & Debris From Peel Point Area

Periodically check for peeled tabs stuck on or near the bottom of the PEEL PLATE. You can see this area by looking through the INSPECTION WINDOW on the input end, below the threading path.

If you use clear tabs, you must remove any tabs stuck in the entire PEEL PLATE area before activating CLEAR TAB.

To remove tabs and debris from peel point area:

WARNING
DO NOT PLACE FINGERS OR TOOLS BETWEEN
OR NEAR MOVING PARTS.

1. Turn the POWER SWITCH off.
2. Reach through the INSPECTION WINDOW and remove all tabs and debris.

7.2 Replacing a Fuse

7.2.1 Line Fuse

When one or both LINE FUSES are blown, the FD 260 will appear to have no power and the LINE FUSE must be replaced.

WARNING
UNPLUG THE POWER CORD BEFORE OPENING THE FUSE DRAWER.

To replace a LINE FUSE:

1. Use a small screwdriver or similar tool to push up on the FUSE DRAWER LOCKING TAB to release this locking tab. (Refer to **Figure 7.1.**)
2. Pull the FUSE DRAWER out of the POWER ENTRY CASING. (Refer to **Figure 7.1.**)

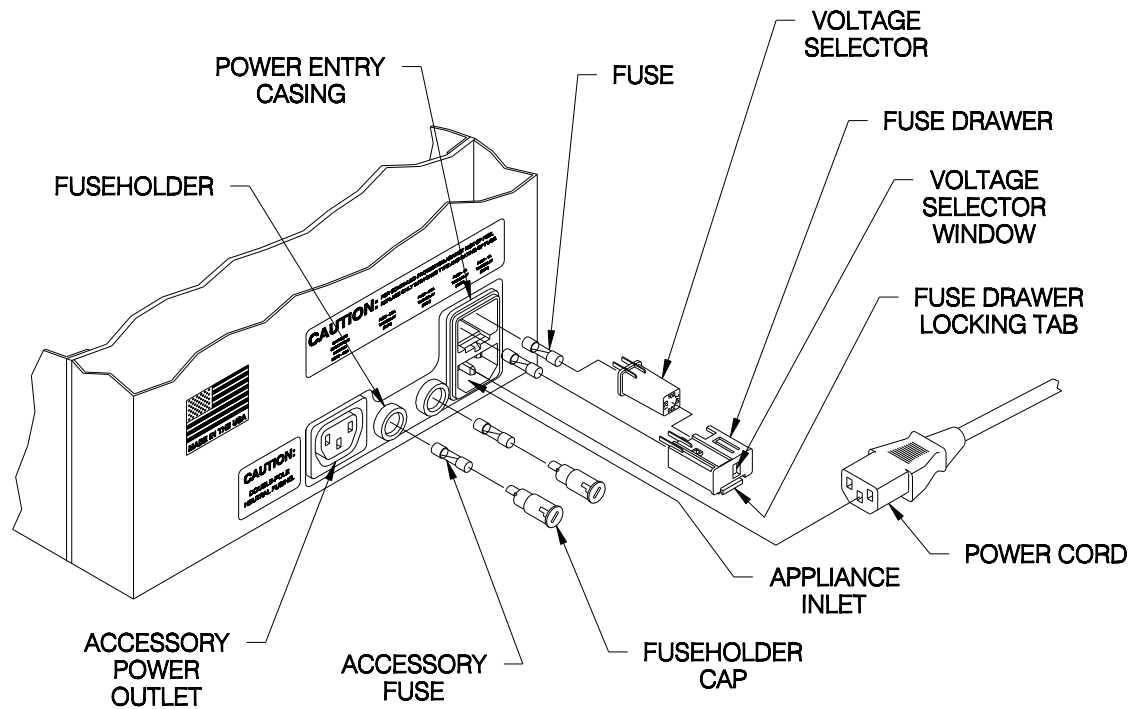

Figure 7.1 – Replacing a Line Fuse

3. Inspect the FUSES; look for blackened glass, melted wire or a disconnected wire between the ends of the tube. If you find any of these problems in either FUSE, that FUSE is blown and must be replaced.
4. Pull the blown FUSE from its slot.

WARNING
REPLACE ONLY WITH SAME TYPE AND RATING OF FUSE. (REFER TO CHART BELOW.)

<u>Selected Voltage</u>	<u>Line Fuse Value</u>
100V.....	1.0A (250V time delay)
120V.....	1.0A (250V time delay)
220V.....	0.5A (250V time delay)
240V (or 230V).....	0.5A (250V time delay)

5. Place the new FUSE into the same slot.
6. Install the FUSE DRAWER. (Refer to **Figure 7.1.**)

7.2.2 Accessory Fuse

When one or both ACCESSORY FUSES are blown, the ACCESSORY POWER OUTLET and the machine plugged into this outlet lose power.

WARNING
UNPLUG THE POWER CORD BEFORE OPENING THE FUSE DRAWER.

To replace an ACCESSORY FUSE:

1. Use a small screwdriver or similar tool to press in and slightly rotate the FUSEHOLDER CAP counterclockwise. (Refer to **Figure 7.1.**)
2. Inspect the FUSE; look for blackened glass, melted wire or a disconnected wire between the ends of the tube. If you find any of these problems in the FUSE, it is blown and must be replaced. If the first FUSE is fine, repeat steps 1 and 2 for the second FUSE.
3. Pull the blown FUSE from its slot.

WARNING
REPLACE ONLY WITH SAME TYPE AND RATING OF FUSE. (REFER TO CHART BELOW.)

<u>Selected Voltage</u>	<u>Line Fuse Value</u>
100V.....	6.3A (250V time delay)
120V.....	6.3A (250V time delay)
220V.....	3.15A (250V time delay)
240V (or 230V).....	3.15A (250V time delay)

4. Place the new FUSE into the same slot.
5. Install the FUSEHOLDER CAP into the FUSEHOLDER. (Refer to **Figure 7.1.**)

8. TROUBLESHOOTING

WARNING
UNPLUG THE POWER CORD BEFORE
REMOVING, ADJUSTING OR REPAIRING ANY
PARTS IN THE
FD 260.

8.1 Troubleshooting Chart

Trouble	Cause	Solution
1. Nothing works.	<ul style="list-style-type: none"> Power switch is not on. 	<ul style="list-style-type: none"> Turn power switch on.
	<ul style="list-style-type: none"> Power cord is damaged or not plugged into proper outlet. 	<ul style="list-style-type: none"> Replace power cord if damaged or plug into proper outlet if necessary.
	<ul style="list-style-type: none"> Outlet does not have power present. 	<ul style="list-style-type: none"> Check circuit source for a blown fuse or circuit breaker.
2. CLEAR TAB light flashes 8-10 seconds after CLEAR TAB is turned on.	<ul style="list-style-type: none"> Sensor is blocked. 	<ul style="list-style-type: none"> Remove all tabs and debris from peel point area. Tune sensor. Refer to Section 9.1.2.
3. No tabs on mail pieces.	<ul style="list-style-type: none"> TAB READY light is off. Peel point is free of tabs and debris. 	<ul style="list-style-type: none"> Toggle ON/OFF until light illuminates.
4. FD 260 shuts down. TAB READY light starts flashing.	<ul style="list-style-type: none"> Sensor could not find tab during the pre-set time. 	<ul style="list-style-type: none"> Tune sensor. Refer to Section 9.1.2.
5. Not tabbing -- TAB READY light remains on, multiple tabs peeled.	<ul style="list-style-type: none"> Incorrect CLEAR TAB selection. 	<ul style="list-style-type: none"> Make CLEAR TAB selection for tabs being run. Refer to Section 9.1.2.
6. Not tabbing -- TAB READY light is on but no tabs at peel point.	<ul style="list-style-type: none"> Sensor is blocked by debris. 	<ul style="list-style-type: none"> Remove debris from the peel point area through the inspection window.

Trouble	Cause	Solution
7. FD 260 stops.	<ul style="list-style-type: none"> Power entry fuse is blown. 	<ul style="list-style-type: none"> Replace blown line fuse. Refer to Section 3.3.
	<ul style="list-style-type: none"> FD 260 keeps blowing fuses after you replace them. 	<ul style="list-style-type: none"> Contact authorized Formax dealer.
	<ul style="list-style-type: none"> Mail piece has jammed in machine. 	<ul style="list-style-type: none"> Clear the jam. Refer to Section 9.1.3.
	<ul style="list-style-type: none"> Backing paper has torn before the drive roll. 	<ul style="list-style-type: none"> Thread tabs from that point on. Refer to Section 9.1.4.
8. Feeding stops.	<ul style="list-style-type: none"> Accessory fuse is blown. 	<ul style="list-style-type: none"> Replace blown accessory fuse. Refer to Section 3.4. If the fuse is not blown, refer to your feeding device manual.
9. Backing paper slack.	<ul style="list-style-type: none"> Backing paper is threaded under the drive roll. 	<ul style="list-style-type: none"> Re-thread tabs. Refer to Section 6.1.
10. Tabbing incorrectly	<ul style="list-style-type: none"> Peel plate assembly is not latched. 	<ul style="list-style-type: none"> Insert and latch peel plate assembly.
11. Multiple tabs on mail piece.	<ul style="list-style-type: none"> Incorrect CLEAR TAB selection. 	<ul style="list-style-type: none"> Make CLEAR TAB selection for tabs being run. Refer to Section 9.1.2.
	<ul style="list-style-type: none"> Incorrect Tab Size setting 	<ul style="list-style-type: none"> Turn Power Off, change tab size switch.
12. Tab placement is inconsistent.	<ul style="list-style-type: none"> Mail pieces are feeding crooked. 	<ul style="list-style-type: none"> Make sure mail pieces feed straight into FD 260. Refer to Section 9.2.1.
	<ul style="list-style-type: none"> Backing paper has torn after the drive roll. 	<ul style="list-style-type: none"> Re-thread backing paper from drive roll. Refer to Section 9.1.4.
13. Tab fold is uneven.	<ul style="list-style-type: none"> Peel plate position needs adjustment. 	<ul style="list-style-type: none"> Adjust peel plate position. Refer to Section 9.2.2.
	<ul style="list-style-type: none"> Tab Size Wrong 	<ul style="list-style-type: none"> Power Off, select tab size

Trouble	Cause	Solution
14. Tab fold is off mail piece.	<ul style="list-style-type: none"> • Sweep position needs adjustment. 	<ul style="list-style-type: none"> • Contact authorized Formax dealer.
15. Leading edge of mail piece tears at the tab.	<ul style="list-style-type: none"> • Sweep position needs adjustment. • Mail pieces are poorly folded. • Mail pieces are too thin. 	<ul style="list-style-type: none"> • Contact authorized Formax dealer.
16. Mail pieces jam upon entering FD 260.	<ul style="list-style-type: none"> • Sweep position requires adjustment. 	<ul style="list-style-type: none"> • Contact authorized Formax dealer.
	<ul style="list-style-type: none"> • Sweep is reversed. 	<ul style="list-style-type: none"> • Slide plastic ruler along feed tray to reverse sweep.
17. Tab does not fold, one tab is folded on multiple mail pieces and/or some mail pieces are not tabbed.	<ul style="list-style-type: none"> • Feeding device is too fast. 	<ul style="list-style-type: none"> • Reduce speed of feeding device until tabs are being applied correctly.
18. Difficulty running translucent tabs	<ul style="list-style-type: none"> • Translucent tabs typically run on the Clear Tab setting 	<ul style="list-style-type: none"> • See Section 9.1.2 to clear machine and turn Sense Clear on.
19. Backing Paper jam	<ul style="list-style-type: none"> • With 1.5 inch tads poor peel bar adjustment 	<ul style="list-style-type: none"> • The Peel Bar needs to be straight. Top and bottom edges must be parallel. Check carefully and correct as necessary.

9. CORRECTING TABBING PROBLEMS

9.1 No Tabs Applied to Mail Pieces

9.1.1 Sensor Could Not Detect Tab

At start-up, when the ON/OFF light is illuminated, the tab strip advances until the sensor detects a tab at the peel point. If no tab is detected, toggle ON/OFF until the TAB READY light illuminates.

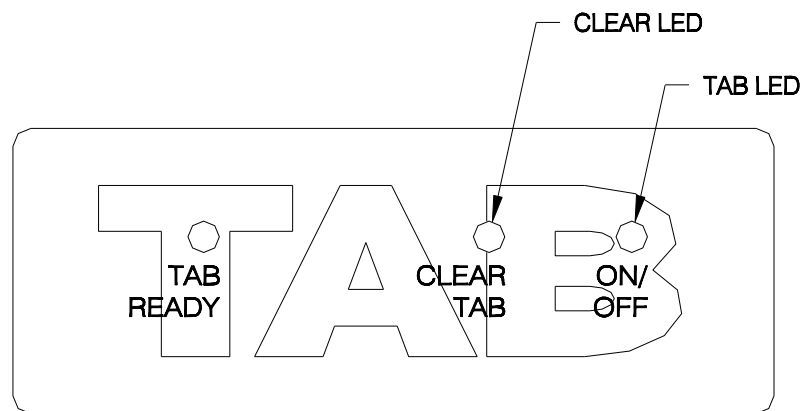

Figure 9.1 – FD 260 Control Panel

9.1.2 Sensor Is Not Tuned for Clear Tabs

If the sensor is not tuned for clear tabs, one of the following problems may occur:

- TAB READY light remains on, but there is more than one tab at the peel point.
- TAB READY light flashes and the tab strip stops advancing after peeling several clear tabs at the peel point.

If you experience either of these problems, tune the sensor for clear tabs:

WARNING
DO NOT PLACE FINGERS OR TOOLS BETWEEN OR NEAR MOVING PARTS.

1. Turn the POWER SWITCH off.
2. Remove any tabs and debris from the peel point area through the INSPECTION WINDOW on the input end, below the threading path.

CAUTION
IF ALL TABS AND DEBRIS ARE NOT REMOVED FROM THE PEEL POINT AREA BEFORE CLEAR TAB IS ACTIVATED, THE SENSOR'S DEFINITION OF CLEAR TABS WILL CHANGE AND CLEAR TABBING WILL BE PREVENTED.

3. Toggle CLEAR TAB off.
4. Toggle CLEAR TAB on.
5. Toggle ON/OFF until a tab advances to the peel point and the TAB READY light illuminates.

9.1.3 Mail Piece Jam

Mail pieces usually jam at the feed rolls or between the belts and metal rolls at the end of the FEED TRAY. Mail pieces can jam if the SWEEP is too high. Mail pieces can be blocked if the SWEEP is not bent on the FEED TRAY. If jamming is caused by the SWEEP, contact an authorized Formax dealer for service.

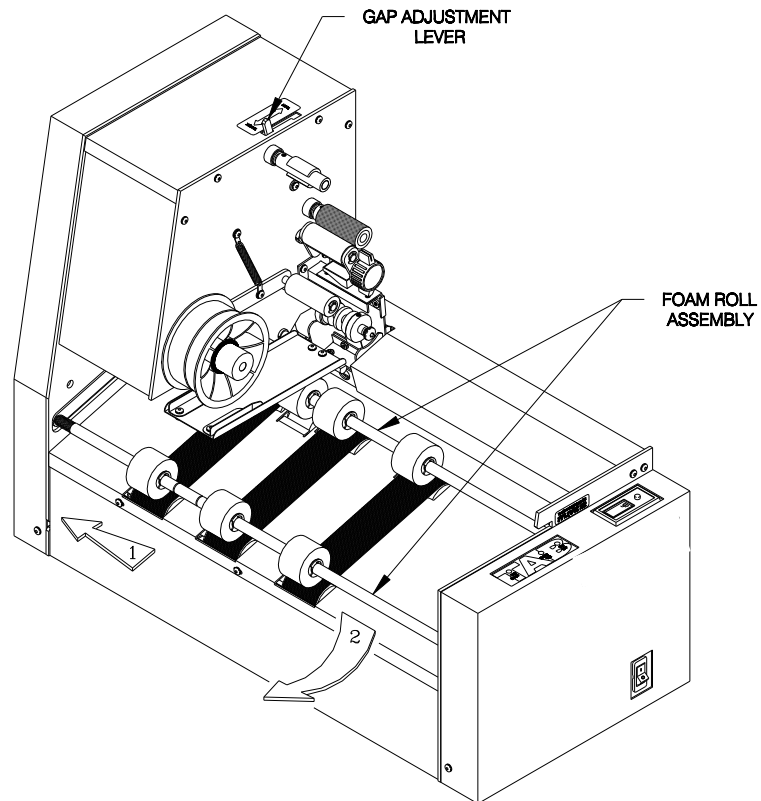

Figure 9.2 – Clearing Jammed Mail Pieces

To clear mail pieces from the feed rolls:

WARNING
DO NOT PLACE FINGERS OR TOOLS BETWEEN OR NEAR MOVING PARTS.

1. Turn the POWER SWITCH off.
2. Pull the jammed mail pieces out in the direction they feed through the FD 260.

CAUTION
PULLING MAIL PIECES IN THE OPPOSITE DIRECTION THAT THEY MOVE THROUGH THE FD 260 MAY DAMAGE THE SWEEP OR MOVE IT OUT OF POSITION.

3. If you cannot reach the jammed mail pieces, continue through the following instructions.
4. Set the GAP ADJUSTMENT LEVER to **thick**, if it is set for **thin**. (Refer to **Figure 9.2**.)
5. Push the FOAM ROLL ASSEMBLY toward the end with the spring attached. Pull out the other end, as you push in the spring end. Make sure the other end clears the side frame. (Refer to **Figure 9.2**.)
6. Remove any mail pieces jammed at the feed rolls.
7. Push the spring-loaded end of the FOAM ROLL ASSEMBLY in its hole in the non-operator side panel. Place the other end of the FOAM ROLL ASSEMBLY into the d-hole in the operator side frame. (Refer to **Figure 9.2**.)
8. Set the GAP ADJUSTMENT LEVER to **thin** if you are tabbing mail pieces thinner than $\frac{1}{8}$ ".

To remove mail pieces jammed between the belts and metal rolls at the end of the FEED TRAY:

WARNING
DO NOT PLACE FINGERS OR TOOLS BETWEEN OR NEAR MOVING PARTS.

1. Turn the POWER SWITCH off.
2. Pull the mail pieces from the feed tray. Make sure all belts are centered on the metal rolls before you resume tabbing.

9.1.4 Torn Backing Paper

If the backing paper tears *before* the drive roll, the FD 260 will stop tabbing but continue feeding. To start tabbing:

WARNING
DO NOT PLACE FINGERS OR TOOLS BETWEEN OR NEAR MOVING PARTS.

1. Turn the POWER SWITCH off.
2. Thread the FD 260 from the point where the backing paper tore. (Refer to **Section 6.1.**)

NOTE
When backing paper is pulled, tabs will peel at the PEEL PLATE until pulling is stopped.

3. Remove any tabs or debris from the peel point area through the INSPECTION WINDOW on the input end, below the threading path.
4. Turn the POWER SWITCH on.
5. Toggle ON/OFF until a tab advances to the peel point and the TAB READY light illuminates.

If the backing paper tears *after* the drive roll, the backing paper may fall away from the FD 260 and tabbing will continue. If the backing paper wraps around rolls in the threading path, tabbing may continue, but tab placement may not be accurate. To continue tabbing accurately:

WARNING
DO NOT PLACE FINGERS OR TOOLS BETWEEN OR NEAR MOVING PARTS.

1. Turn the POWER SWITCH off.
2. Secure the backing paper around the TAKE-UP SPINDLE with the CLIP. You may need to pull the backing paper a little to reach the TAKE-UP SPINDLE.

NOTE

When backing paper is pulled, tabs will peel at the PEEL PLATE until pulling is stopped.

3. Remove any tabs stuck at the PEEL PLATE. Reach the tabs through the INSPECTION WINDOW on the input end, below the threading path.
4. Turn the POWER SWITCH on.
5. Toggle ON/OFF until a tab advances to the peel point and the TAB READY light illuminates.

9.1.5 Incorrect Threading

Threading a tab strip incorrectly can prevent tabbing. Two examples are listed below.

- **PEEL PLATE ASSEMBLY is not latched.** The backing paper will pull the PEEL PLATE assembly out of its slot, tabs will peel in the wrong place, and the PEEL PLATE assembly will block any mail pieces entering the FD 260.
- **Backing paper is threaded under the DRIVE ROLL.** The backing paper will pull backward and no tabs will peel.

Refer to **Section 6.1** for instruction on threading tabs.

9.2 Poor Tab Placement Or Appearance

9.2.1 Tab Placement Is Inconsistent

If tab placement on mail pieces varies during the same run, check to see if mail pieces are feeding straight. Make sure the paper guides on your feeding device are set against the sides of the stack of mail pieces. If mail pieces can move sideways between the paper guides, they will not feed straight.

To check your tab placement:

1. Hold a stack of tabbed mail pieces. Make sure all edges are straight and even, and all tabs are on the same side.
2. Look at the tabbed side of the stack. If the tabs do not form a straight line down the stack, the mail pieces are moving sideways as they enter the FD 260.
3. Set paper guides correctly and securely on the feeding device.

9.2.2 Tab Fold Is Uneven

If tabs are not wrapped evenly around mail pieces, (**Figure 9.3**) either the PEEL PLATE position needs adjustment. or the Tab Size switch setting does not match the tabs being used. Power Off and set tab switch correctly.

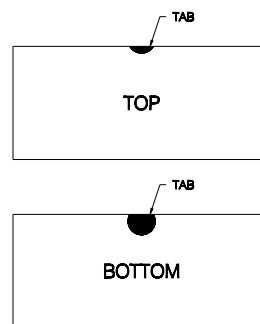

Figure 9.3 – Both Sides of One Mail Piece

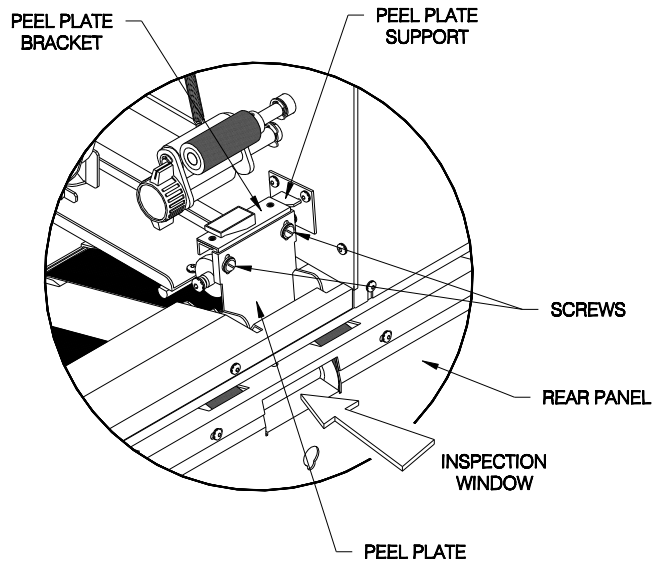

Figure 9.4 – Input End

To adjust the PEEL PLATE position:

WARNING
DO NOT PLACE FINGERS OR TOOLS BETWEEN
OR NEAR MOVING PARTS.

1. Turn the POWER SWITCH off.
2. Remove the PEEL PLATE ASSEMBLY.
3. Loosen the SCREWS on the PEEL PLATE ASSEMBLY with a short, small blade screwdriver. (Refer to **Figure 9.4.**)
4. Slightly move the PEEL PLATE up or down on the PEEL PLATE BRACKET. (Refer to **Figure 9.4.**) Move the PEEL PLATE up to place a larger portion of the tab on the top side of the mail piece. Move the PEEL PLATE down to place a larger portion of the tab on the bottom side of the mail piece.
5. Tighten the SCREWS you loosened in step 3 to secure the PEEL PLATE to the PEEL PLATE BRACKET.
6. Replace the PEEL PLATE ASSEMBLY.
7. Turn the POWER SWITCH on.
8. Feed a few mail pieces through the FD 260 and observe the tab placement. Repeat until the tab has equal portions on the top and bottom of the mail pieces.

9.2.3 Tab Fold Is Off Mail Piece – Tab Is Tenting

If tabs fold too early so the tab fold is not on the mail piece, the SWEEP needs adjusting. If the fold resembles **Figure 9.5**, the SWEEP position is too high. If the fold resembles **Figure 9.6**, the SWEEP position is too low. The SWEEP is a thin piece of white plastic that helps fold the tab onto the mail pieces. It extends below the bottom of the PEEL PLATE. Adjusting the SWEEP will correct the fold but should only be done by a trained service professional.

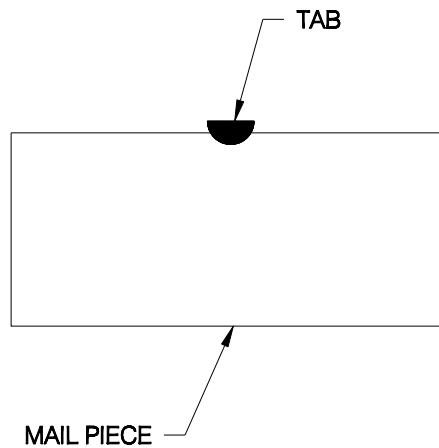

Figure 9.5 - Sweep Position Too High

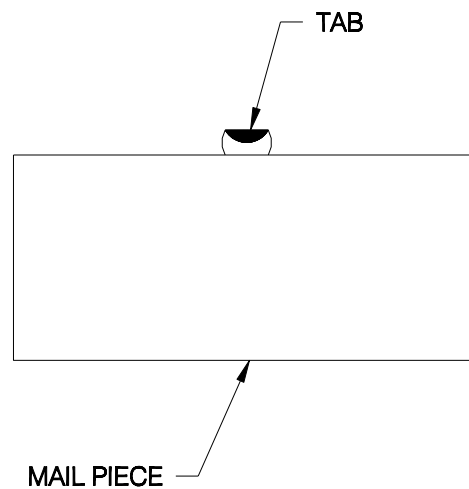

Figure 9.6 - Sweep Position Too Low

Tabs are made of different materials and will fold differently with the same SWEEP position. For example, paper tabs may fold differently than foil tabs. Colored tabs may fold differently than white tabs because ink adds moisture and density. Expect some “tenting” with perforated tabs. Perforated tabs tend to fold on the perf independent of PEEL PLATE position.

The factory pre-set SWEEP position is standard and works with most tabs. If your tabs fold too early or too late, the SWEEP position must be adjusted. Do not attempt this procedure. Contact an authorized FORMAX dealer for service.

9.2.4 More Than One Clear Tab On Mail Piece

The FD 260 may place more than one clear tab on a mail piece if the sensor is not tuned for clear tabs. To correct this, tune the sensor for clear tabs. Refer to **Section 9.1.2.**

10. SERVICE

10.1 Service

If any problems occur with this equipment or if you need assistance installing or operating your FD 260 contact an authorized FORMAX dealer.

10.2 Repacking Instructions

If it is necessary to ship your FD 260 to your authorized Formax dealer for service, pack it in the original shipping container and packaging material. If the original container is not available, the FD 260 should be carefully packed so that it will not be damaged in transit.

When calling for service, have your FD 260's serial number handy.

NOTE

If the FD 260 is packed correctly, your Shipping Carrier is liable for any damages that occur during shipping.

Use the following instructions to pack the FD 260 with commercially available materials.

1. Double wrap the machine in heavy plastic.
2. Use a heavy duty, double-walled container of 350-pound test material.
3. Surround the FD 260 on **ALL** sides with at least 4 to 5 inches of shock absorbing packaging material. This will provide firm cushioning and prevent movement inside the container.
4. Seal the top and bottom of the shipping container with strong tape or banding material.
5. Clearly and legibly mark the shipping container **FRAGILE**.
6. Contact your authorized Formax Dealer.