

# FORMAX<sup>®</sup>

---

Atlas C150  
Automatic Air-Feed Programmable Creaser

 **WARNING**

**This is a Class A product. In a domestic environment this product may cause radio interference in which case the user may be required to take adequate measures. The product (System) which is connected to this machine will be class A.**

 **NOTE**

*The domestic environment is an environment where the use of broadcast radio and television receivers may be expected within a distance of 10 m of the apparatus concerned.*

# Introduction

This manual contains instructions on the operation and maintenance of this machine. To get the maximum versatility from this machine all operators should carefully read and follow the instructions in this manual. Keep this manual in a handy place near the machine.

Please read the Safety Information before using this machine. It contains information related to USER SAFETY and PREVENTING EQUIPMENT PROBLEMS.

## How to Read This Manual

### Notation Conventions

Whenever necessary, the following points for attention are indicated in this manual.

#### **WARNING**

**Indicates a potentially hazardous situation which, if instructions are not followed, could result in death or serious injury.**

#### **CAUTION**

*Indicates a potentiality hazardous situation which, if instructions are not followed, may result in minor or moderate injury or damage to machine or property.*

#### **NOTE**

*This sign refers to:*

- *Remarks for making the operation much easier. You get practical hints or knowledge to assist you in the machine operation such as:*
- *Preparations required before operating*
  - *How to prevent papers from being misfed or damaged*
  - *Precautions required or actions to take after misoperation*
- *Limitations like numerical limits, functions that cannot be used together or conditions under which a particular function cannot be used or obtained.*

# Safety Information

When using this machine, the following safety precautions should always be followed.

## Safety During Operation



### WARNING

- To avoid hazardous situations such as electric shock or danger while exposed to moving, rotating or cutting devices, do not remove any covers, guards or screws other than those specified in this manual.
- Turn off the power and disconnect the power plug (by pulling the plug, not the cable) if any of the following conditions exist:
  - Before disassembling or assembling parts of the System and peripherals.
  - You drop objects or spill something into the equipment.
  - You suspect that your equipment needs service or repair.
  - Machine covers have been damaged
  - You notice unusual noises or odours when operating the equipment.
  - If the power cable or plug becomes worn out or otherwise damaged.
  - Before cleaning and care (unless otherwise specifically instructed).
- Electromagnetic compliance:
  - This is a Class A product. In a domestic environment this product may cause radio interference in which case the user may be required to take adequate measures.
  - The product (System) which is connected to this machine will be class A.

## General Safety



### WARNING

- Always connect the equipment to a properly grounded power source (wall outlet). Wall outlet should be located near the system and easily accessible. If in doubt, have the power source checked by a qualified electrician.
- Improper grounding of the equipment can result in electrical shock. Never connect the machine to a power source that lacks a ground connection terminal. This machine is destined for specific purpose only. Any use going beyond this specific purpose is regarded as beyond the determination. The manufacturer will not be liable for damages resulting from any use beyond the determination, unallowed operation, respectively. The user alone bears the risk.
- Do not make arbitrary changes or modifications to the machine. The manufacturer will not be liable for modifications made at the machine on your own and damages resulting thereof. EC declaration of conformity and the mark CE will be invalidated if you make changes to the machine or to individual components.
- Do not override or bypass electrical or mechanical interlock devices.
- The machine is to be used only by authorized and instructed persons. The responsibilities on operating the machine have to be strictly laid down and observed so that there are no unclear competences regarding safety aspects.
- Vent holes serve for air circulation to protect the machine from overheating. Make sure that the holes are not covered.
- Do not expose fingers or other parts of the body to moving, rotating or cutting devices, e.g. between upper and lower trimmer knives.
- Always locate the equipment on a solid support surface with adequate strength for the weight of the machine.

 **CAUTION:**

- *The machine and its peripherals must be installed and maintained by a customer service representative who has completed the training course on those models.*
- *Always follow all warnings marked on, or supplied with, the equipment.*
- *When you disconnect the power plug from the wall outlet, always pull the plug (not the cable).*
- *Disconnect the power cord before you move the machine. While moving the machine, always exercise care and make sure that the power cord will not be damaged under the machine.*
- *Always contact service if relocating the equipment.*
- *Do not move the machine while the machine is running.*
- *Do not open covers while the machine is running.*
- *Do not switch off the power while the machine is running. Make sure the machine cycle has ended.*
- *Lay the power cord in a way that nobody will stumble over it. Do not place things on the cord.*
- *Never attempt any maintenance function that is not specifically described in this documentation.*
- *Always keep magnets and all devices with strong magnetic fields away from the machine.*
- *If the place of installation is air-conditioned or heated, do not place the machine where it will be:*
  - *Subject to sudden temperature changes.*
  - *Directly exposed to cool air from an air-conditioner.*
  - *Directly exposed to heat from a heater.*
- *If the machine is not used over an extended period of time it should be unplugged to prevent damage in the case of overload.*

 **NOTE:**

- *The operator manual always has to be available at the place of use of the machine.*
- *In the interest of technical development, the company reserves the right to make alterations to specifications without prior notice.*

Page intentionally blank.

# TABLE OF CONTENTS

Introduction .....	3
How to Read This Manual .....	3
Notation Conventions .....	3
Safety Information .....	4
Safety During Operation .....	4
General Safety .....	4
<b>TABLE OF CONTENTS .....</b>	<b>7</b>
<b>What You Can Do with This Machine .....</b>	<b>9</b>
Guide to Components .....	10
Atlas C150 .....	10
Feeder Module .....	11
Creaser Module .....	12
User Interface .....	13
Tools and Accessories .....	14
Optional Parts .....	15
<b>1 Basics .....</b>	<b>17</b>
Paper .....	17
Paper Guidelines .....	17
Creasing .....	18
About the Crease .....	18
Choose the Correct Blade Set .....	19
Replacing Blade Sets .....	20
Adjusting Crease Depth .....	23
Setting Crease Tilt Knob .....	24
Perforation .....	26
About Perforation .....	26
Rotary Perforation .....	27
Cross Perforation .....	31
Blade removal / replacement .....	31
Anvil strip removal / replacement .....	34
Perforation depth adjustment procedure .....	36
<b>2 Setting Up a Job .....</b>	<b>37</b>
Getting Started .....	37
Turning the Machine On and Off .....	37
Paper Stack Preparation .....	38
Loading Paper .....	40
Feeder Table Extension .....	43
The Home Screen .....	44
Overview .....	44
Paper Size .....	45
Pre-set Patterns .....	47
Custom Job .....	49
Saving and Loading Jobs .....	50
Counters .....	51
The Tools Screen .....	52
Overview .....	52
Feeder Settings .....	53
Feeder Settings - advanced .....	54
Clear Jams .....	55
Change Crease Blades .....	56
Export files to USB .....	57
Import jobs from USB .....	58
Checking the Installed Software .....	59

<b>3</b>	<b>Troubleshooting.....</b>	<b>60</b>
	Misfeeds / Jams .....	60
	General.....	60
	Misfeed / Jam in the Feeder .....	60
	Misfeed / Jam in the Creaser .....	60
	Fault Codes .....	61
	General.....	61
	List of Fault Codes.....	62
	Accuracy Checks .....	68
	Module Alignment Check.....	68
	Separation Pad Check.....	70
	Creaser Calibration Check.....	71
	How to Get Support .....	72
<b>4</b>	<b>Remarks.....</b>	<b>74</b>
	Do's and Don'ts .....	74
	Where to Put Your Machine .....	75
	Machine Environment.....	75
	Power Connection .....	75
	Access to Machine.....	76
	Maintaining Your Machine.....	77
	Recommended Weekly Operator Maintenance.....	77
	Limitations of the Atlas C150.....	79
<b>5</b>	<b>Specifications .....</b>	<b>80</b>
	Machine Specification .....	80
	General.....	80
	Physical Characteristics.....	80
	Paper handling .....	80
	Output Quality.....	82
	EU DECLARATION OF CONFORMITY <sup>[1]</sup> .....	83

---

## What You Can Do with This Machine

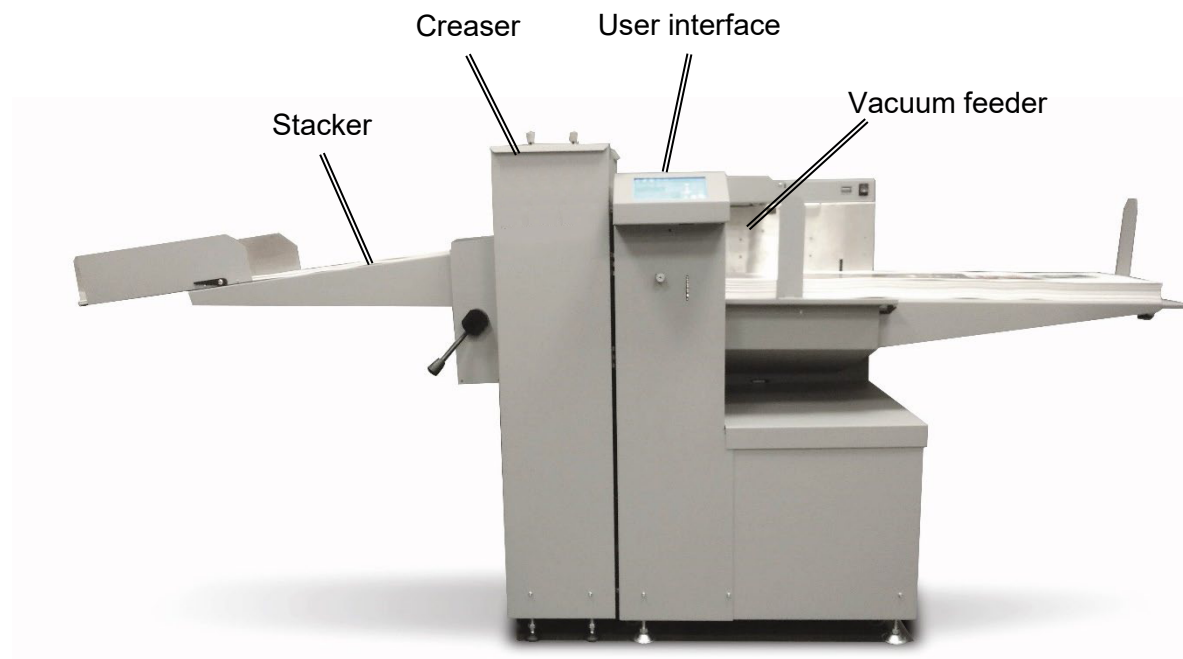

The Atlas C150 is a state-of-the-art paper creasing system. Having a good crease is key to producing perfect folded jobs such as brochures, leaflets and invitations. Creasing ensures the fold is square and the printed image does not crack when folding, giving the job a premium finish.

This machine can accurately crease up to 8500 A4 sheets per hour. The process starts with the automatic vacuum feeder, which uses air knives together with advanced sensing to separate, feed and accurately register sheets ranging from 93 x 210 mm (3.67" x 8.27") all the way up to 385 x 1300 mm (15.16" x 51.2"). The sheets are then creased by a powerful static creaser equipped with quick-swap creasing matrices. Additionally, the sheets can be perforated along or (optionally) across process direction. Finally, the finished products are fed out on a height-adjustable stacking tray.

An option is available to upgrade the Atlas C150 with an additional static creaser to produce up and down creases in a single pass to rapidly create high quality products such as creased covers for PUR bound books.

---

# Guide to Components

---

## Atlas C150

---

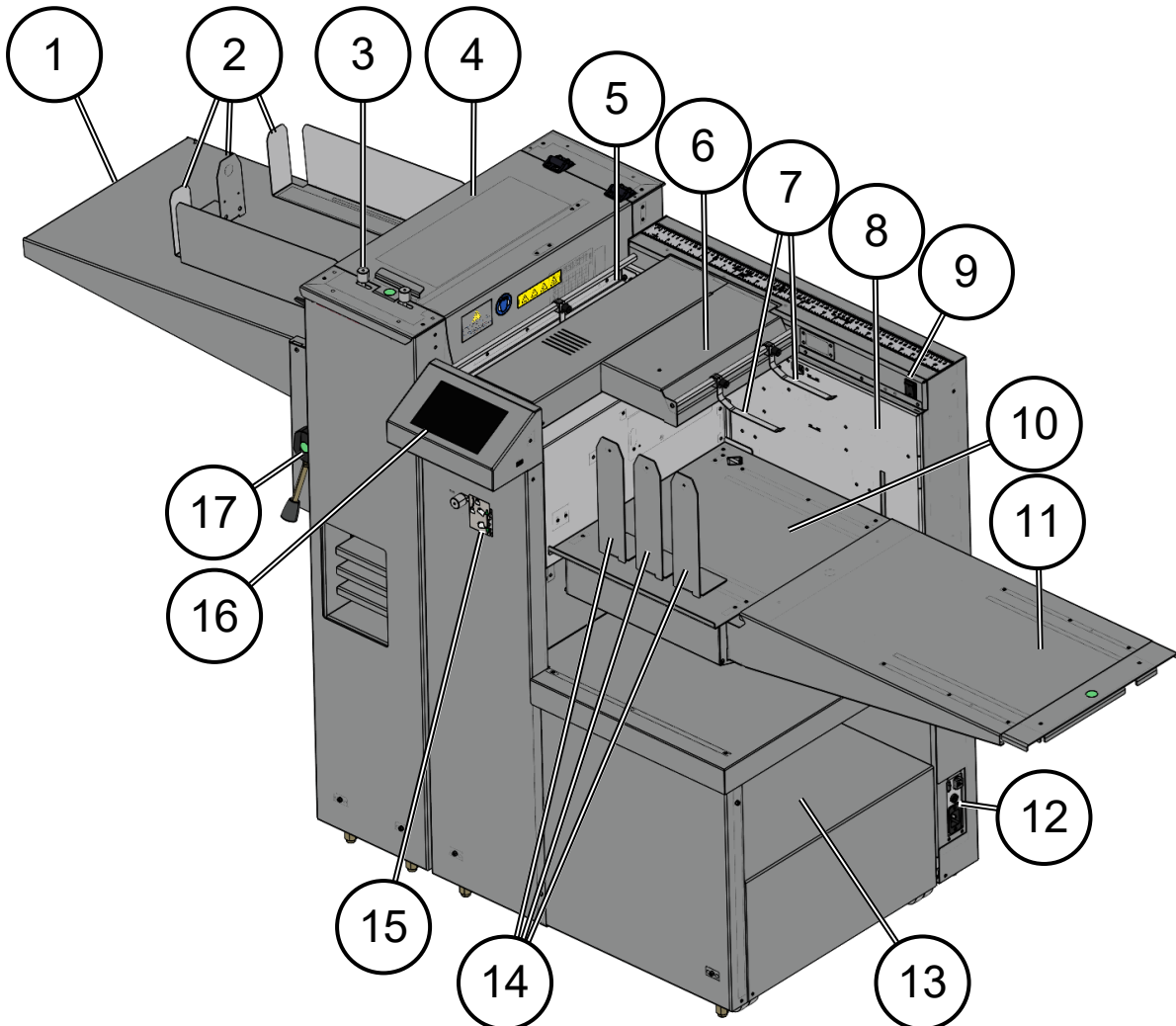

- |                           |                               |
|---------------------------|-------------------------------|
| 1. Stacker                | 11. Paper table extension     |
| 2. Stacker paper guides   | 12. Power inlet and fuse      |
| 3. Crease skew adjustment | 13. Storage shelf             |
| 4. Top cover              | 14. Magnetic paper guides     |
| 5. Registration area      | 15. Feeder skew adjustment    |
| 6. Vacuum belts           | 16. User interface (UI)       |
| 7. Paper guide tongues    | 17. Stacker height adjustment |
| 8. Paper wall             |                               |
| 9. Power switch           |                               |
| 10. Paper table           |                               |

## Feeder Module

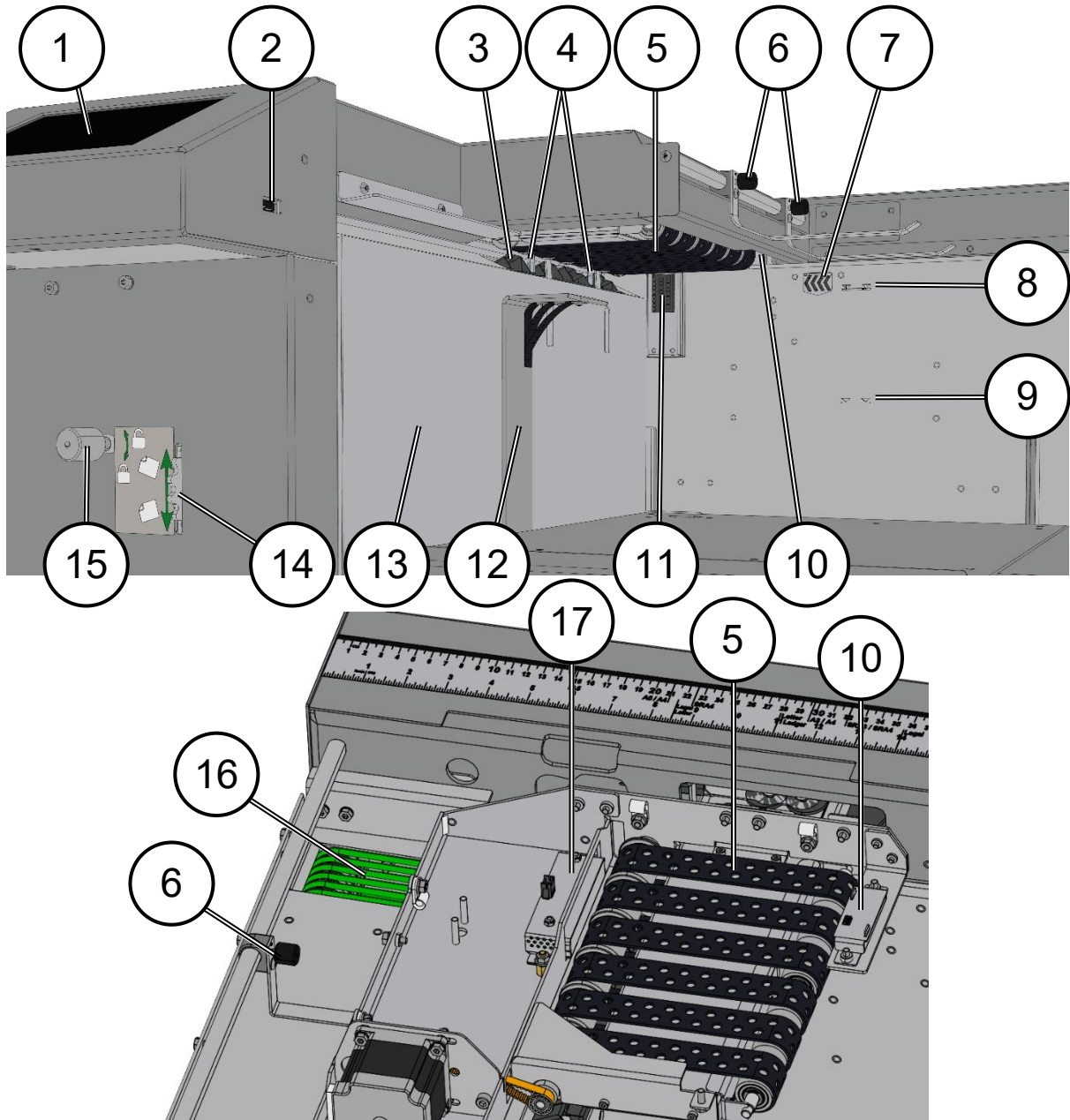

- |  |  |
|--|--|
| <ol style="list-style-type: none"> <li>1. User interface (UI)</li> <li>2. USB port for software updates</li> <li>3. Front separation fan</li> <li>4. Paper separation pads</li> <li>5. Vacuum belts</li> <li>6. Paper guide tongues</li> <li>7. Side float fan</li> <li>8. Maximum paper stack height for sheets shorter than 700 mm (27.6")</li> <li>9. Maximum paper stack height for sheets longer than 700 mm (27.6")</li> <li>10. Paper stack height sensor Q4</li> </ol> | <ol style="list-style-type: none"> <li>11. Separated paper (SP) sensor Q12</li> <li>12. Front paper guide (Tag 8)</li> <li>13. Magnetic front plate (Tag 7)</li> <li>14. Feeder skew adjustment wheel</li> <li>15. Feeder skew adjustment locking knob</li> <li>16. Registration (alignment) belts</li> <li>17. Ultrasonic double sheet detector (US DSD) Q10</li> </ol> |
|--|--|

---

## Creaser Module

---

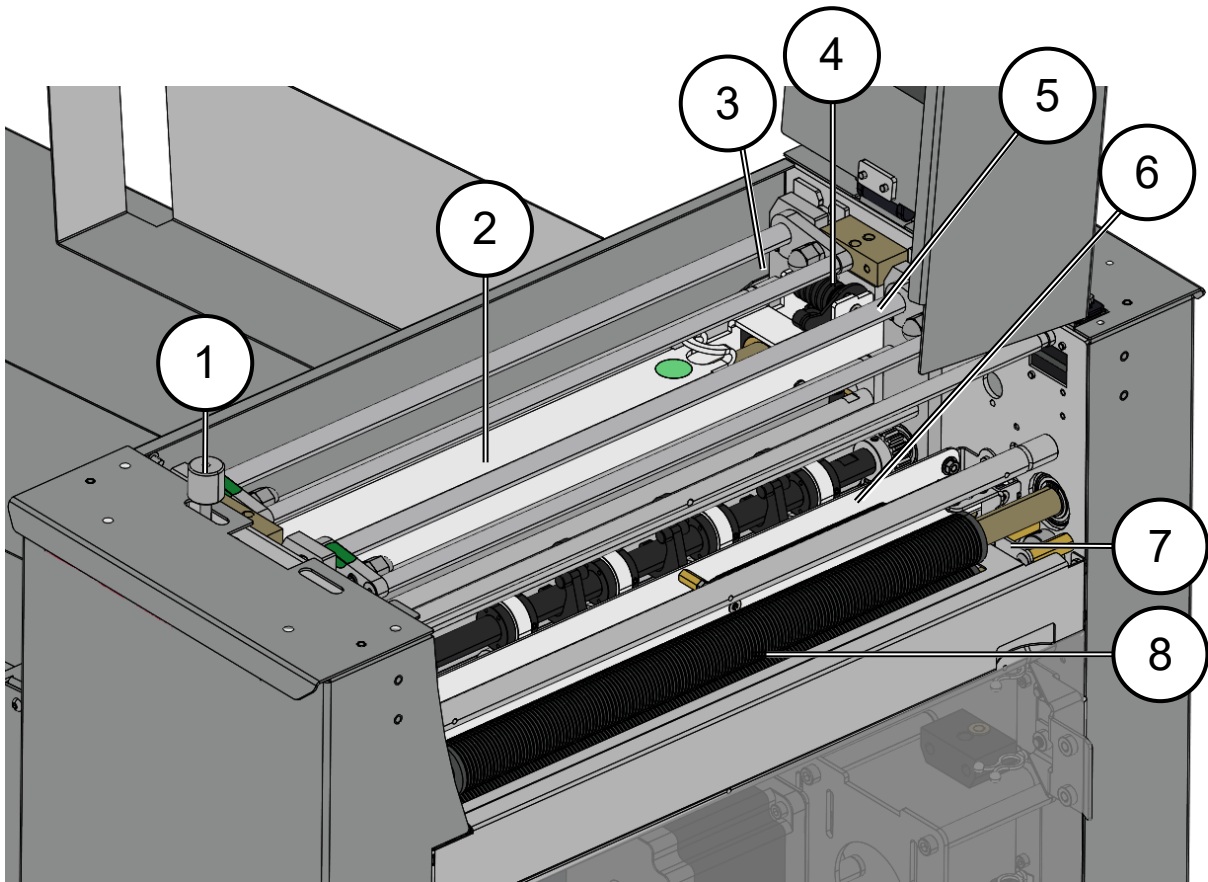

1. Crease skew adjustment knob
2. Static creaser
3. Creaser exit sensor Q25
4. Crease depth adjustment lever
5. Rotary tool carrier
6. Paper path – can be replaced with another static creaser
7. Creaser input sensor Q20
8. Input rollers

---

## User Interface

---

The Atlas C150 has a Graphical User Interface (GUI) which allows for setting up jobs and viewing / modifying machine settings and properties. Detailed descriptions of each menu and sub-menu are found in Section 2 of this Operator Manual.

 **NOTE:**

*Depending on modules and features installed, the screen may look different from what you see here. Some functions may be greyed out or not visible at all and remaining buttons will stretch to fit the screen. This manual will most often show a fully configured system.*

The control panel is of touch screen type. Point at the screen and press the “button” to reach the desired function or change the desired setting.

The Home screen displays paper and job parameters. The operator can start, edit, pause or abort the job from this screen.

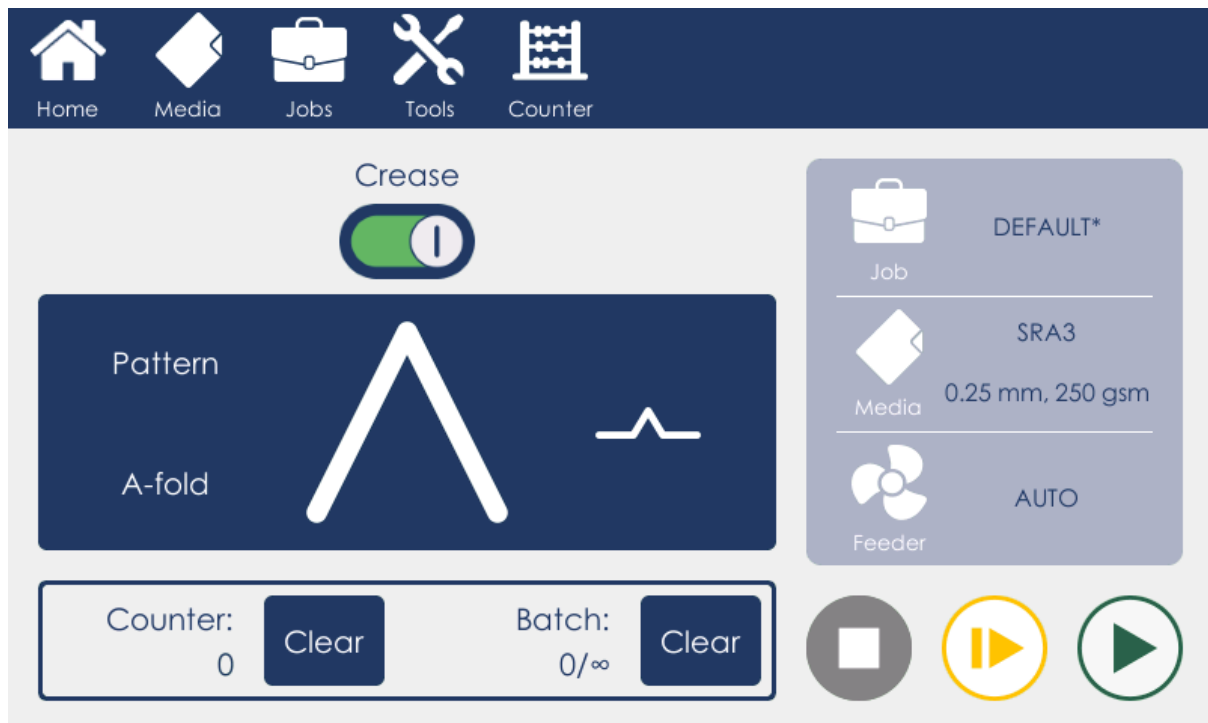

To get started:

1. Load paper in the feeder tray and choose the correct paper size by clicking the Media button from the top menu.
2. Choose the desired pre-set by clicking the Pattern button on the Home screen.
3. Press the Play button to start the machine cycle.

---

## Tools and Accessories

The following tools and accessories are included with the Atlas C150.

<b>Component no</b>	<b>Description</b>
601-167	Digital thickness gauge
1-99-12	28T rotary perforation blade (7 TPI)
1-99-35	Rotary perforation / slitting anvil
201-111686	Screwdriver torx T20
201-111685	Hex wrench kit
601-185	Sensor cleaning brush
601-118	Roller cleaning brush

## Optional Parts

Several upgrades and optional tools are available to increase the performance of your Atlas C150. Please contact your Dealer for additional information and pricing.

Component no	Description
Upgrade kits:	
AC-150-10	Additional Static Creaser Kit
Blade kits:	
AC-150-20	Standard Static Creaser Blade (1.2 mm)
AC-150-30	Narrow Static Creaser Blade (1.0 mm)
AC-150-40	Extra Narrow Static Creaser Blade (0.7 mm)
AC-150-50	Cross-perforation Blade (7 & 14 TPI)
Rotary tools:	
14200011	Additional Rotary Tool Carrier Kit
AC-75	20T Rotary Perforation Blade (5 TPI)
AC-76	28T Rotary Perforation Blade (7 TPI)
CALL	Rotary Slitting Blade
CALL	Rotary Perforation / Slitting Anvil
AC-77	56T Rotary Perforation Blade (14 TPI)
AC-78	96T Rotary Perforation Blade (24 TPI)
CALL	Scorer Type A (Light Score)
CALL	Scorer Type B (Heavy Score)
CALL	Scorer Type C (Very Hard Materials)
CALL	Scorer Type D (Pre-Fold Pencil Score)

The Atlas C150 is supplied with a single static creasing unit. An additional static creaser can be fitted to this machine. This enables up/down creasing in a single pass and (with the cross-perforation kit) creasing and cross-perforation in a single pass.

Rotary tools allow the Atlas C150 to perforate, slit or score work in the process direction. This machine is supplied with a rotary tool carrier and a single rotary perforation blade (28 teeth, 7 teeth per inch (TPI)). Additional rotary blades as well as scorers are available for purchase. To enable quick changeovers between rotary tool setups additional rotary tool carriers are available.



Page intentionally blank.

---

# 1 Basics

## Paper

---

### Paper Guidelines

---

1

Paper comes in many different makes, types and finishes. There are many ways to print on the paper and then protect that printed image. The grain direction, fiber structure, substrate thickness, porosity, coating type, bond strength of the coating, water content, relative humidity and many other things can affect how the paper will behave when you crease and fold it. We recommend that you learn to identify these differences. Be prepared to make small adjustments to the machine to stop any problems that they might cause.

#### **Guidelines:**

- Always make sure that the sheets of paper you use are cut square. This machine is designed to crease the paper at right-angles. It cannot do this if the paper edges are not cut at 90° angles to each other.
- Always make sure that all of the paper for a job is cut the same. This machine uses the sheet length that you set to automatically set the crease positions on a document. The document will not be accurate if the paper length is not set correctly, or if the length of the paper changes during a job.

---

# Creasing

---

## About the Crease

---

1

A crease stops the paper and printed image of a document from cracking when it is folded. The crease is made when a sheet of paper is compressed between the two parts of a mechanism known as a blade set. The blade set uses an ANVIL and a BLADE to form the crease. A powerful motor operates the blade set so that it can put a large amount of pressure on the paper. This pressure compresses the substrate and printed image, which makes the paper thin and weak along the edges of the crease. This allows the paper to fold accurately along the crease.

 **NOTE:**

*When you crease and fold, the crease is the most important process. The paper will not fold accurately if the crease is not made correctly, or if it is not made in the correct position.*

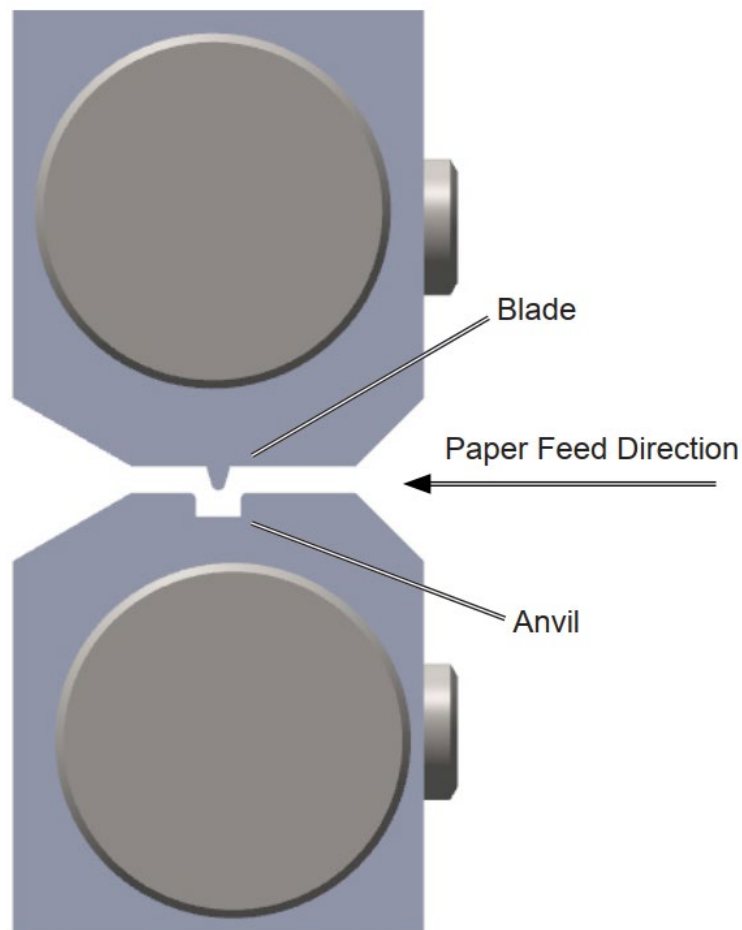

---

---

## Choose the Correct Blade Set

---

This machine is supplied with a single standard crease blade set. Several optional blade sets are available. Refer to the table below to see which type of blade set is most suitable for your job.

Sheet Thickness	Blade Set	Crease Width
≥ 0.25 mm (≥ 0.010")	Standard (supplied with machine) AC-150-20	1.3 mm (0.051")
≤ 0.25 mm (≤ 0.010")	Narrow (optional) AC-150-30	1.0 mm (0.039")
0.09 mm - 0.2 mm (0.0035" - 0.008")	Extra Narrow (optional) AC-150-40	0.7 mm (0.027")

1

The Standard blade set is designed to give a good crease on thick paper and thin card. To do this, it makes a wide crease. A wide crease is necessary because it gives sufficient material at the spine of the fold.

The Narrow blade set is designed to give a good crease on medium and thin paper. To do this it makes a narrower crease than the Standard blade set does. A narrower crease is necessary because if there is too much material at the spine of the fold, the fold might not be accurate or square.

An Extra Narrow blade set is also available for purchase. The Extra Narrow blade set is designed to make a very narrow crease. One should use an extra narrow blade set if folding very thin paper (paper thickness close to the minimum specification for this machine).

Always make sure you have the correct blade set installed before starting a job. When running into creasing or folding problems, try a different blade set. This can help solve the problem, even if it is not the usual blade set that is recommended.

Additionally, the crease blade set may be replaced with an optional perforation blade set.

Sheet Thickness	Blade Set	Perforation
0.09 mm - 0.4 mm (0.0035" - 0.016")	Cross-perforation (optional) AC-150-50	Coarse (7 TPI) or fine (14 TPI) teeth. Full cross perforation or partial cross perforation



### NOTE:

For blade set replacement instructions, see the "Replacing Blade Sets" section within this manual.

---

## Replacing Blade Sets

---

This machine is supplied with a single Standard crease blade set. The blade set can be rotated to produce up or down facing creases without flipping the stack of paper.

 **NOTE:**

Optional blade sets to produce narrower creases or to cross perforate are available (see the “Choose the Correct Blade Set” section within this manual).

To flip the crease blade set or replace it with another set:

1. Open the top cover.
2. Push down the Bridge Assembly (in red) in the spot indicated by the arrow [A] to unhook it.

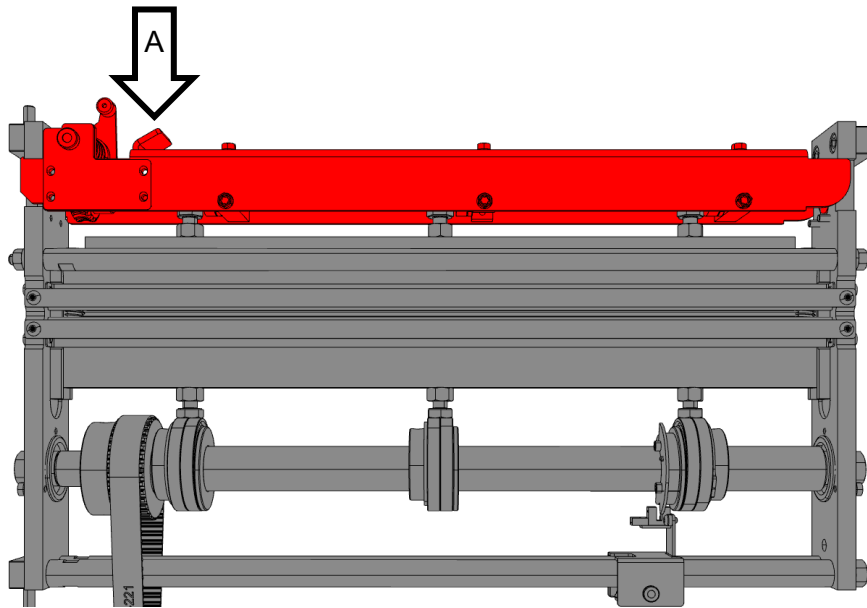

3. While pushing down, pull the Bridge Assembly towards the operator side [B]

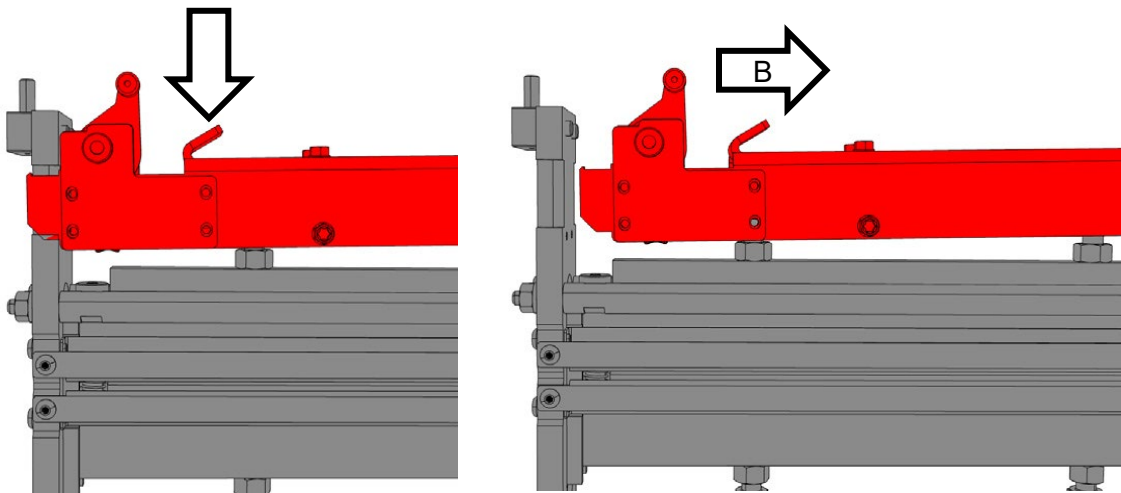

4. Lift the Bridge Assembly up and remove it.

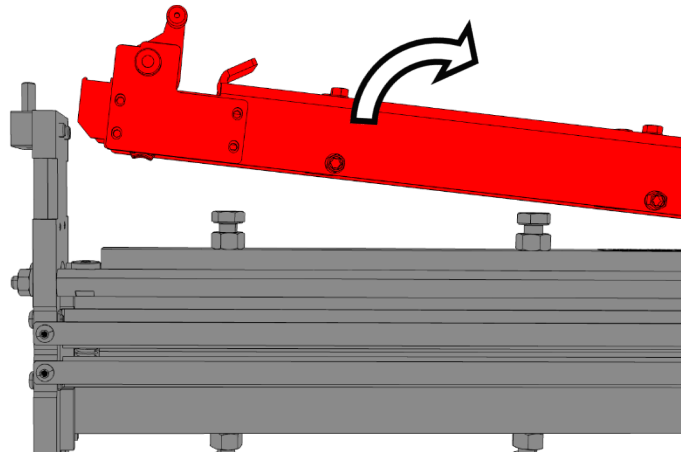

1

5. Pull the blade set upwards to remove it.

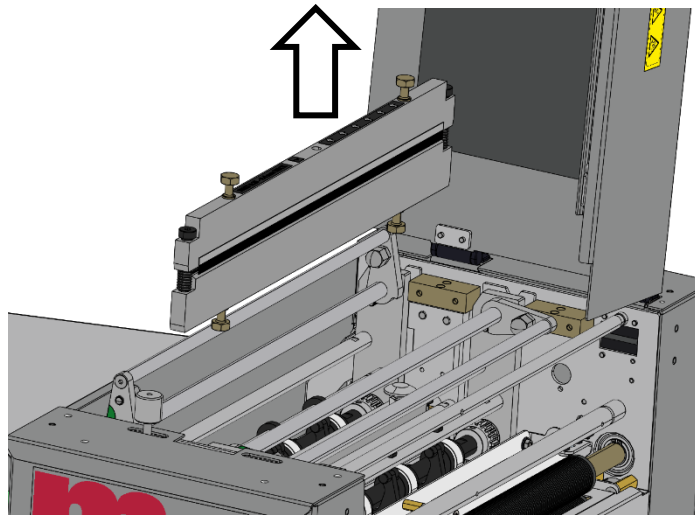

6. Insert the new blade set.

 **NOTE:**

*A label on the blade set indicates paper movement direction. Ensure the blade set is installed in the correct direction. Installing the blade backwards may result in poor crease quality and paper jams.*

7. Reinstall the bridge assembly and ensure it locks into place.

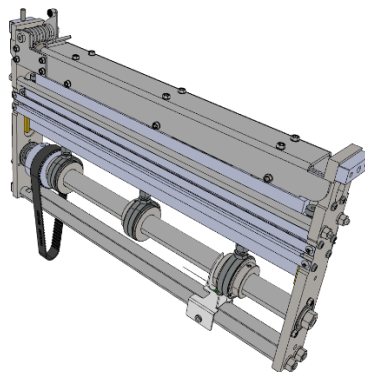

8. Close the top cover.

9. From the touchscreen interface choose Tools -> Change Crease Blades.

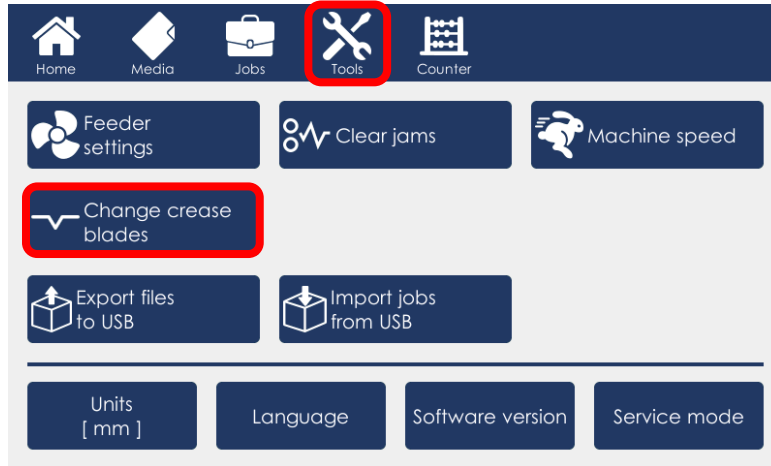

1

10. Use this menu to choose the blade set that has just been installed and set its direction (crease up or crease down). Click the green tick mark to confirm.

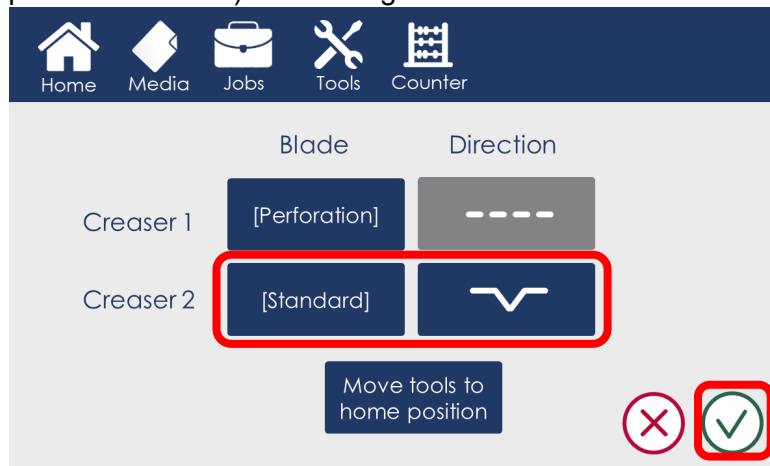

## Adjusting Crease Depth

1. Run a proof sheet and inspect the output.

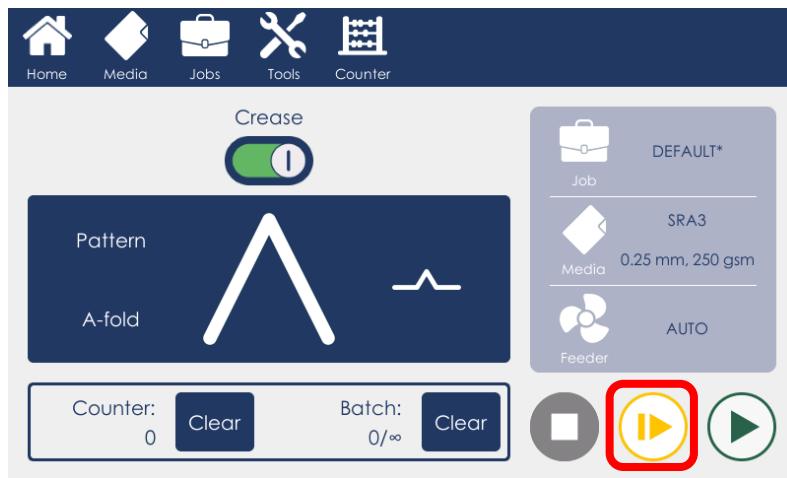

1

2. If the crease is too shallow or too deep use the adjustment lever on the Blade bridge as shown (A – shallower crease, B – deeper crease).

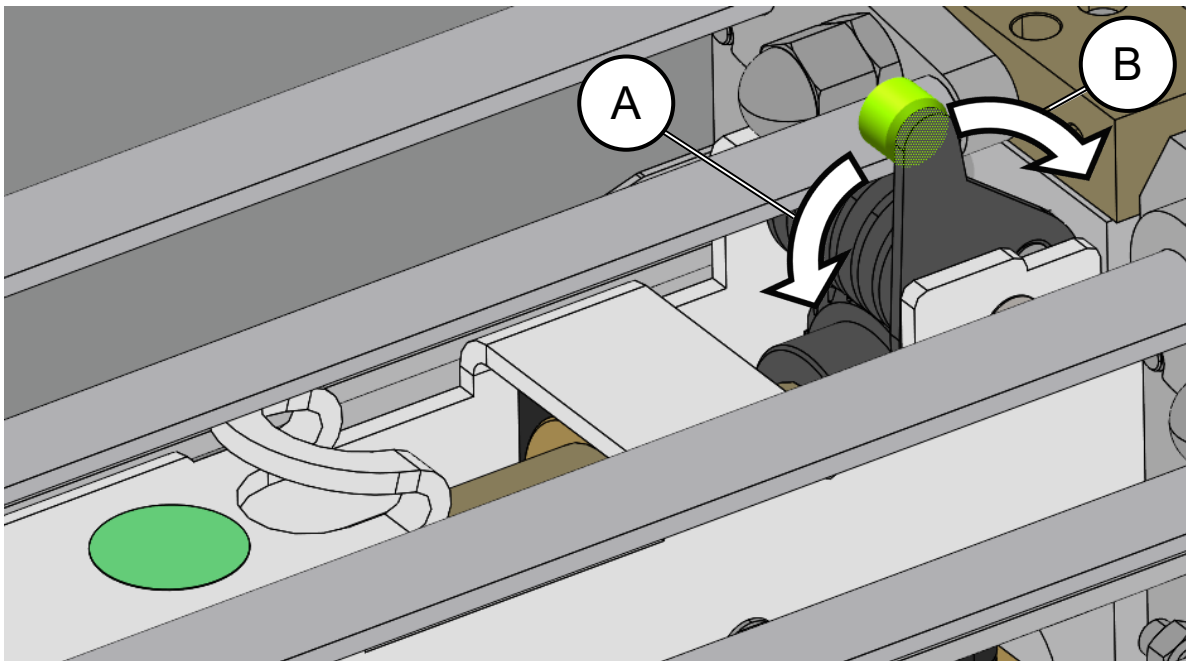

## Setting Crease Tilt Knob

1. Run a proof sheet with a single crease and inspect the output.

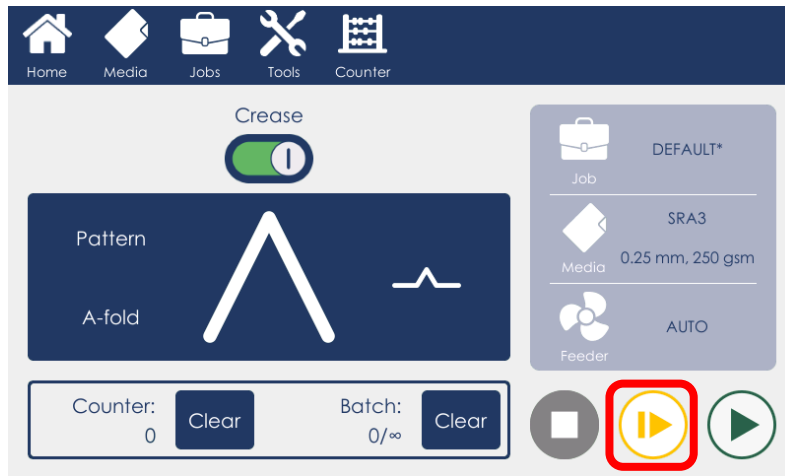

2. If the crease is skew, adjustment is necessary.

**NOTE:**

*Wrong crease positions are marked in red, correct crease position is marked in green.*

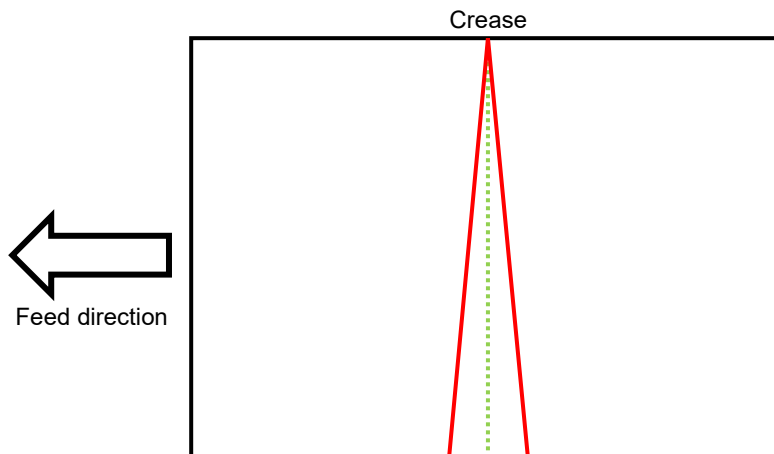

3. To adjust crease skew, loosen the crease adjustment knob by rotating it counterclockwise.

**NOTE:**

*In the below image the optional additional static creaser is shown.*

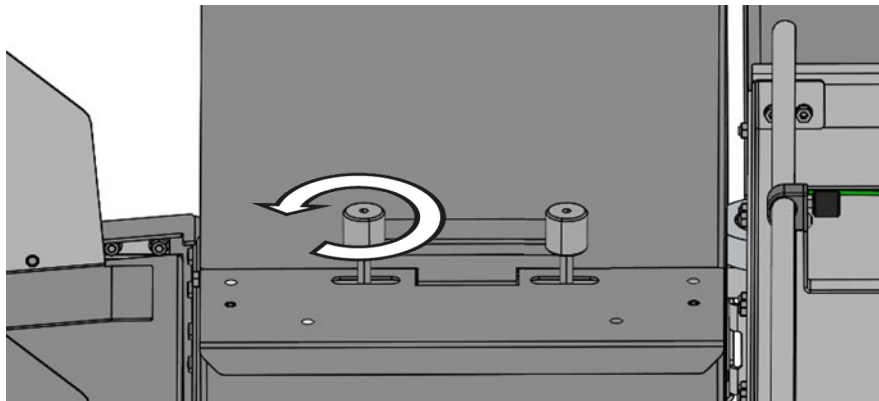

- 
4. Move the knob slightly, either to the left or to the right depending on the direction of the crease skew.

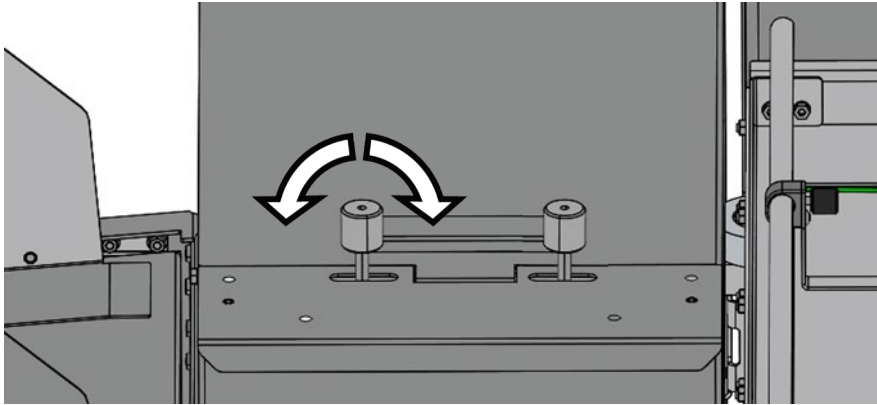

1

5. Rotate the knob clockwise to secure it.
6. Run another proof sheet to check if the crease is now perpendicular to sheet edge. Repeat steps 2 to 5 if necessary.

---

# Perforation

---

## About Perforation

---

1

A perforation is a series of cuts in the paper that allows it to be easily and neatly separated into two or more pieces. Perforation can be used to create coupons, tickets, return slips and other products.

The Atlas C150 can perforate sheets in two perpendicular directions:

- In the process direction using rotary tools
- Across the process direction using the optional cross-perforation kit

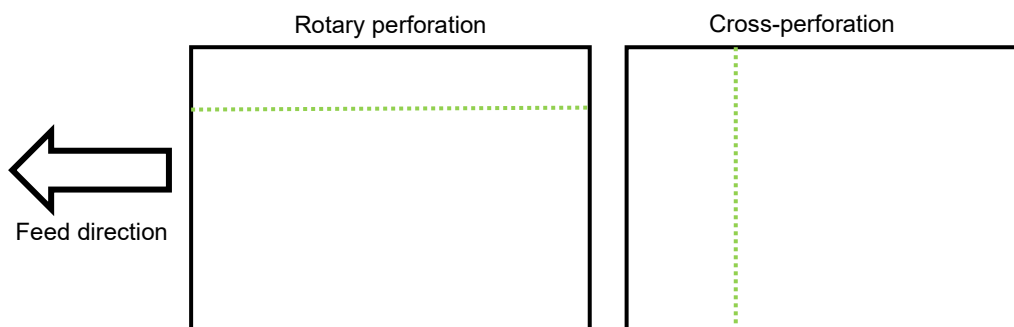

Depending on paper type and the desired finish several different perforation types are available with varying number of teeth per inch (TPI):

5 TPI, 0.8 mm (0.031") tie width – rotary 20T

---

7 TPI, 0.8 mm (0.031") tie width – rotary 28T – cross-perforation "coarse"

---

14 TPI, 0.8 mm (0.031") tie width – rotary 56T – cross-perforation "fine"

---

24 TPI, 0.8 mm (0.031") tie width – rotary 96T

---

# Rotary Perforation

The rotary perforation process uses circular blades mounted on the rotary tool carrier to perforate sheets in the process direction.

 **NOTE:**

1. Perforation and creasing can be carried out simultaneously. However, if any skew adjustment is made to the feeder in order to compensate for the perforation line being “out of square”, this may affect the accuracy of the crease. If this occurs adjust crease skew separately (see “Setting Crease Tilt Knob” section of this manual).
2. By adjusting the outfeed drive tires relative to the drive hubs it is possible to steer the sheet, (i.e. by placing the tire on top of the hub on one side of the paper only).



To set up rotary perforation a perforation blade and an opposing hardened anvil is necessary. This machine comes with a single perforation blade and an anvil. The perforation blades and anvils are split into two matching halves and are fitted to the drive wheels using the four screws supplied. Do not mix the matching pairs of blades or anvils as this will result in poor perforation.

 **CAUTION:**

*The circular blades are very sharp. Handle with care.*

## Setting up rotary perforation

1. Open the top cover.
2. Remove the rotary tool carrier.

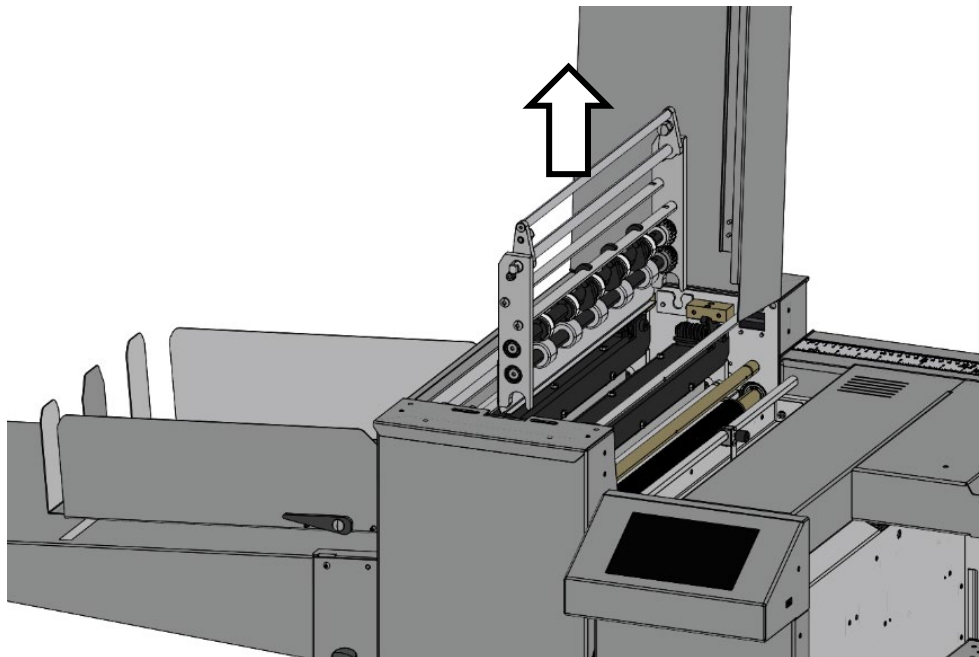

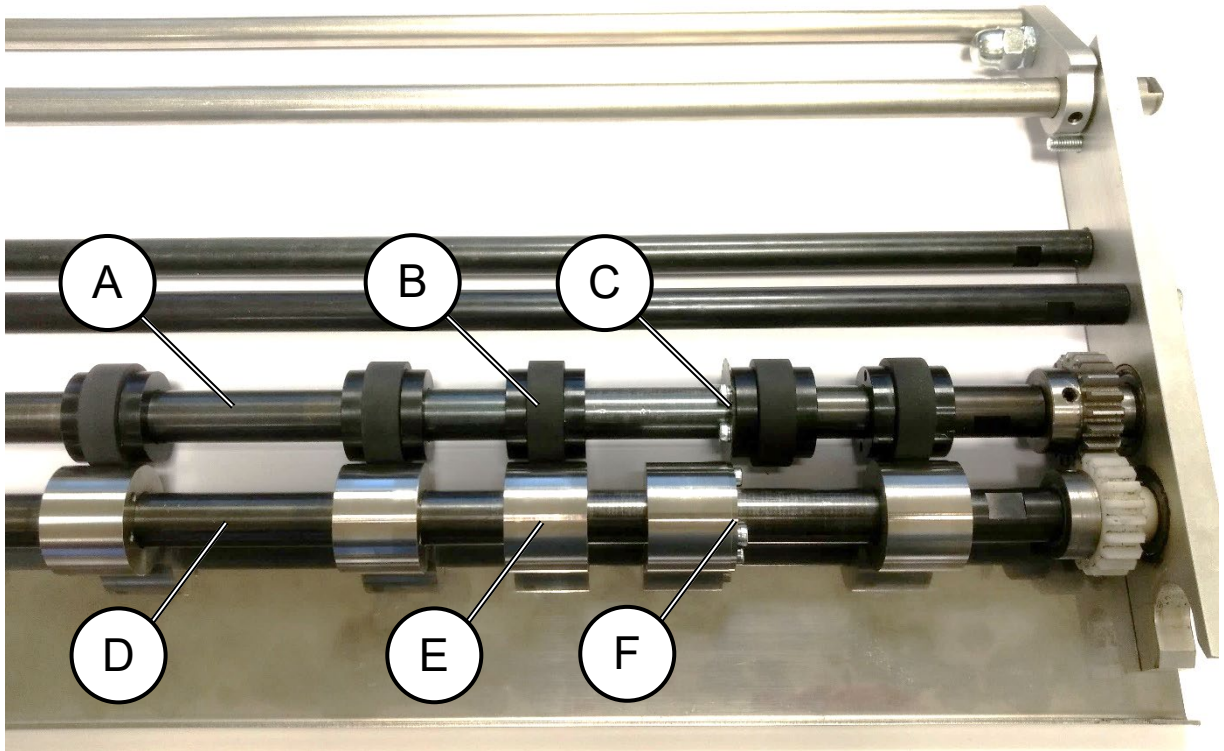

A – top shaft  
 B – drive wheel  
 C – perforation blade

D – bottom shaft  
 E – drive hub  
 F – anvil

 **NOTE:**

*Up to 5 rotary blades can be mounted on the rotary tool carrier.*

3. Using a 2 mm hex key loosen one of the drive wheels [B] and slide it away from any obstructing drive wheels or hubs in order to mount the blade.
4. Mount a matching pair of blades [C] and secure them to the drive wheel using a 2.5 mm hex key.

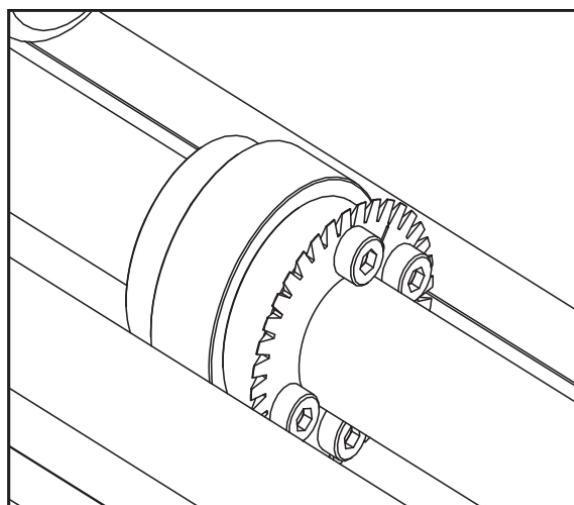

5. Using a 2 mm hex key loosen one of the drive hubs [E] and slide it away from any obstructing drive wheels or hubs in order to mount the anvil.

6. Mount a matching pair of anvils [F] and secure them to the drive wheel using a 2.5 mm hex key
7. Position the perforation blade [C] using the ruler on the rotary tool carrier. Secure the drive wheel in place using a 2 mm hex key.
8. Slide the drive hub with the anvil [F] towards the perforation blade until there is a small clearance ( $\sim 0.1$  mm / 0.004") and secure it in place using a 2 mm hex key.

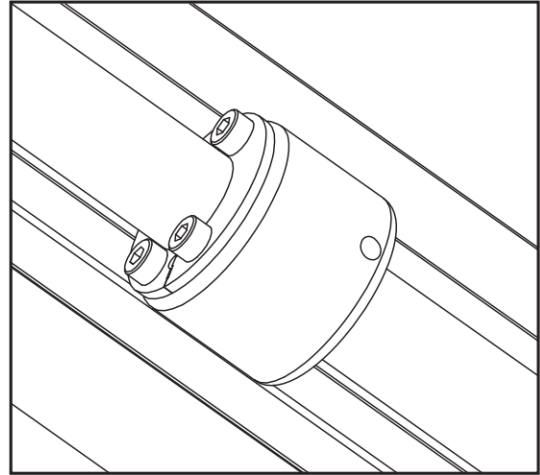

**NOTE:**

All drive wheel and drive hubs should be positioned on top of each other like items [B] and [E] in the previous page with the exception of the pair(s) on which the actual blade and anvil are mounted (items [C] and [F] in the previous page).

9. Slide one of the perforator strippers (in red) on top of the drive hub. This will help to remove perforated paper from the perforation blade to avoid entanglements. The other two perforator strippers can be positioned evenly on the shaft: their purpose is that of providing a top paper path surface.

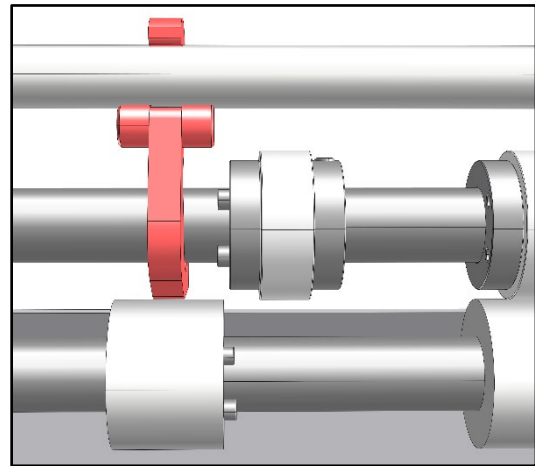

**NOTE:**

Use an 80 gsm sheet of paper to set the 0.1 mm (0.004") gap between the blade and the anvil. Do not force the blade against the anvil to prevent damage.

10. Place the rotary tool carrier back in the machine and close the top cover.
11. Run a proof sheet and inspect the output.

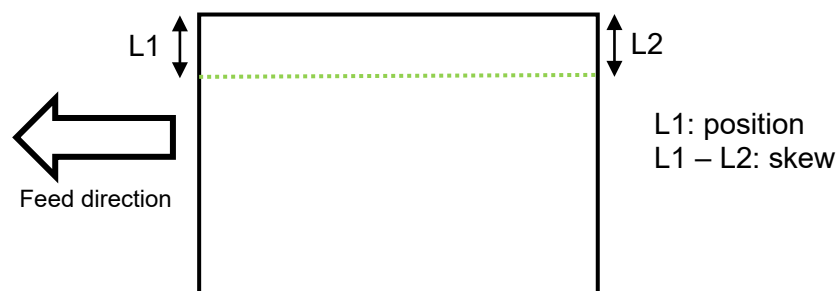

12. If position adjustment is necessary, repeat steps 8 to 11.
13. If the perforation is skew on the sheet ( $L1 \neq L2$ ) use the feeder skew adjustment to correct for this (steps 14 to 18 on the next page).



**NOTE:**

Changing feeder skew also affects the crease. See "Setting Crease Tilt Knob" section of this manual to adjust this.

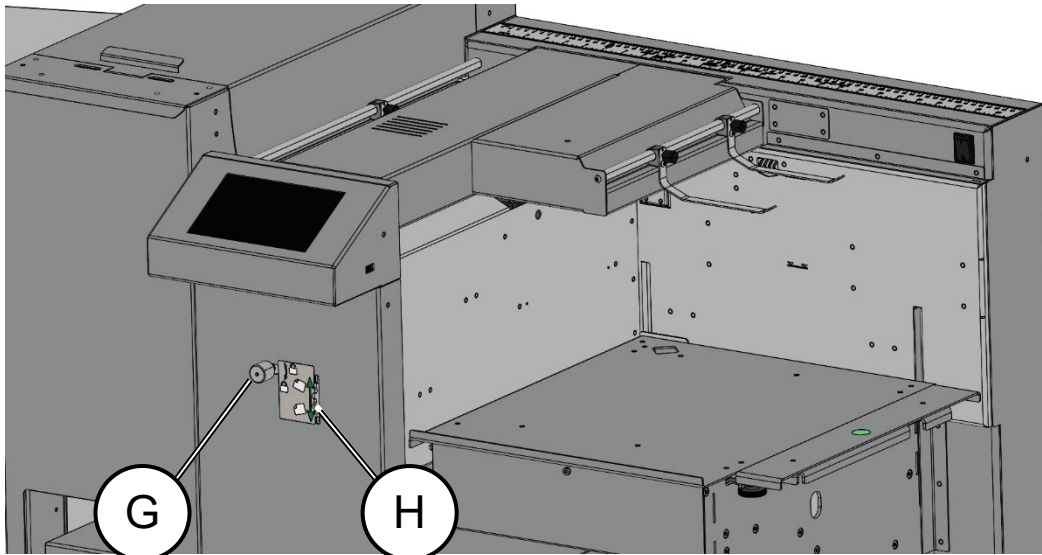

14. Loosen locking knob G by rotating it counterclockwise.
15. Use the adjustment wheel H to set paper registration wall angle. If the sheet skews inboard away from the operator ( $L1 > L2$ ) turn the wheel down. If the sheet skews outboard towards the operator ( $L1 < L2$ ) turn the wheel up.
16. Lock the adjustment by rotating knob G clockwise.
17. Set the sheets on the paper table in the corner and adjust magnetic paper guides if necessary.
18. Run a proof sheet and inspect the output. If further adjustment is necessary, repeat steps 14 to 18.

 **NOTE:**

*When not in use:*

1. *the rotary perforation can be disengaged by sliding either the blade or the anvil to one side so that there is at least a 5 mm (0.2") gap between them. However, it is recommended to remove the blades and anvils completely to avoid unwanted marking on delicate media;*
2. *Distribute the perforation strippers (in red) evenly on the shaft (as shown below);*
3. *All drive wheels and drive hubs should be positioned on top of each other as per picture below. This is how this assembly is supplied from the factory.*

*For optional perforation blades see "Optional Parts" in this manual.*

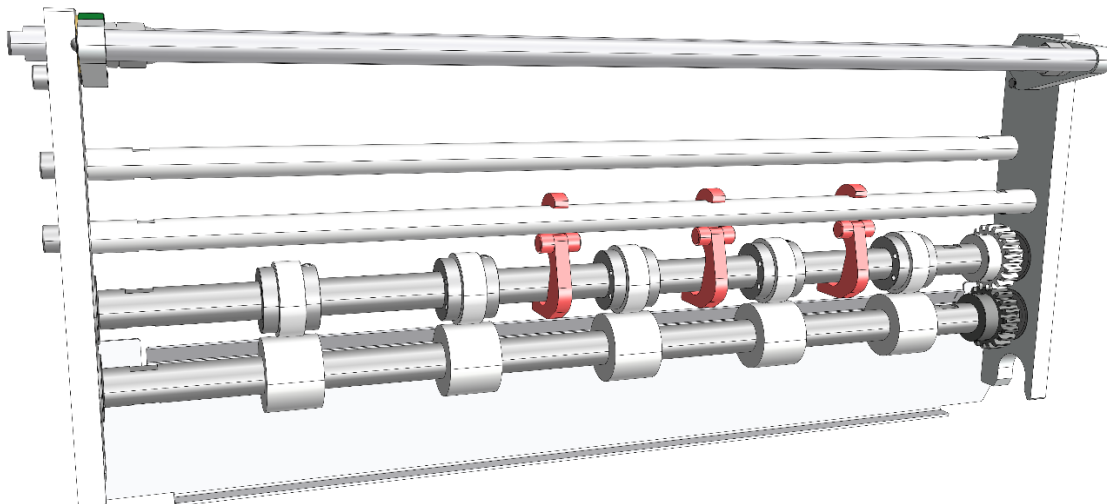

# Cross Perforation

## Blade removal / replacement

**⚠ WARNING!**

All blades are very sharp: use extreme caution when handling the blades.

1. Locate the Allen tools supplied with the Cross Perforation kit.
2. Place the cross perforation tool on a table in the orientation shown below.
3. Remove one guide bolt [C] and spring [D]. Only one side needs to be removed.

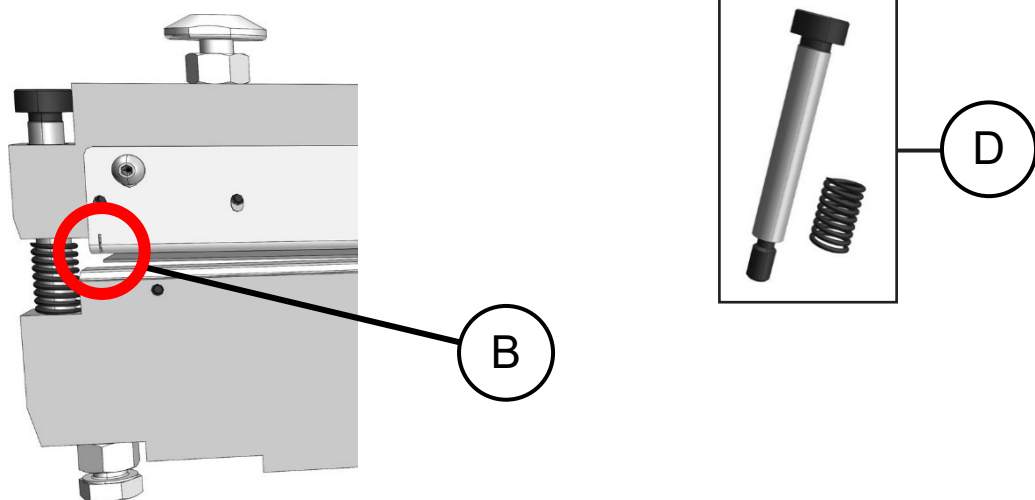
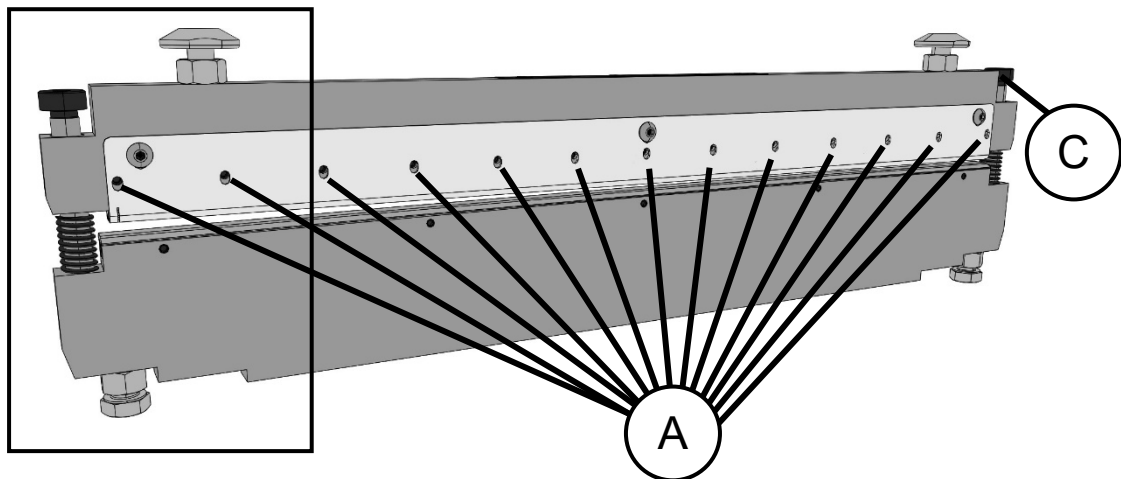

4. Rotate the bottom assembly 180° from the top assembly as shown below.

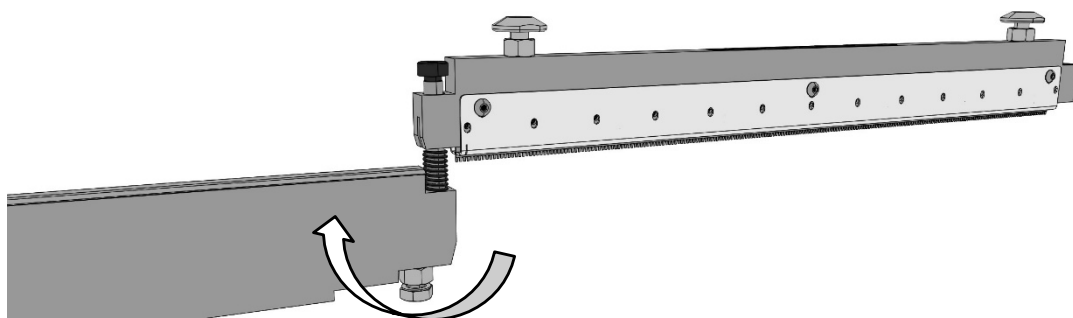

Continued on next page...

**⚠ WARNING!**

All blades are very sharp: use extreme caution when handling the blades.

- 5. Loosen grub screws [A] (x13). *Shown on previous page.*
- 6. Lift out the Blade [E].

1

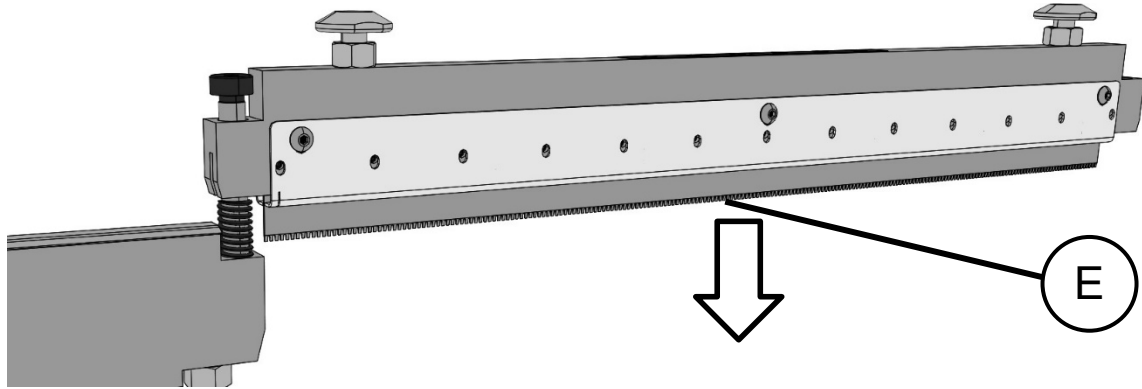

- 7. Replace with required blade.

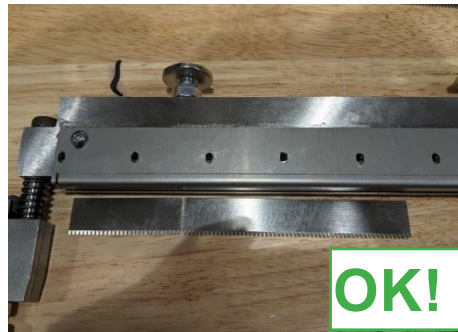
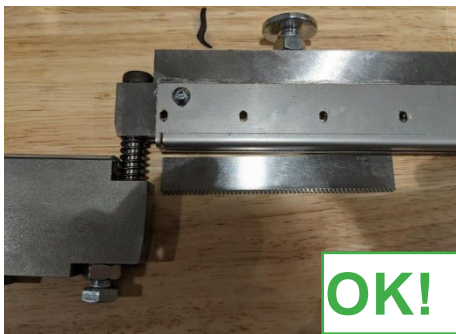

Double stacking is NOT supported.

Continued on next page...

**⚠ WARNING!**

All blades are very sharp: use extreme caution when handling the blades.

8. Insert the blade into the blade channel.
9. Ensure the blade is fully inserted and does not exceed the notch [B]. *Shown on previous page.*

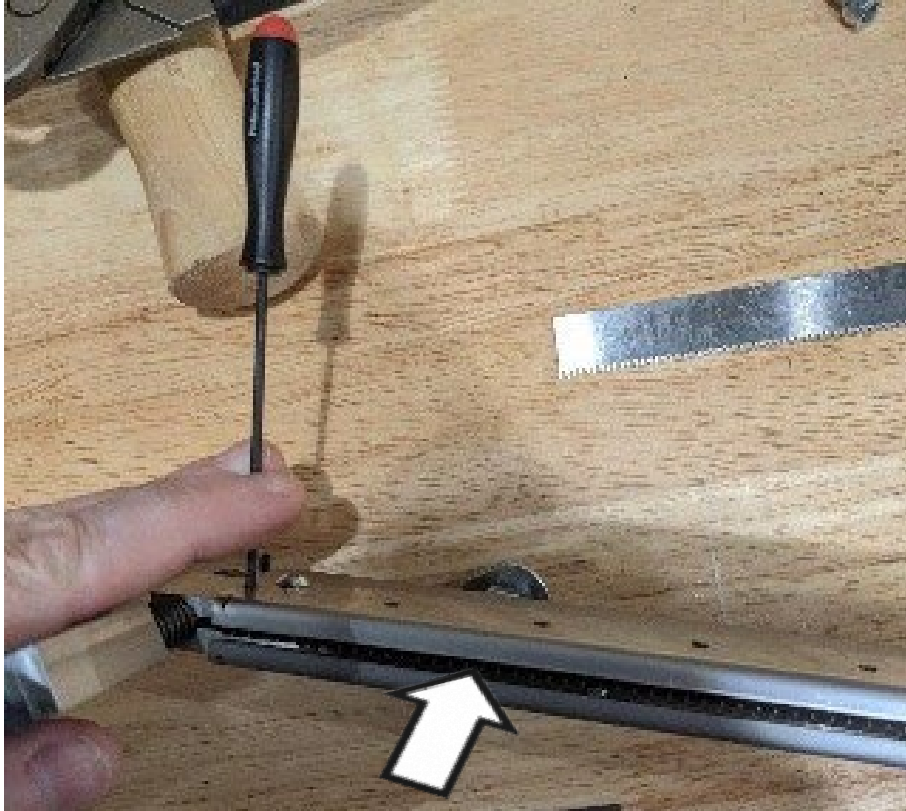

10. Tighten grub screws [A] (x13).
11. Rotate the bottom assembly 180° back into line with the top assembly.
12. Replace bolt [C] and spring [D] and tighten.

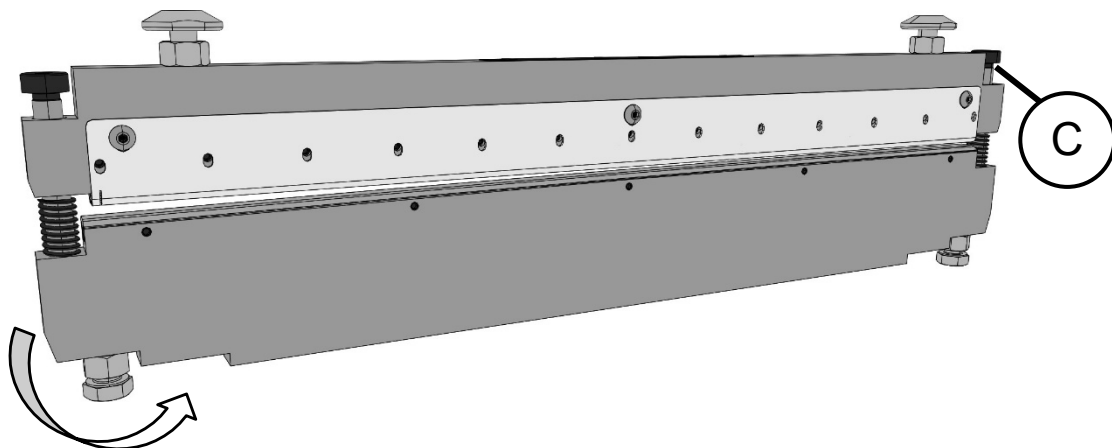

---

## Anvil strip removal / replacement

---

**⚠ WARNING!**

All blades are **very sharp**: use extreme caution when handling the blades.

**📌 NOTE:**

Before replacing anvil strip, decrease perforation depth to avoid causing excess strain on motor and reducing life span of anvil strip. Adjustment procedure can be found under 'perforation depth adjustment'.

1

1. Locate the Allen tools supplied with the Cross Perforation kit.
2. Place the cross perforation tool on a table in the orientation shown below.
3. Remove one guide bolt [C] and spring [D]. Only one side needs to be removed.

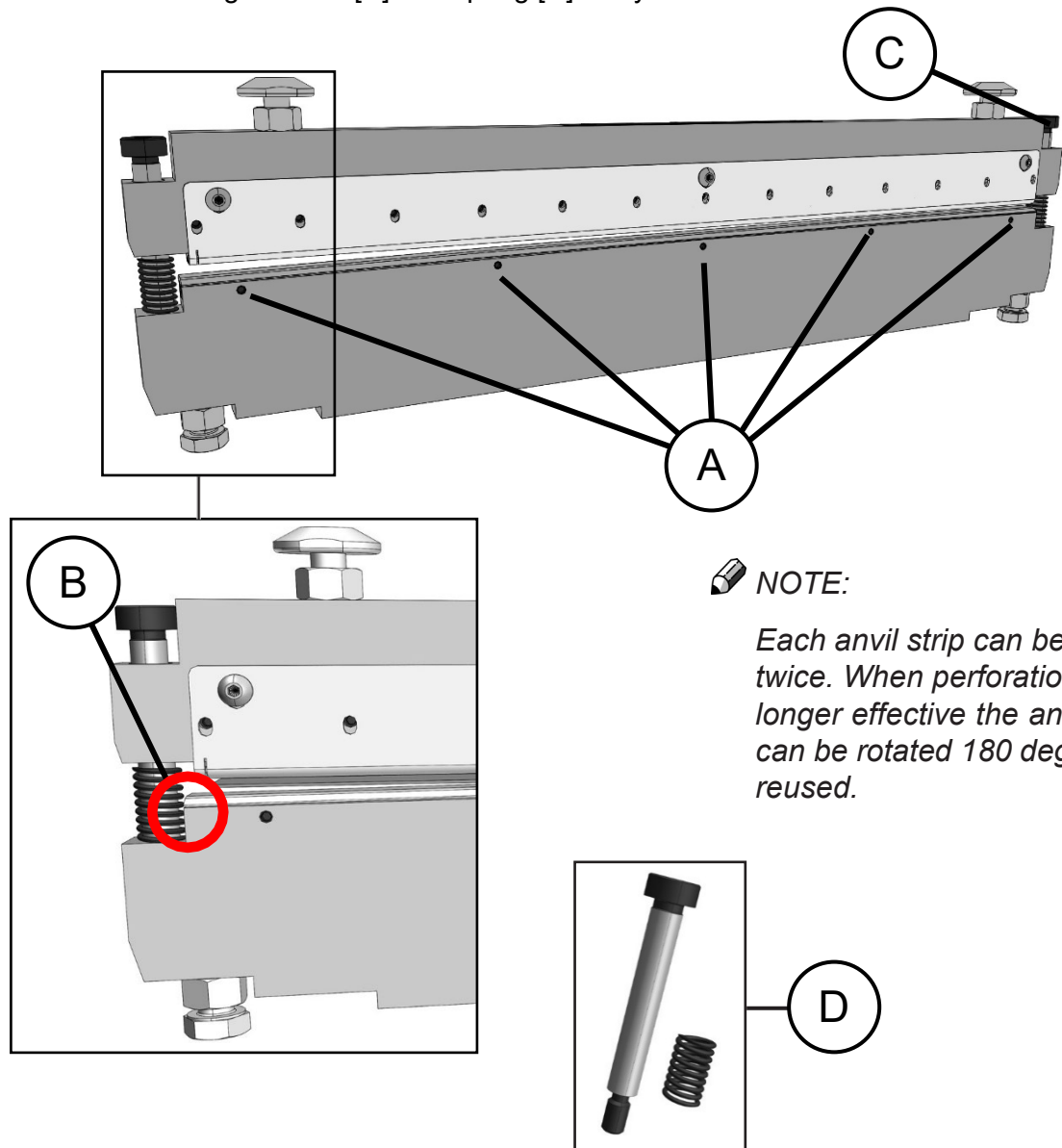

**📌 NOTE:**

Each anvil strip can be used twice. When perforation is no longer effective the anvil strip can be rotated 180 degrees to be reused.

Continued on next page...

**⚠ WARNING!**

All blades are very sharp: use extreme caution when handling the blades.

4. Rotate the bottom assembly 180° from the top assembly as shown below.

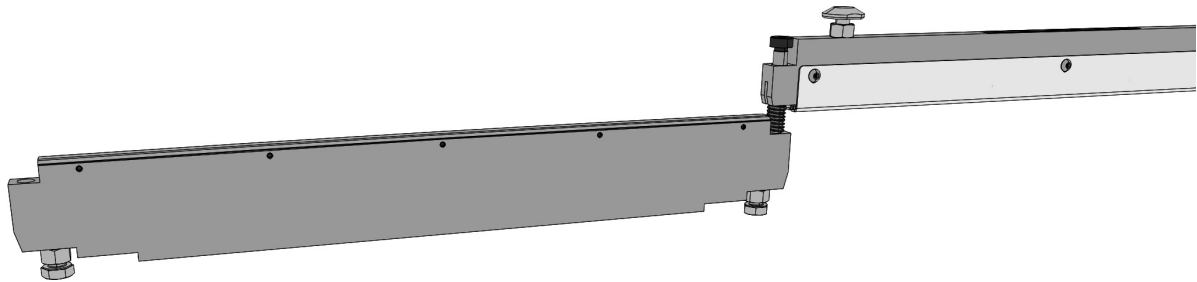

1

5. Loosen grub screws [A] (x5). *Shown on previous page.*
6. Lift out the anvil strip [E].
7. Rotate anvil strip 180° or replace with spare.

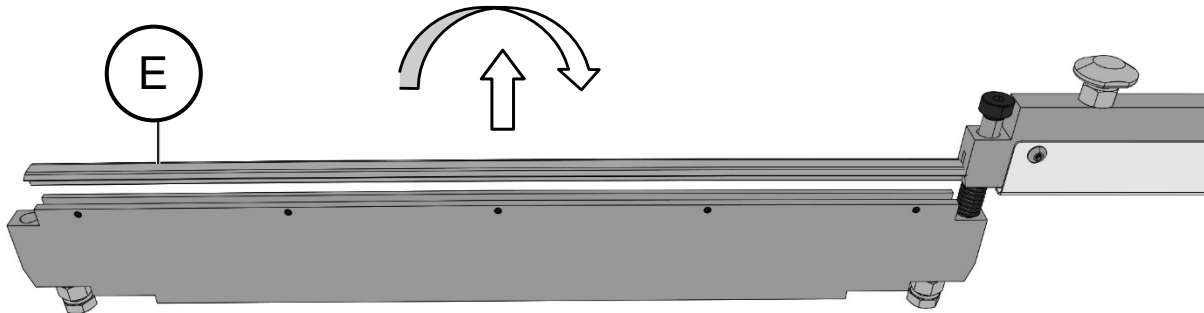

8. Insert the anvil strip into the anvil channel.
9. Ensure the anvil strip is fully inserted and aligned with the edge of the anvil [B]. *Shown on previous page.*
10. Tighten grub screws [A] (x5).
11. Rotate the bottom assembly 180° back into line with the top assembly.
12. Replace bolt [C] and spring [D] and tighten.

---

## Perforation depth adjustment procedure

---

**⚠ WARNING!**

All blades are very sharp: use extreme caution when handling the blades.

**📝 NOTE:**

Before adjusting depth of perforation ensure the anvil strip does not require replacement.

1

1. Locate the tools supplied with the Cross Perforation kit.
2. Place the cross perforation tool on a table in the orientation shown below.
3. Adjust [A] (bolt [B] & nut [C]) to increase or decrease depth of perforation.

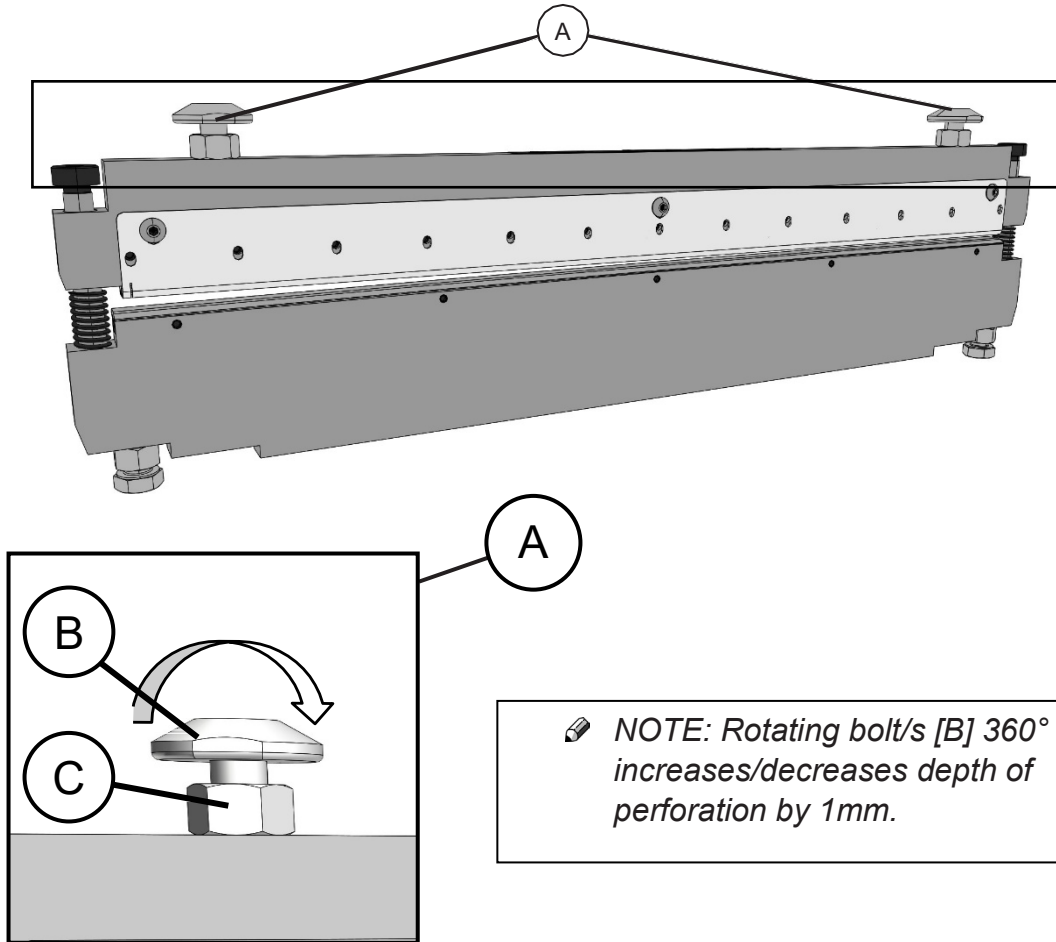

4. Turn nut(s) [C] anti-clockwise to unlock.
5. Rotate bolt(s) [B] 90° anti-clockwise to increase perforation depth or rotate bolt(s) [B] 90° clockwise to decrease perforation depth.
6. Hold bolt(s) [B] in position and turn nut(s) [C] clockwise to lock.

# 2 Setting Up a Job

## Getting Started

### Turning the Machine On and Off

2

1. Ensure the main power cord is plugged in the machine [A] and the wall socket.

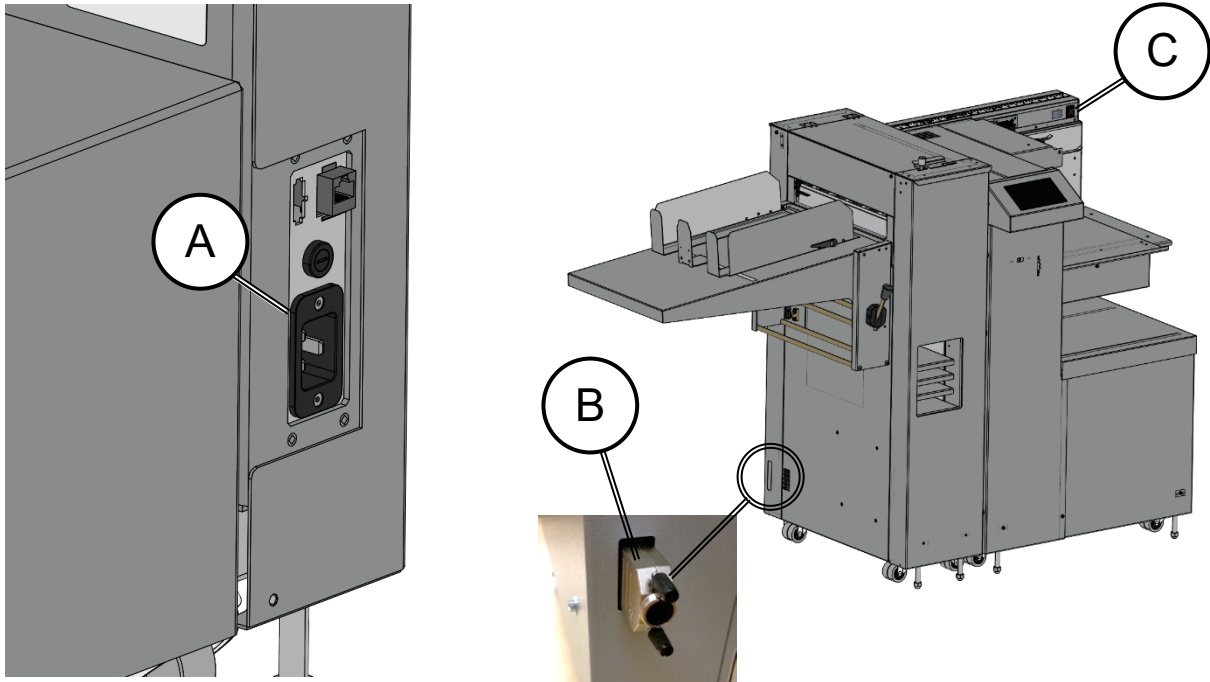

2. Ensure the CAN termination plug [B] is plugged in.
3. Toggle the main power switch [C] to turn the machine on.
4. To turn the machine off again toggle the main power switch [C] again.

 **NOTE:**

*If the CAN termination plug is not plugged in the machine may not function correctly.*

---

---

## Paper Stack Preparation

---

Before loading paper in this machine, it is recommended to fan the sheets as shown.

1. Hold the paper stack on a flat surface.



2. Bend the paper stack.



3. Use your fingers and thumbs to pinch the paper stack.

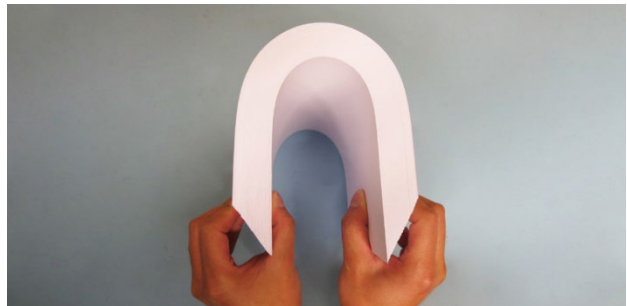

4. With the paper pinched between your fingers, straighten out the paper stack.



- 
- Flex the paper back and forth a couple of times to break surface tension and pre-separate the sheets.



2

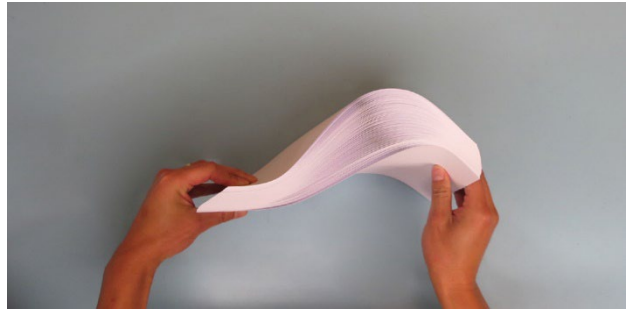

- Realign the sheets into a stack before putting them in the machine.

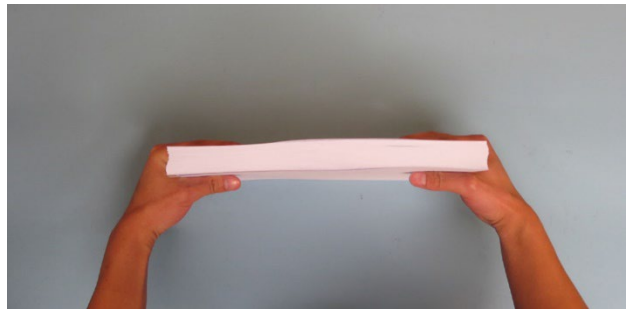

 **NOTE:**

*If the sheets you are using are too stiff or too large format to carry out the above procedure, fan the front edge of the sheets when loading them in the machine.*

---

## Loading Paper

---

2

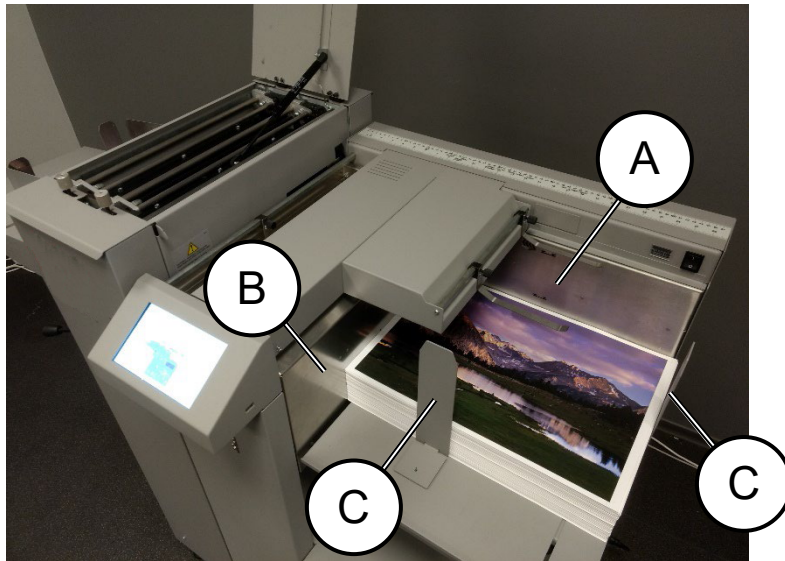

1. Take a stack of printed paper and place it on the feeder table in the desired orientation.

 **NOTE:**

*If using sheets longer than 450 mm (17.7"), but shorter than 700 mm (27.6") extend the built-in pull-out table. If using sheets longer than 700 mm (27.6") see the "Feeder Table Extension" section within this manual.*

2. Ensure the paper is pushed into the corner and is aligned to both the registration wall [A] and the front wall [B].
3. Align the magnetic paper guides [C] with the edges of the paper stack. Ensure the guides are not too tight and the sheets can move freely.

 **NOTE:**

*To make sure the magnetic paper guides are not too tight put a single sheet of paper between the stack and the guide when setting the guide.*

4. Take a single sheet from the stack and use it to set the magnetic stacker guides to this paper size. Use the lever [D] to raise the stacker guides from the surface to make them easier to move.

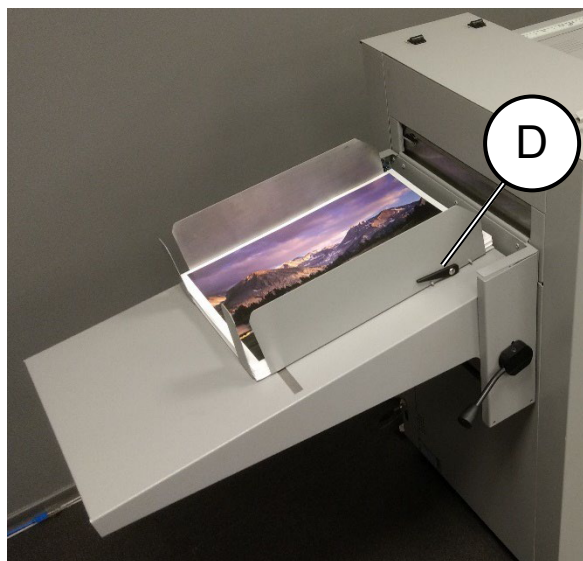

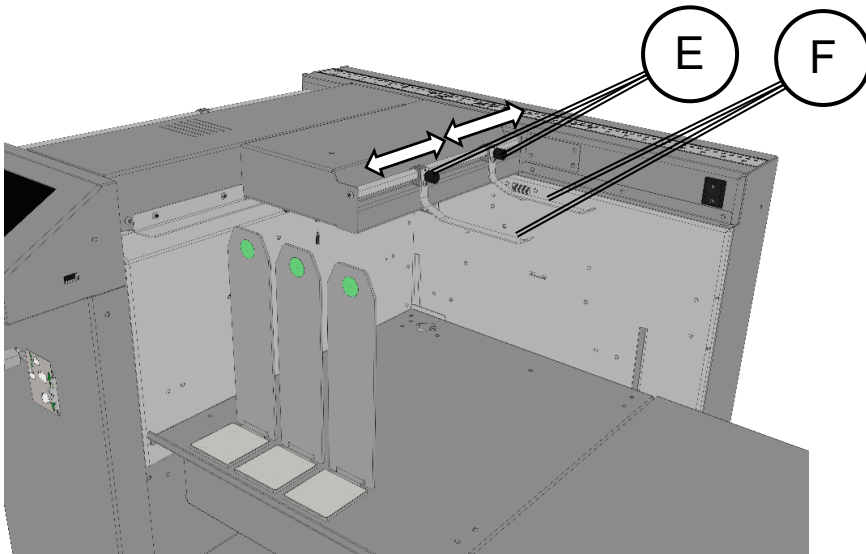

- 5. Loosen the knobs [E] (x2) to move paper guide tongues [F] (x2) according to the width of the loaded paper.
- 6. Tighten the knobs [E] (x2).

If stacking paper narrower than 256 mm / 10.07" use front paper guide to support narrow sheets. This paper guide attaches to Separation frame by magnets.

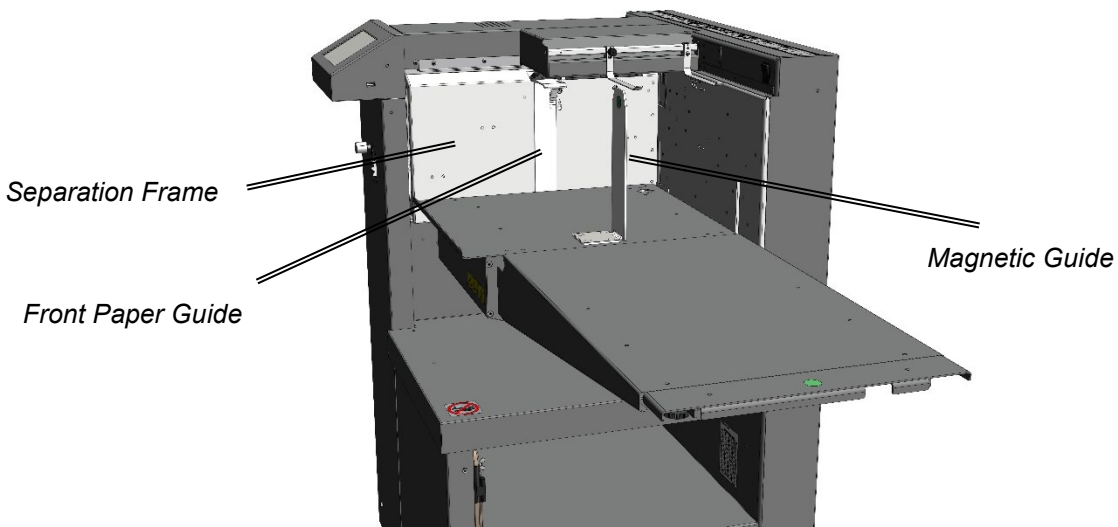

### How To Use Paper Guide Front



- 1. Place the paper guide on the front wall.

2



2. Align with front edge of the paper pile.



3. Push up against vacuum belts



4. Ensure the guide is parallel to the pile.

---

## Feeder Table Extension

---

Install table extension if using sheets longer than 700 mm (27.6"):

1. Ensure the built-in pull-out table [A] is fully stowed.

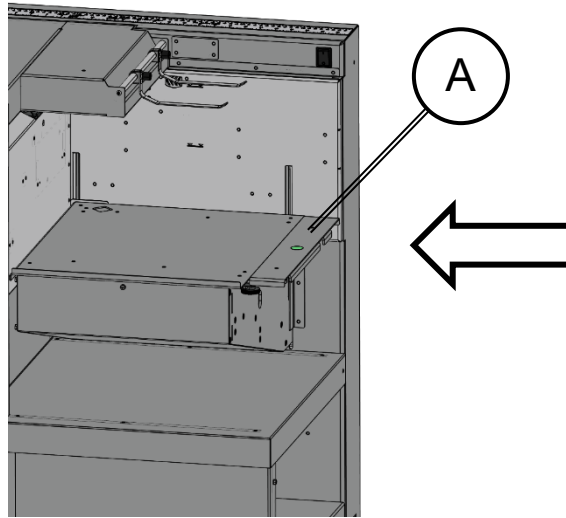

2. Hook the table extension [B] into the lift [C] as shown.

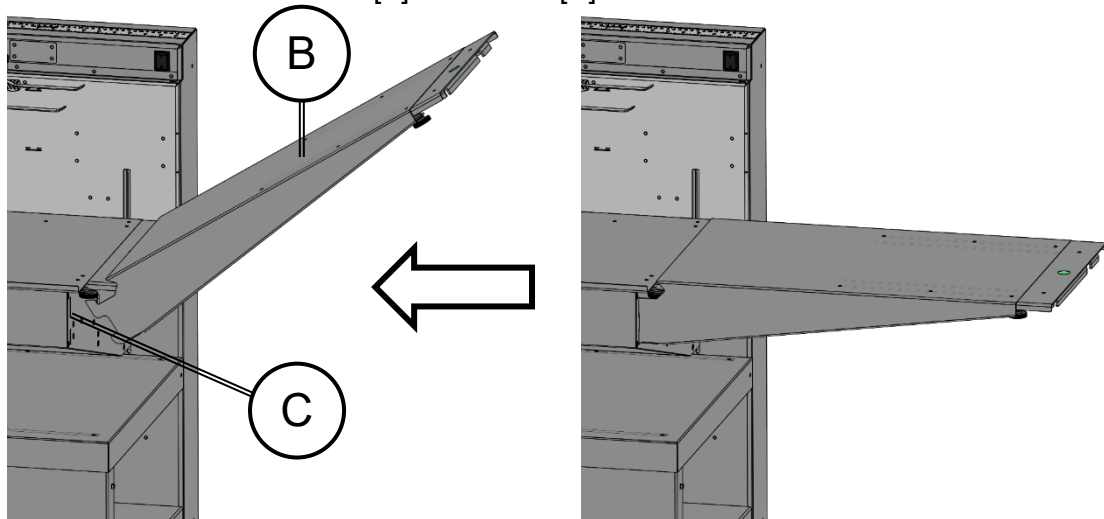

 **NOTE:**

The feeder table extension has a built-in pull out part that can be used to feed sheets up to 1300 mm (51").

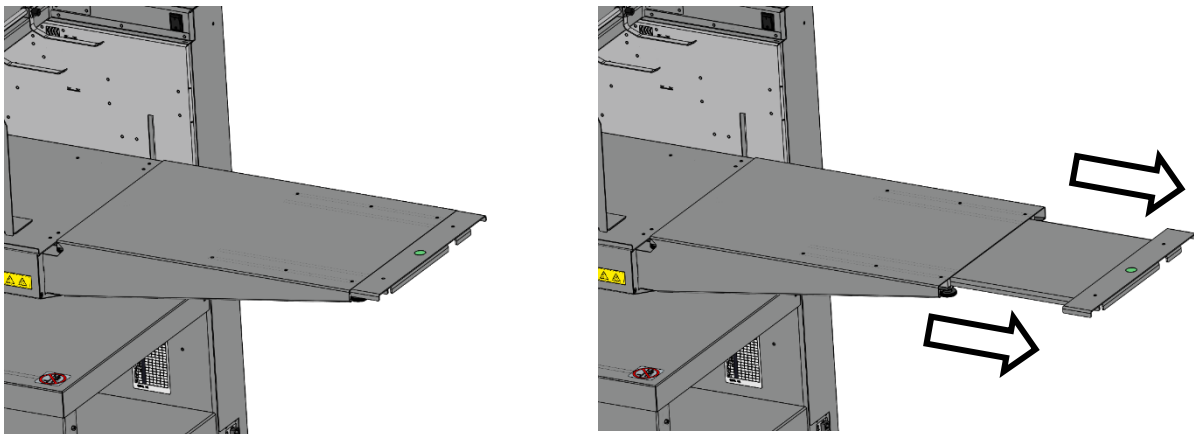

# The Home Screen

## Overview

2

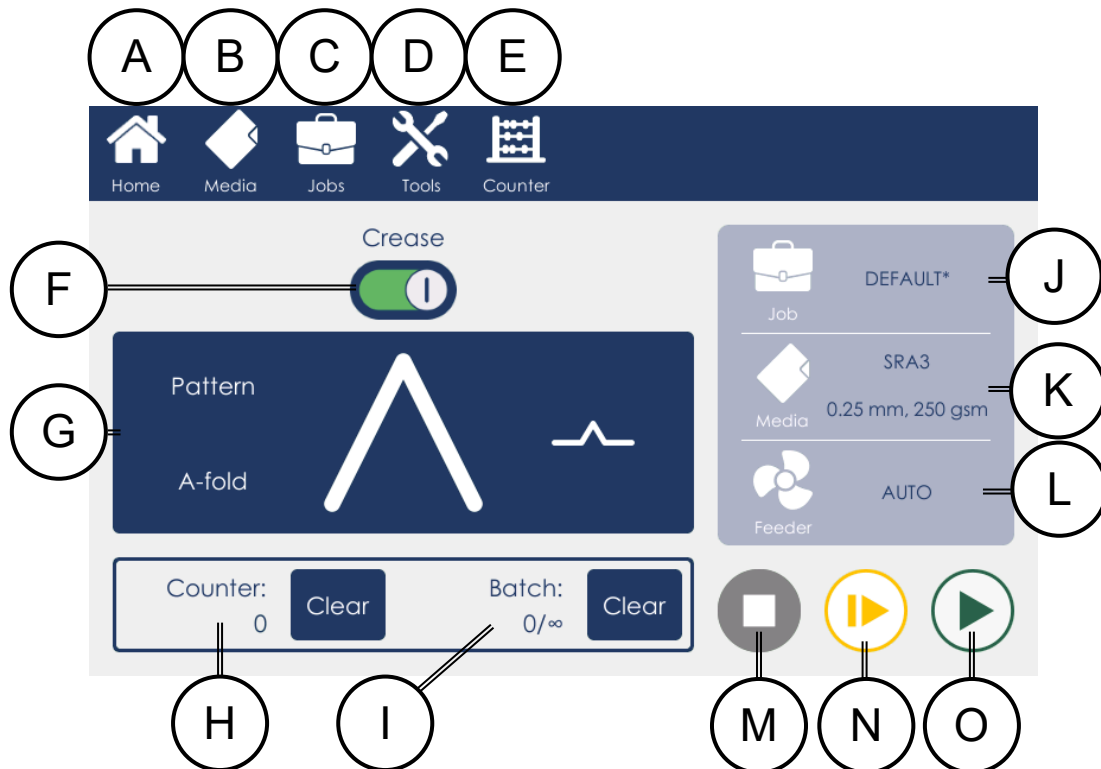

Element		Description
A	Home button	Returns to this screen
B	Media button	Set paper size and thickness for this job
C	Jobs button	Save / load job
D	Tools button	Access additional machine settings
E	Counter button	Set batch counter behavior
F	Crease switch	Switch creasing on or off
G	Pattern button	Choose a pre-set or custom crease pattern
H	Total counter	Displays the number of sheets processed since it was last cleared. "Clear" button resets it back to zero.
I	Batch counter	Displays the number of sheets processed in this batch and the batch size. "Clear" button resets it back to zero.
J	Job name	Displays current job name. Asterisk (*) indicates that job parameters have changed since the job was last saved.
K	Media type	Displays currently selected paper size and thickness
L	Feeder settings	Displays feeder operation mode – AUTO or Custom
M	Stop button	Stops the machine cycle
N	Proof / Pause button	Processes a single proof sheet with the current settings. If the machine is running, pauses the cycle.
O	Play button	Starts the machine cycle with the current settings.

## Paper Size

To set paper size and type:

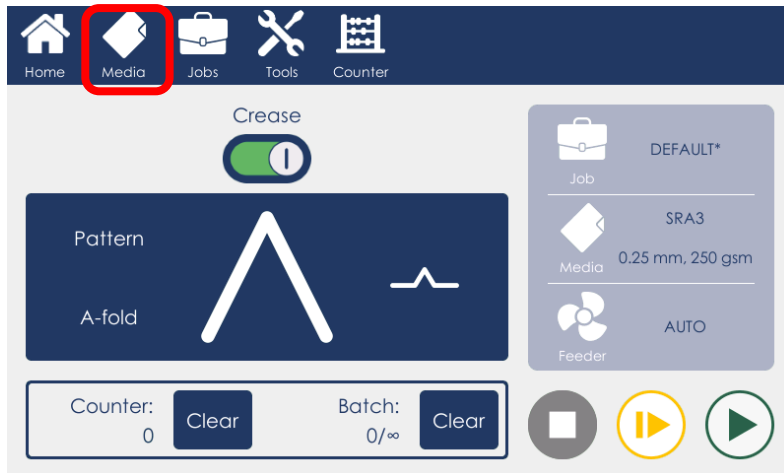

1. Choose Media from the top menu in the Home screen

**NOTE:**  
Changing paper size or thickness will reset any fine adjustments that may have been entered on other screens.

2

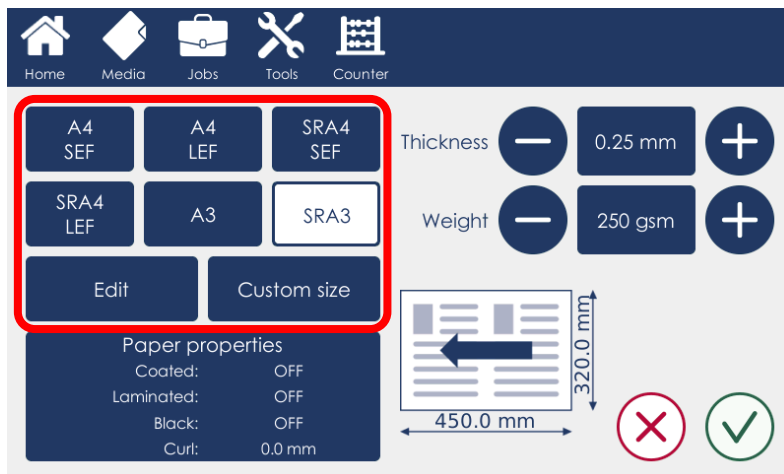

2. Select one of the pre-defined paper sizes. To enter a custom size click Edit

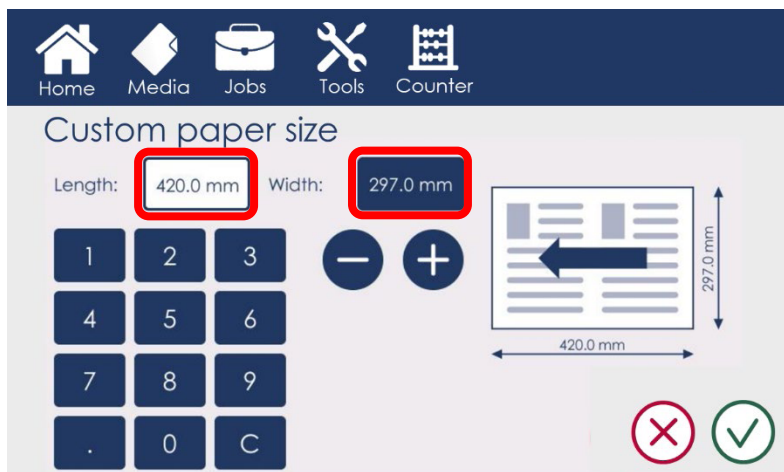

- 2.1. Click on Length and Width to enter the desired custom size. Click the green tick mark to confirm.

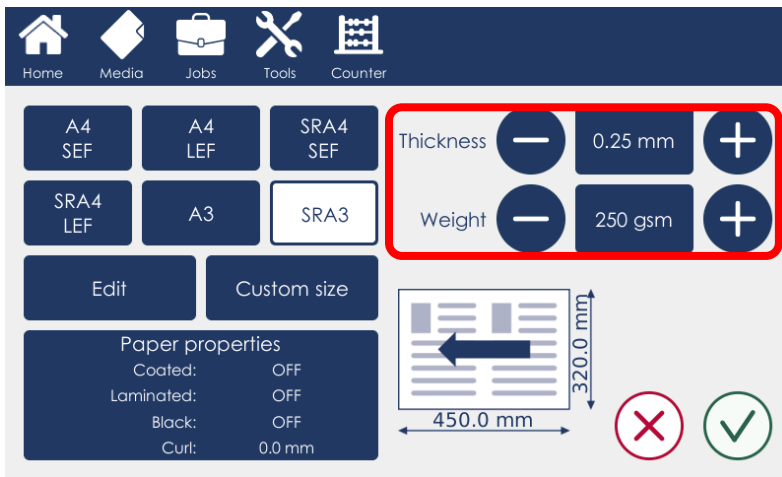

3. Set paper thickness and paper weight

**NOTE:**  
Measure paper thickness using the included vernier caliper.

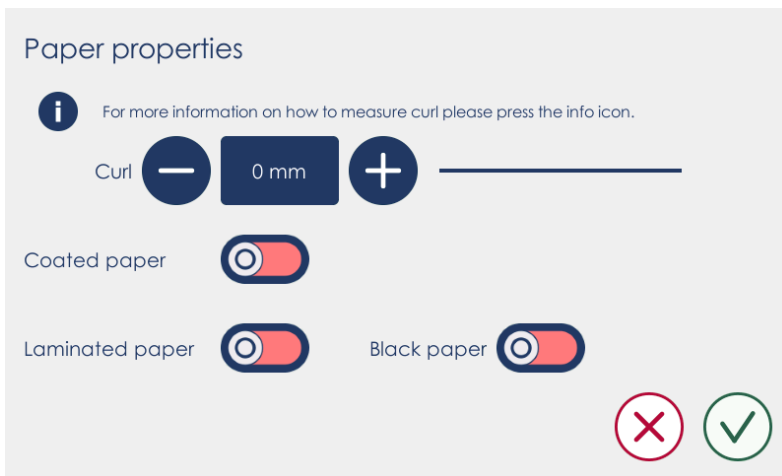

4. Advanced: Enter paper surface finish and curl if necessary.

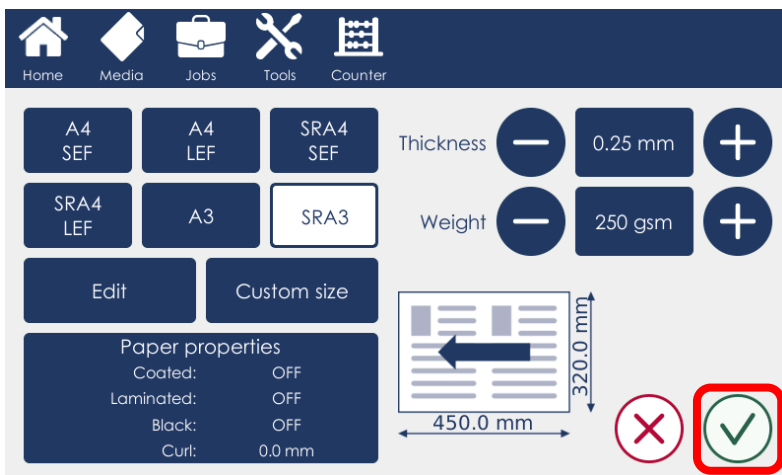

5. Confirm the settings by clicking the green tick mark.

## Pre-set Patterns

To set up one of the pre-defined creasing patterns:

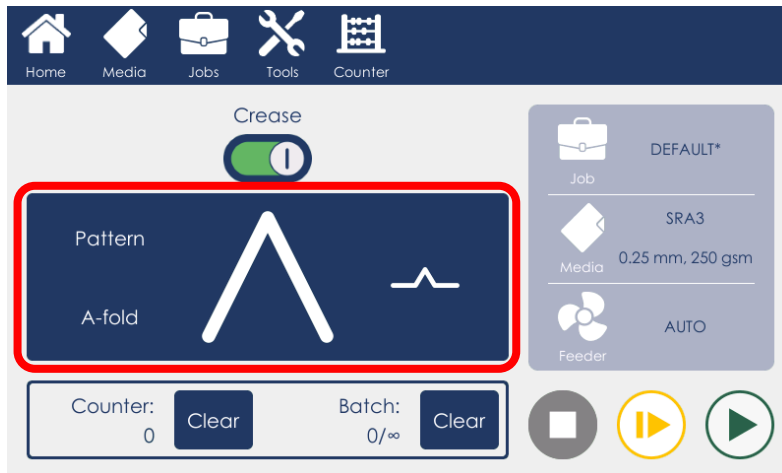





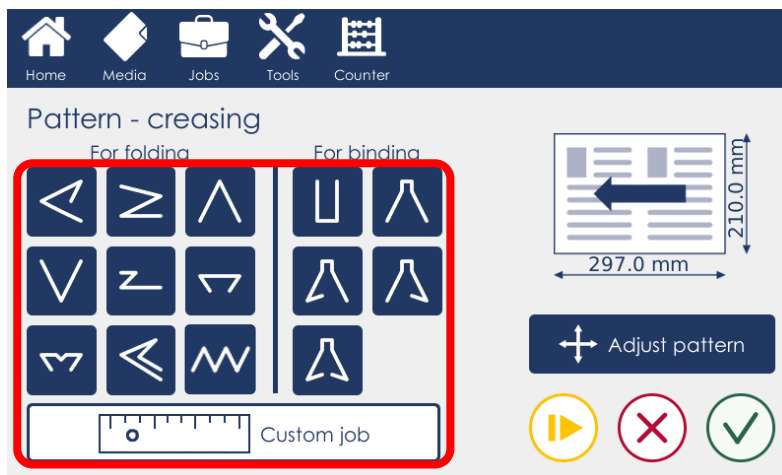



1. Click the Pattern button on the Home screen





**NOTE:**  
Choosing a new pre-set pattern will reset any fine adjustments that may have been entered on other screens.



2. Select one of the pre-defined creasing patterns. The left column contains patterns for typical folded jobs. The right column contains patterns for book covers.

**NOTE:**  
You can also choose Custom job to set up your own pattern. See "Custom Job" section of this manual for details.

-  Letter fold (tri-fold)
-  Concertina fold (Z fold)
-  Half fold A
-  Half fold V
-  Engineering fold
-  Gate fold
-  Closed gate fold
-  Double parallel fold
-  Equally spaced creases

-  Spine crease
-  Hinge crease
-  Hinge crease with front flap
-  Hinge crease with rear flap
-  Hinge crease with two flaps

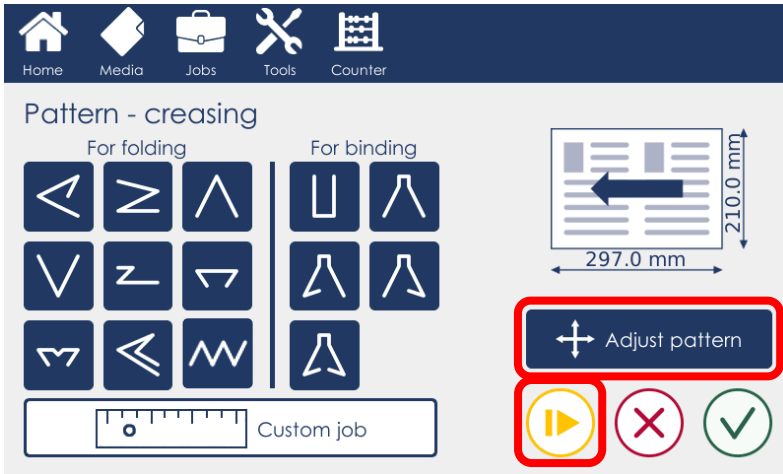

- Click the Proof button to run a single sheet. Inspect the output:
  - If the job is as desired click the green tick mark to confirm the job and return to the Home screen.
  - If the job requires adjustment click the Adjust pattern button

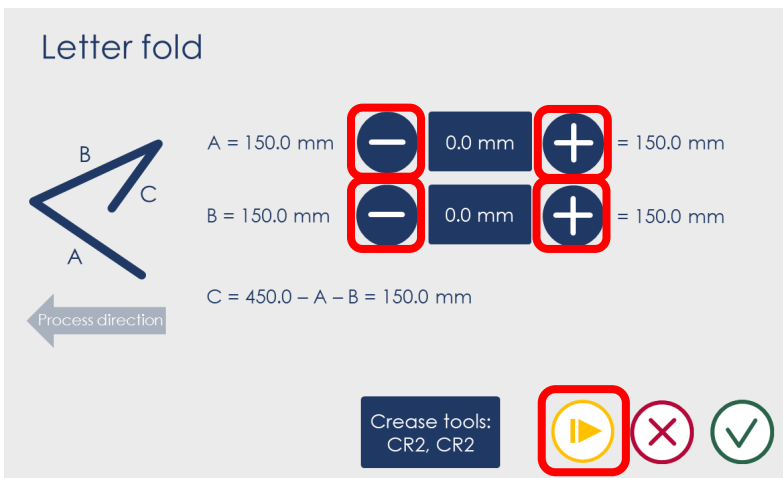

- Each pattern has an adjustment screen that allows making small corrections to crease positions to achieve the desired output. Use the + / - buttons to make the adjustment and press the Proof button to run another proof sheet. When satisfied click the green tick mark.

**NOTE:**  
 You can also choose which crease tool to use by clicking the Crease tools button.

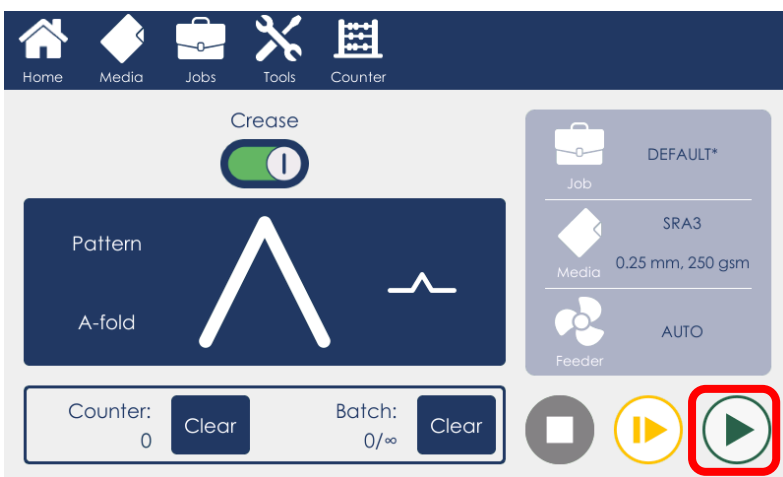

- On the Home screen click the Play button to start the machine cycle.

## Custom Job

To fully customize the number and position of creases on the sheet set up a custom job:

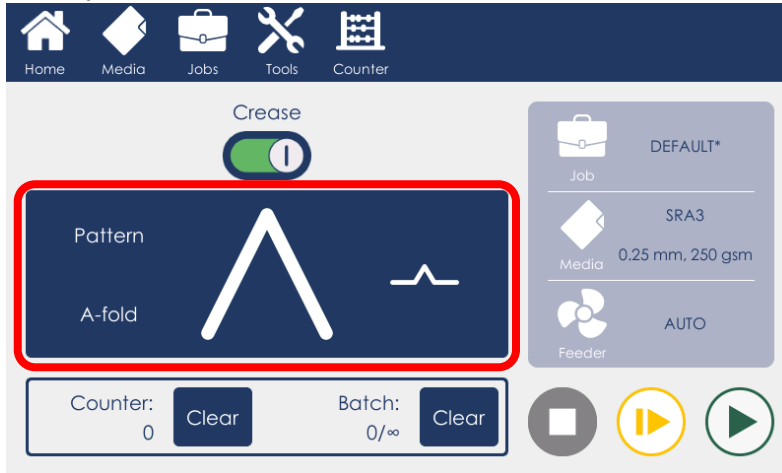

1. Click the Pattern button on the Home screen

**NOTE:**  
Choosing a new pattern will reset any fine adjustments that may have been entered on other screens.

2

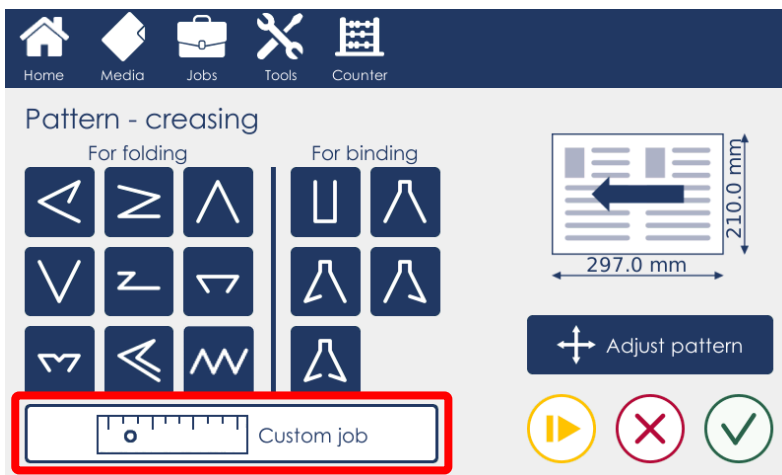

2. Select Custom job.

**NOTE:**  
The custom job will be based on the previously selected pre-set.

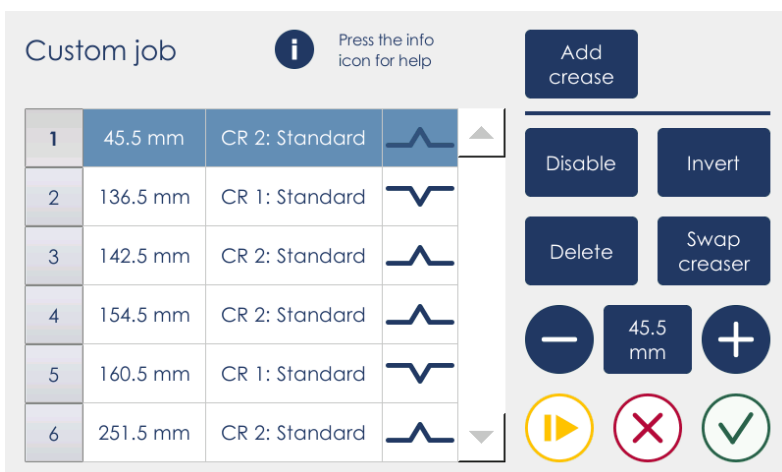

3. Custom job screen:

- Click Add crease to add more creases to the list.
  - Select a crease and use the + / - buttons to adjust its position.
  - Use the Delete button to remove the selected crease from the list.
  - The Swap creaser button can be used to select whether the 1<sup>st</sup> or the 2<sup>nd</sup> creaser will be used to make this crease (only available if the optional creaser unit has been installed).
  - Use the Proof button to test run a single sheet.
  - When satisfied, click the green tick mark.
- Use the Disable button to temporarily suspend the selected crease without deleting it (for example, when programming jobs in two passes)
  - The Invert button disables all currently enabled creases and enables all currently disabled creases. Use this when running jobs in two passes.

## Saving and Loading Jobs

To store a customized job or to load a previously saved job:

2

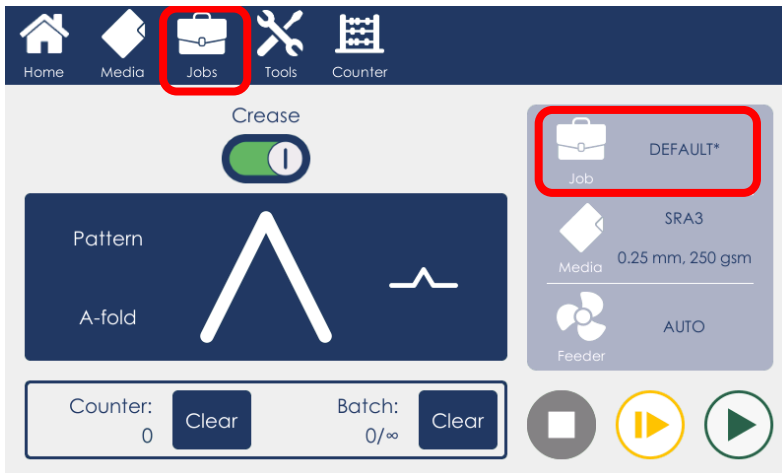

1. Choose Jobs from the top menu on the Home screen



**NOTE:**

The current job name is displayed in the box on the right. Asterisk (\*) following the job name indicates that there are unsaved changes to this job.

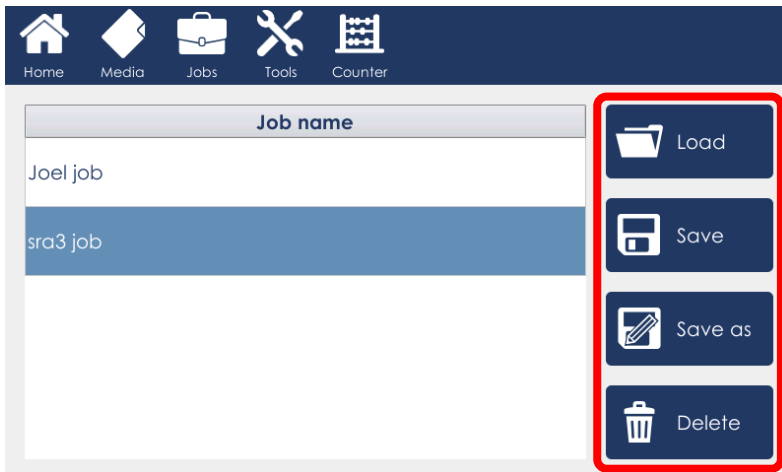

2. To save the current settings, click Save or Save as.

To load a previously saved job, click Load.

Load – loads the currently selected job.  
Save – saves the current job  
Save as – saves the current job under a new name  
Delete – erases the currently selected job.



**NOTE:**

Loading a job will overwrite the current settings.

## Counters

Once the machine cycle is started by default this machine will continue processing sheets until there is no more paper on the table. Alternatively, the machine can be configured to run in batch mode:

- Stop mode – the machine will stop after the specified number of sheets has been processed. If another cycle is started by the operator another batch with the specified number of sheets will be processed.
- Pause mode – the machine will pause for a short time after the specified number of sheets has been processed and start processing another batch automatically.

### NOTE:

*It is convenient to set up batch mode with a short pause to let the operator work in tandem with the machine. While the machine is paused the operator can remove the finished sheets from the stacker and pack or process them further while the machine produces the next batch.*

To set up batch mode:

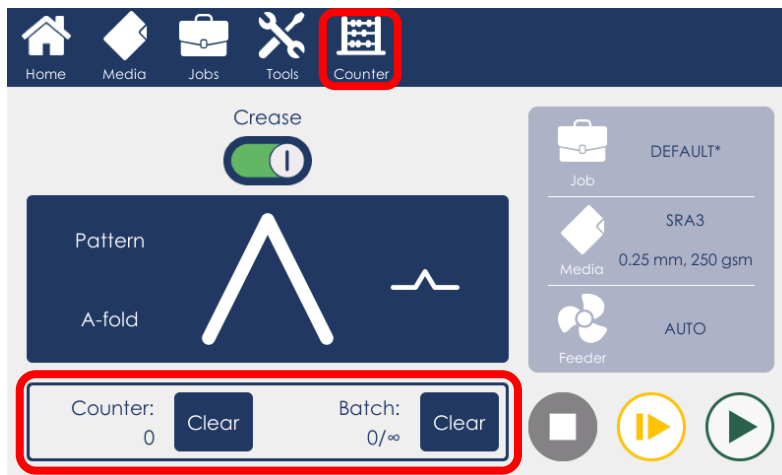

1. Choose Counter from the top menu on the Home screen

### NOTE:

*Current total and batch counters are displayed at the bottom of the Home screen. They can be reset at any time by clicking the Clear buttons.*

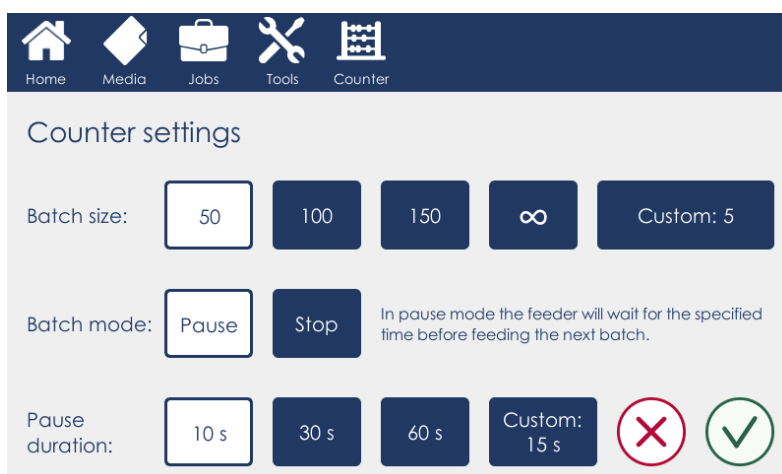

2. Select the desired batch size. Selecting the infinity symbol ( $\infty$ ) switches off batching.
3. Selected batch mode – Pause or Stop.
  - 3.1. For pause mode specify the desired pause duration between batches.
4. Click the green tick mark to confirm your selection and return to the Home screen.

# The Tools Screen

## Overview

The Tools screen allows the operator to adjust advanced machine settings. To access the Tools screen:

2

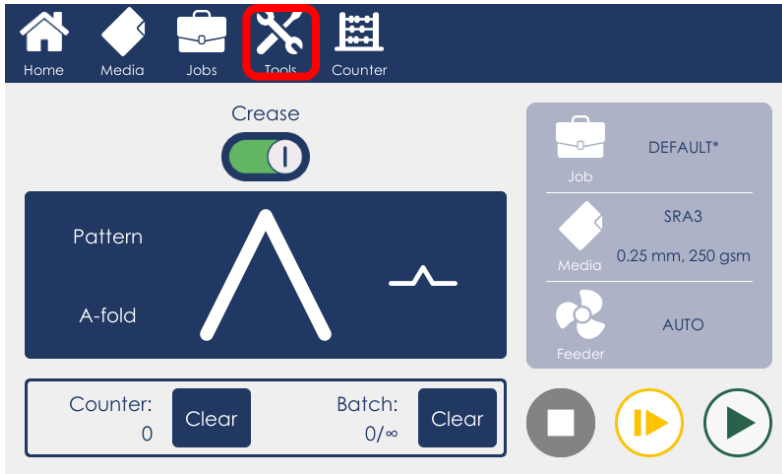

1. Choose Tools from the top menu on the Home screen

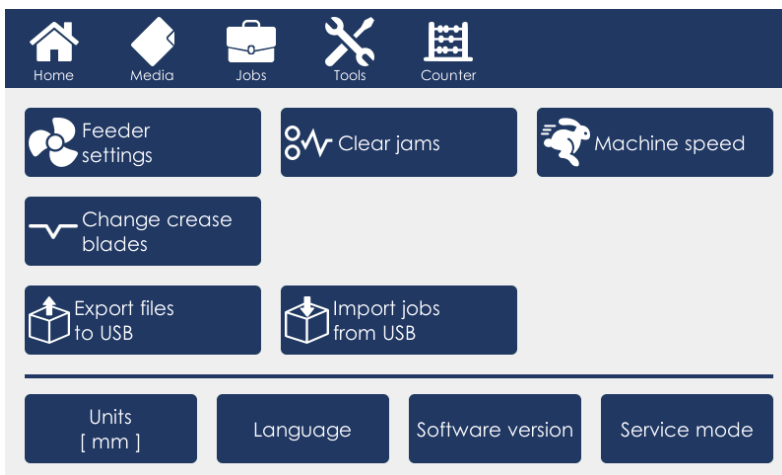

2. Select the desired function.

Element	Description
Feeder settings	Allows the adjustment of feeder fan, lift and sensor settings in case the automatic settings do not provide satisfactory feeding performance.
Clear jams	Jog machine rollers and creasing tools to dislodge any jammed paper.
Machine speed	Adjust machine operations speed for processing especially sensitive or difficult stocks.
Change crease blades	Set the currently installed creasing / perforation tools.
Export files to USB	Export the machine's gathered data.
Import jobs from USB	Import job settings.
Units [mm/in]	Toggles between millimeters (mm) and inches (mm).
Language	Cycles through all available user interface languages.
Software version	Displays currently installed software version.
Service mode	For certified service technicians.

## Feeder Settings

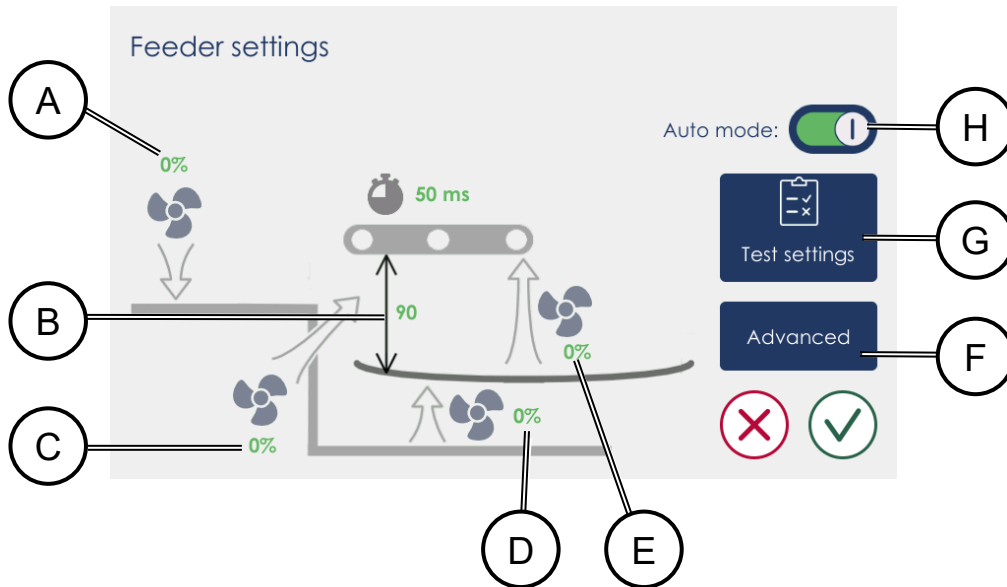

2

Element		Description
A	Registration fan	Adjusts the force with which the sheet is registered against the paper wall. Increase this if the sheets exit the feeder in an inconsistent orientation. Thinner sheets can be damaged (over-registered) if this value is set too high.
B	Paper density	Paper density is a value measured by the separated paper (SP) sensor. A higher value means more sheets are floated and the unfloatable pile is closer to the vacuum belts.
C	Separation fan	The front separation fan (air knife) floats the top sheets in the pile. Insufficient separation air can result in frequent misfeeds, while excessive air-flow can float too many sheets and result in double feeds.
D	Side float fan	The side fan can be used to add additional air for media that is difficult to separate with the front fan only. Excessive side float air can cause issues with registration.
E	Vacuum fan	Vacuum fan controls the force with which the top sheet in the pile is pulled in contact with the feed belts. Insufficient vacuum can result in frequent misfeeds, while excessive vacuum can pick up several sheets and result in double feeds.
F	Advanced	Press this button to access the advanced sub-menu. This sub-menu is described in the next page of this manual.
G	Test settings	This button allows the operator to start all feeder fans to check if
H	AUTO settings	Toggles automatic feeder mode. In AUTO mode feeder settings are calculated automatically depending on paper size and weight. In most cases AUTO settings will provide optimum feeding performance. Switching AUTO settings off allows the operator to make adjustments to fans.

## Feeder Settings - advanced

2

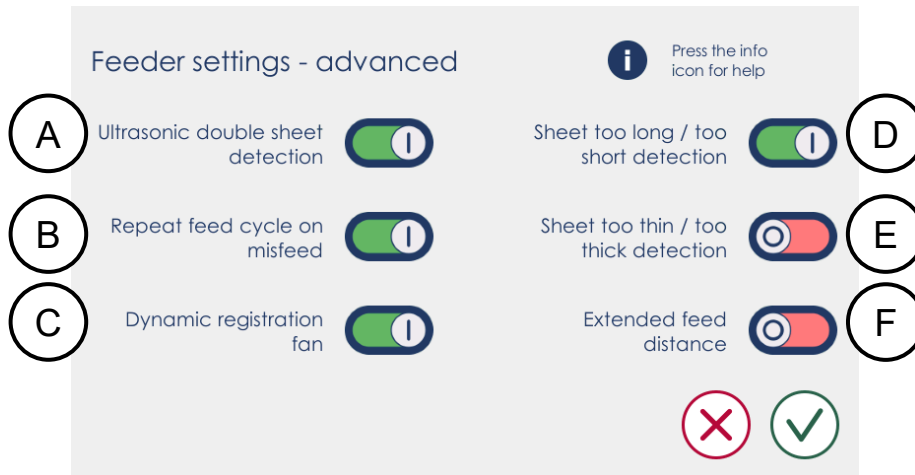

Element		Description
A	Ultrasonic double sheet detection ON/OFF	On by default. Can be switched off if the double sheet detector is giving incorrect readings, for example, on laminated stock.
B	Repeat cycle on misfeed ON/OFF	On by default. In case the feeder fails to pick up a sheet it will try again. Can be switched off if this damages sensitive media.
C	Dynamic registration fan ON/OFF	On by default. Adjusts registration fan speed during cycle the ensure long and thin sheets are not deformed in the feeder when they are stopped for creasing in the folder.
D	Sheet too long / too short detection ON/OFF	Off by default. As each sheet is fed, the machine measures its length. If it does not match the paper size entered into the UI, an error message will be displayed, and the process will be terminated.
E	Sheet too thin / too thick detection ON/OFF	Off by default. The thickness of each sheet will be measured by the machine using an ultrasonic double sheet sensor. If it does not match the paper thickness entered into the UI, the process will be aborted. <i>NOTE: This is not the same as double sheet detection. The detection of double sheets counts the number of surfaces.</i>
F	Extended feed distance ON/OFF	Off by default. Increases the distance a sheet is fed forward by vacuum belts. This may reduce the number of misfeeds on some stock. This may also cause poor registration.

## Clear Jams

Use this screen to jog rollers and tools to help with removing paper jams in the machine.

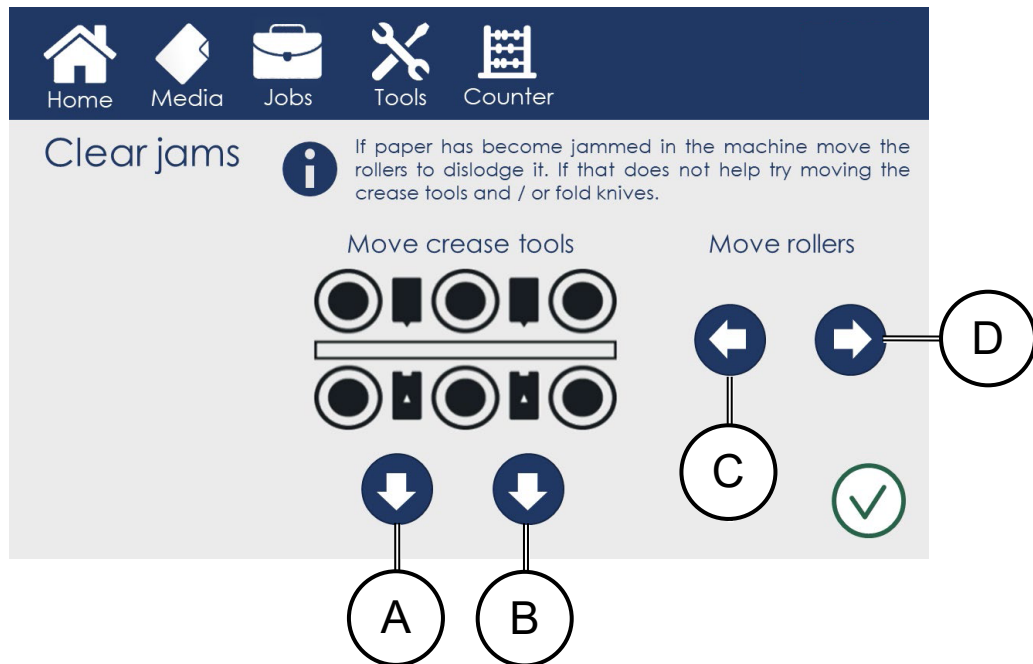

Element		Description
A	Open creaser 2	Opens the crease tool in case it has remained closed after a paper jam.
B	Open creaser 1	Opens the crease tool in case it has remained closed after a paper jam.  <b>NOTE:</b> <i>This button is greyed out if creaser 1 is not installed.</i>
C	Move rollers in process direction	Move rollers in the process direction in short bursts.
D	Move rollers against process direction	Move rollers against the process direction in short bursts.

## Change Crease Blades

When replacing creasing blades choose the currently installed creasing blades on this screen.

2

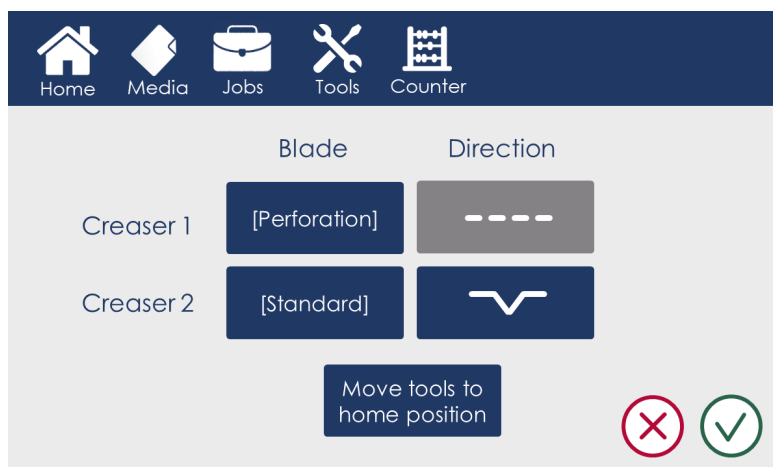

Element	Description
Blade buttons	Choose the type of blade currently installed in each creaser: [Standard], [Narrow], [Extra Narrow] or [Perforation]. Based on this setting machine parameters will be adjusted to suit the blade.
Direction buttons	Set the creasing direction (up or down) of each creaser. <b>NOTE:</b> <i>For the perforation blade a direction cannot be chosen.</i>
Home position button	Use this button to move the creasing mechanism to its home position. This helps when inserting / removing the blade set.

**NOTE:**

For blade set replacement instructions, see the “Replacing Blade Sets” section within this manual.

---

## Export files to USB

---

This function allows the user to copy logs from the machine to a USB drive. Sending logs to tech support might help with troubleshooting a jam or error condition.

2

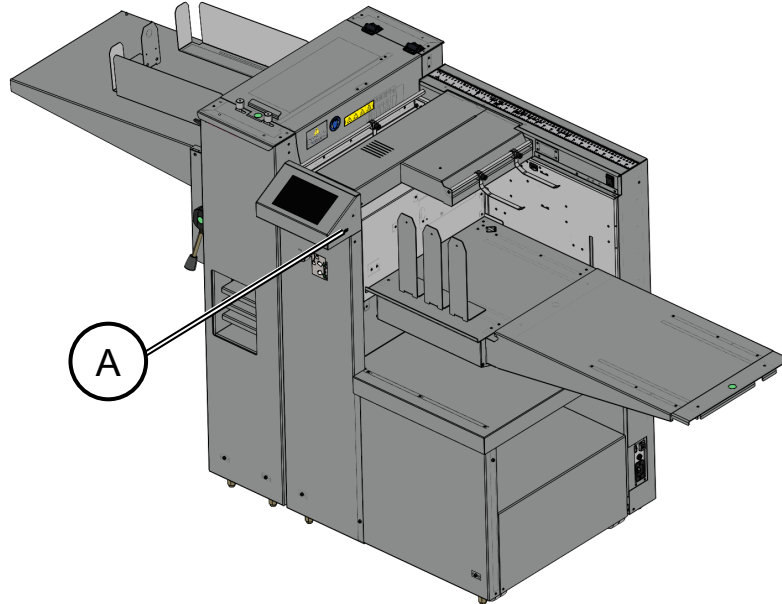

1. With the machine powered on plug in an empty USB stick in the USB port [A] on the right side of the user interface.

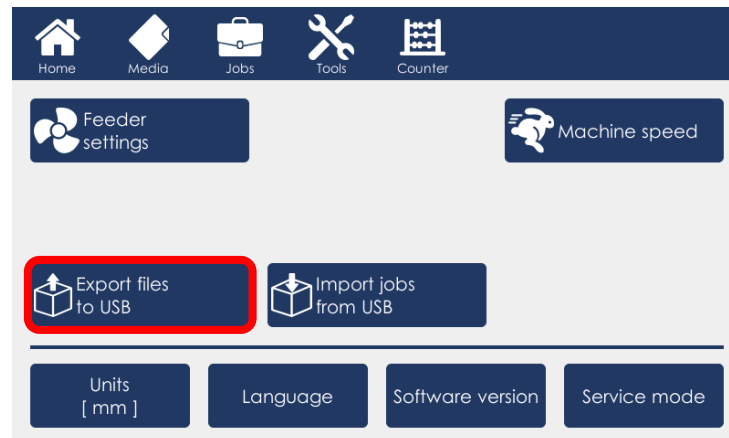

2. In Tools menu press [Export files to USB].
3. Wait until the export process is finished and remove the USB stick.
4. There will now be a folder named "device\_files" on the USB stick. Send the contents of this folder to Technical Support for analysis.

---

## Import jobs from USB

---

The operator can use this function to copy jobs from one machine to another in order to match customized job settings across multiple systems.

2

1. Firstly, Export data to USB from machine with preferred job settings (See section "Export files to USB").

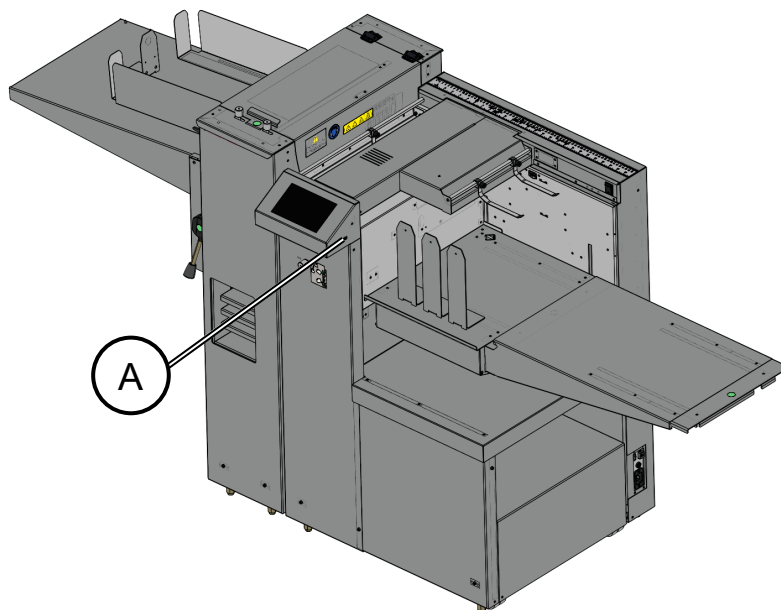

2. With the target machine turned on, insert a USB stick containing the data from the other machine into the USB port [A].

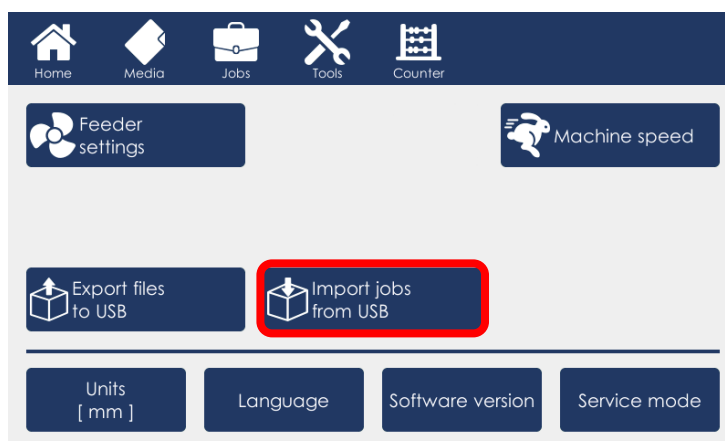

3. In Tools menu press [Import jobs from USB].
4. Wait until the import process is finished and remove the USB stick.
5. You will find imported jobs in Jobs menu; To load them see Section "Saving and Loading Jobs".

---

## Checking the Installed Software

---

1. To check currently installed machine software version, go to Tools -> Software version

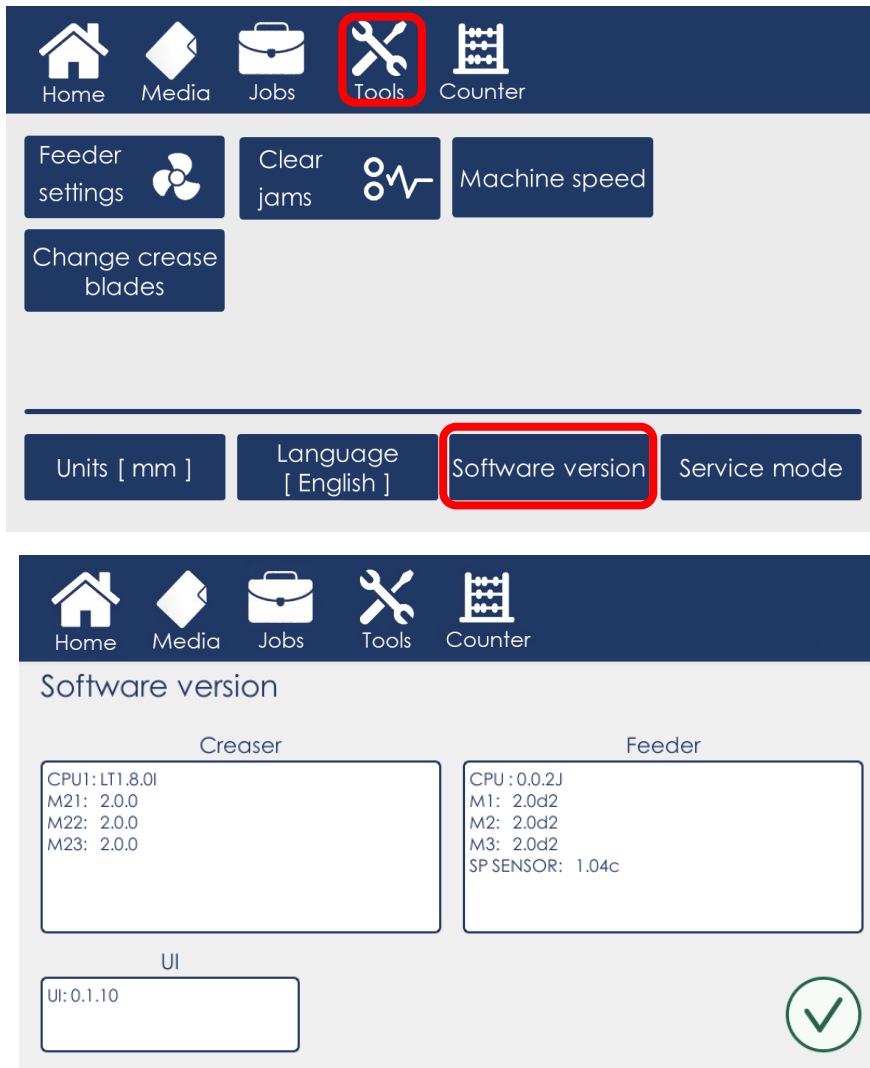

2

---

# 3 Troubleshooting

## Misfeeds / Jams

---

### General

---

3

If a misfeed or a jam condition should occur, it is indicated on the machine display. A message with the jam description, error code and approximate jam location is displayed.

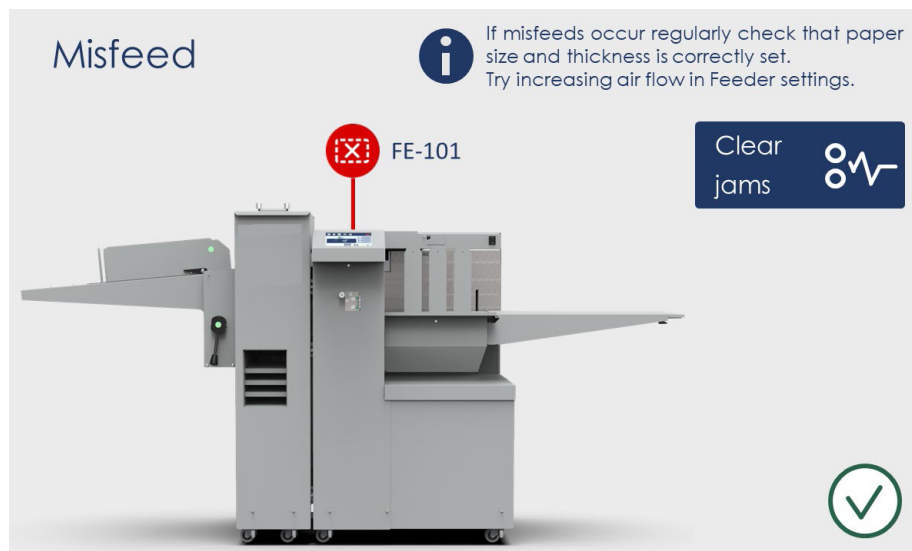

---

### Misfeed / Jam in the Feeder

---

1. Inspect the feed belt area for misfed sheets.
2. Inspect the registration area for misfed sheets.
3. If the sheet has been damaged, discard it. Otherwise, reposition it back on the lift.
4. Once the area has been cleared press the green tick mark on the screen.

---

### Misfeed / Jam in the Creaser

---

1. Click Clear jams on the jam screen or go to Tools and click Clear jams.
2. Open the top cover and inspect the area. If possible, remove the jammed sheet. Removing the rotary tool carrier and creasing blade(s) may help accessing the sheet.
3. If not, close the top cover and use the controls on the screen to jog the rollers to help with removing the sheet.
4. Once the area has been cleared, re-insert the rotary tool carrier and close the top cover. Press the green tick mark on the screen.

---

# Fault Codes

---

## General

---

When there is a misfeed or a fault condition in this machine, a message and a fault code will be displayed on the screen. Some fault codes may be rectified by the operator, while others may only be rectified by a certified service technician.

3

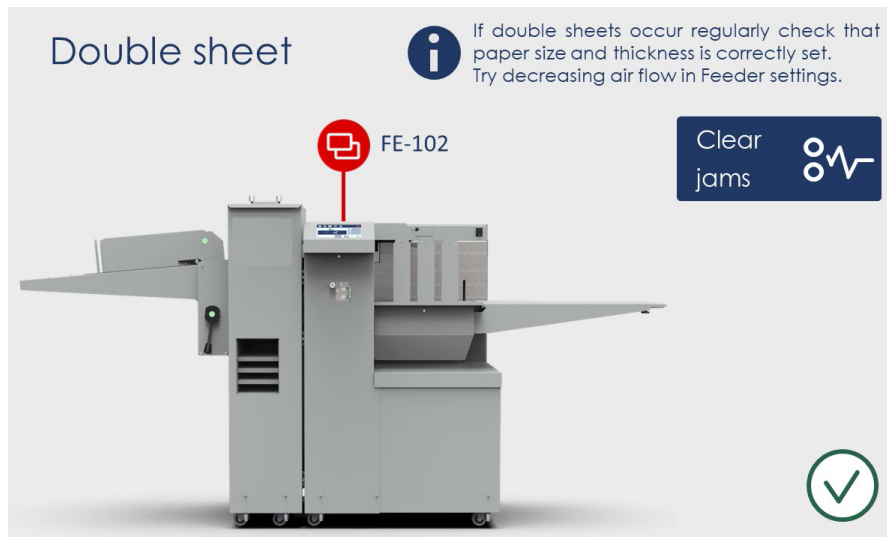

 **NOTE:**

*Clicking on the fault code will open a short description of the issue.*

To address fault codes other than those specified below, remove any paper in the paper path and power the system off and on again. If the fault code persists, contact a certified service technician.

List of fault codes that can be rectified by the operator:

- FE-101 – Misfeed
- FE-102 – Double sheet
- FE-103 – Sheet too long
- FE-104 – Sheet too short
- FE-106 – Out of paper
- FE-108 – Paper table overloaded
- FE-109 – Too much paper
- FE-112 – Double sheet detector (DSD) blocked
- FE-113 – Table extension removed during cycle
- FE-114 – Table extension added during cycle
- CR-201 – Sheet late from feeder output sensor Q7 to creaser input sensor Q20
- CR-202 – Creaser input sensor Q20 blocked
- CR-205 – Creaser 1 home sensor Q21 not activated
- CR-206 – Creaser 2 home sensor Q22 not activated
- CR-207 – Sheet late from creaser input sensor Q20 to creaser output sensor Q25
- CR-208 – Creaser output sensor Q25 blocked
- CR-209 – Clean creaser input sensor Q20

---



---

## List of Fault Codes

---



---



---

### FE-101 – Misfeed

---

This code is displayed if the ultrasonic double sheet detector (US DSD) Q10 was not activated in time after the start of the feed cycle. This means that the sheet has failed to exit the feeder table area.

#### Actions:

- Remove the jammed sheet (if any) from underneath the vacuum belts. If the sheet is damaged, discard it.
- Check the paper path for any obstructions or debris.
- Check that the paper loaded in the feeder matches the parameters (size and thickness) set in the UI.
- Fan the paper stack to ensure sheets are not stuck together and there is no excessive buildup of static electricity.
- Check that feeder magnetic side guides do not stop the sheet from freely exiting the feeder.
- If frequent misfeeds keep occurring after carrying out the above actions:
  - Check that the sheet can freely pass between the separation pads and the vacuum belts.
  - Turn off feeder AUTO settings and increase one or more of the following parameters: paper density, vacuum fan, separation fan.



#### NOTE:

See the “Feeder Settings” section of this manual for instructions on how to do this.

---

### FE-102 – Double sheet

---

This code is displayed when the ultrasonic double sheet detector (US DSD) Q10 has detected two or more overlapping sheets exiting the feeder at the same time.

#### Actions:

- Remove the jammed sheets from underneath the vacuum belts. If the sheets are damaged, discard them.
- Check the paper path for any obstructions or debris.
- Check that the paper loaded in the feeder matches the parameters (size and thickness) set in the UI.
- Fan the paper stack to ensure sheets are not stuck together and there is no excessive buildup of static electricity.
- If frequent double feeds keep occurring after carrying out the above actions:
  - Turn off feeder AUTO settings and increase one or more of the following parameters: paper density, vacuum fan, separation fan.
  - If using laminated paper or other multi-layered stock, switch off the US DSD.



#### NOTE:

See the “Feeder Settings” section of this manual for instructions on how to do this.

---

**FE-103 – Sheet too long**

---

When a sheet exits the feeder the ultrasonic double sheet detector (US DSD) Q10 measures its length to ensure the sheet matches machine settings. Error code FE-103 is displayed if the sensor Q10 is covered longer than expected. This can be either because the sheet is too long or because there is insufficient grip on the registration belts and the sheet cannot be fed forward.

**Actions:**

- Remove the jammed sheet from underneath the vacuum belts. If the sheet is damaged, discard it.
- Check the paper path for any obstructions or debris.
- Check that all sheets in the stack are the same length.
- Check that the paper loaded in the feeder matches the parameters (size and thickness) set in the UI.
- Fan the paper stack to ensure sheets are not stuck together and there is no excessive buildup of static electricity.
- Check that feeder magnetic side guides do not stop the sheet from freely exiting the feeder.

---

**FE-104 – Sheet too short**

---

When a sheet exits the feeder the ultrasonic double sheet detector (US DSD) Q10 measures its length to ensure the sheet matches machine settings. Error code FE-104 is displayed if the sensor Q10 is covered for less time than expected.

**Actions:**

- Remove the jammed sheet (if any) from underneath the vacuum belts. If the sheet is damaged, discard it.
- Check the paper path for any obstructions or debris.
- Check that all sheets in the stack are the same length.
- Check that the paper loaded in the feeder matches the parameters (size and thickness) set in the UI.
- Fan the paper stack to ensure sheets are not stuck together and there is no excessive buildup of static electricity.

---

**FE-106 – Out of paper**

---

Table empty sensor Q11 checks if paper is present on the table during the feed cycle. If no paper is detected, the machine stops the cycle and displays code FE-106. In most cases this is part of normal operation and is not a cause for concern.

**Actions:**

- Load more paper and continue the cycle.
- If there is paper on the table, but the error persists, clean the table empty sensor Q11. If the problem persists after that, contact service.

---

### **FE-108 – Paper table overloaded**

---

In order to stop paper table movement in case it is overloaded paper stack height sensor Q4 measures the amount of paper on the table when feed cycle starts. If the media used is longer than 700 mm (27.6”) the permitted paper stack height is limited to 100 mm (3.9”). If this height is exceeded the machine displays error code FE-108.

#### **Actions:**

- Check that the paper loaded in the feeder matches the parameters (size and thickness) set in the UI.
- Remove some of the paper stack from the feeder table.
- If the is paper stack is below the lower stack height marker on the paper wall, but the error persists, clean the paper stack height sensor Q4. If the problem persists after that, contact service.

---

### **FE-109 – Too much paper**

---

In order to stop paper table movement in case it is overloaded paper stack height sensor Q4 measures the amount of paper on the table when feed cycle starts. If the media used is shorter than 700 mm (27.6”) the permitted paper stack height is limited to 200 mm (7.9”). If this height is exceeded the machine displays error code FE-109.

#### **Actions:**

- Remove some of the paper stack from the feeder table.
- If the is paper stack is below the higher stack height marker on the paper wall, but the error persists, clean the paper stack height sensor Q4. If the problem persists after that, contact service.

---

### **FE-112 – Double sheet detector (DSD) blocked**

---

When starting the feed cycle each sensor is automatically checked for obstructions. Error code FE-112 is shown if the ultrasonic double sheet detector (US DSD) Q10 is blocked during cycle start.

#### **Actions:**

- Remove any jammed sheets from the paper path. If the sheet is damaged, discard it.
- Check the paper path for any obstructions or debris.
- If there is nothing covering the sensor, but the problem persists, clean sensor Q10 using the sensor cleaning brush. If the problem persists after that, contact service.

---

### **FE-113 / FE114 Table extension removed / added during cycle**

---

Table extension was either removed or added during cycle.

#### **Actions:**

- Check that table extension is securely mounted.
- If problem persists, sensor Q3 might be not working as in-tended: please contact service.

---

**CR-201 – Sheet late from feeder output sensor Q10 to creaser input sensor Q20**

---

If the sheet takes more time than expected to cover the distance between feeder output sensor Q10 and creaser input sensor Q20, the machine displays error code CR-201. This means that the sheet has exited the feeder table area but has not entered the creaser in time.

**Actions:**

- Remove the jammed sheet (if any) from the registration area or underneath the vacuum belts. If the sheet is damaged, discard it.
- Check the paper path for any obstructions or debris.
- Check that the paper loaded in the feeder matches the parameters (size and thickness) set in the UI.
- Fan the paper stack to ensure sheets are not stuck together and there is no excessive buildup of static electricity.
- Check that feeder magnetic side guides do not stop the sheet from freely exiting the feeder.
- If this error keeps occurring after carrying out the above actions:
  - Check that the sheet can freely pass between the separation pads and the vacuum belts.
  - Turn off feeder AUTO settings and increase one or more of the following parameters: registration fan, vacuum fan.

**NOTE:**

See the “Feeder Settings” section of this manual for instructions on how to do this.

---

**CR-202 – Creaser input sensor Q20 blocked**

---

When a sheet enters the creaser the input sensor Q20 measures its length to ensure the sheet has not jammed. Error code CR-202 is displayed if the sensor Q20 is covered longer than expected. This can be either because the sheet is too long or because there is a jam in the creaser and the sheet cannot be fed forward.

**Actions:**

- Remove the jammed sheet from the creaser rollers. If the sheet is damaged, discard it.
- Check the paper path for any obstructions or debris.
- Check that crease tools are installed in the correct direction with the arrows pointing in the paper movement direction.
- Fan the paper stack to ensure sheets are not stuck together and there is no excessive buildup of static electricity.

---

### CR-205 – Creaser 1 home sensor Q21 not activated

---

To produce creases at the specified positions accurately the creaser mechanism needs to initialize by moving to its home position. Creaser 1 position is measured by home sensor Q21. If the creaser mechanism cannot reach its home position or if the sensor cannot detect it, the machine will display error code CR-205.

#### Actions:

- Check creaser 1 for any obstructions or debris that may stop it moving to its home position.
- Clean creaser 1 home sensor Q21 using the sensor cleaning brush.



#### NOTE:

See the “Maintaining Your Machine” section of this manual for instructions on how to clean this sensor.

---

### CR-206 – Creaser 2 home sensor Q22 not activated

---

To produce creases at the specified positions accurately the creaser mechanism needs to initialize by moving to its home position. Creaser 2 position is measured by home sensor Q22. If the creaser mechanism cannot reach its home position or if the sensor cannot detect it, the machine will display error code CR-206.

#### Actions:

- Check creaser 2 for any obstructions or debris that may stop it moving to its home position.
- Clean creaser 2 home sensor Q22 using the sensor cleaning brush.



#### NOTE:

See the “Maintaining Your Machine” section of this manual for instructions on how to clean this sensor.

---

### CR-207 – Sheet late from creaser input sensor Q20 to creaser output sensor Q25

---

If the sheet takes more time than expected to cover the distance between creaser input sensor Q20 and creaser output sensor Q25, the machine displays error code CR-207. This means that the sheet has exited the feeder and entered the creaser but has not exited the creaser in time.

#### Actions:

- Remove the jammed sheet from the creaser rollers. If the sheet is damaged, discard it.
- Check the paper path for any obstructions or debris.
- Check that crease tools are installed in the correct direction with the arrows pointing in the paper movement direction.
- Check whether the height adjustable stacker is full. If it is, empty the stacker.
- Change stacker height.
- Make sure that stacker’s side guides are not too tight.
- Change machine speed (see “tools” section).

- 
- Fan the paper stack to ensure sheets are not stuck together and there is no excessive buildup of static electricity.

---

### **CR-208 – Creaser output sensor Q25 blocked**

---

Creaser output sensor Q25 monitors the sheet as it exits the machine. If the sensor is not uncovered in time, error CR-208 will be displayed. This means either that the sheet has failed to exit the machine or that the stacker is full.

**Actions:**

- Check whether the height adjustable stacker is full. If it is, empty the stacker.
- Remove the jammed sheet (if any) from the creaser rollers. If the sheet is damaged, discard it.
- Check the paper path for any obstructions or debris.

---

### **CR-209 – Clean creaser input sensor Q20**

---

Creaser input sensor Q20 automatically calibrates every time the machine cycle is started. If the sensor cannot successfully complete its calibration routine, error CR-209 will be displayed.

**Actions:**

- Clean sensor Q20 using the sensor cleaning brush.
- If the problem persists, contact service.



**NOTE:**

See the “Maintaining Your Machine” section of this manual for instructions on how to clean this sensor.

# Accuracy Checks

## Module Alignment Check

3

This machine consists of a feeder module and a creaser module. The alignment between these modules is set at the factory. To check that the modules have not become misaligned during shipping and handling carry out the following procedure:

1. With the machine powered off open the creaser top cover.
2. Take a stiff sheet of paper [A] and slide it against the registration wall [B].
3. Slide the sheet forwards until it comes in contact with creaser rollers. Check if both corners [C] of the sheet enter the rollers at the same time. Make sure that during this check the sheet remains parallel to the registration wall.

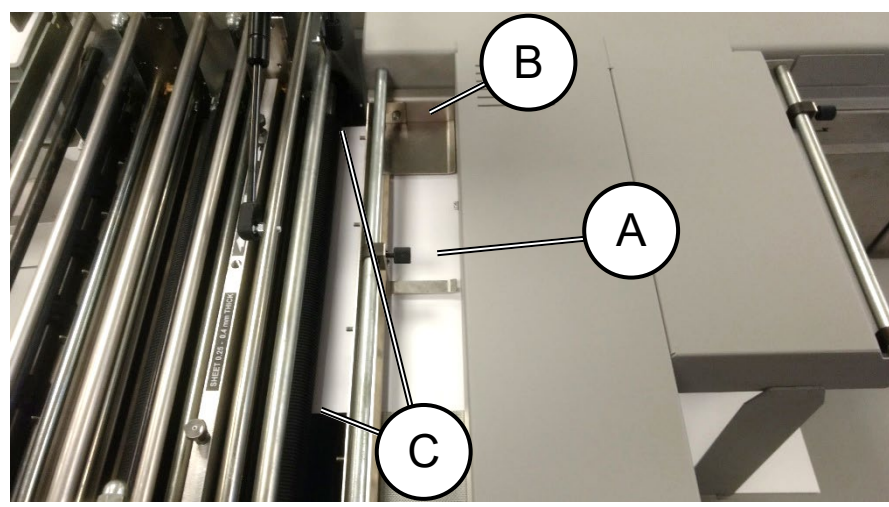

4. If the modules are visibly out of alignment, follow the realignment procedure in the Service Manual.
5. If the modules appear aligned, remove the sheet of paper, close the top cover and power on the machine.
6. Run a proof sheet with a single crease and inspect the output.

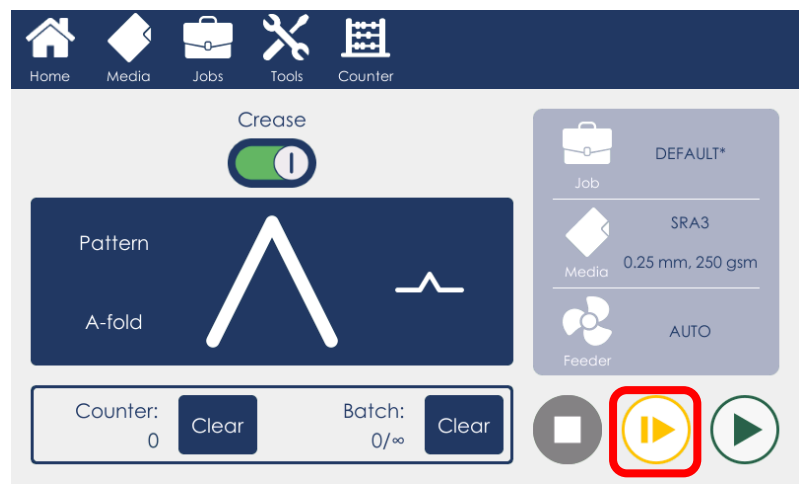

7. If the crease is skew, adjustment is necessary.

 NOTE:

Wrong crease positions are marked in red, correct crease position is marked in green.

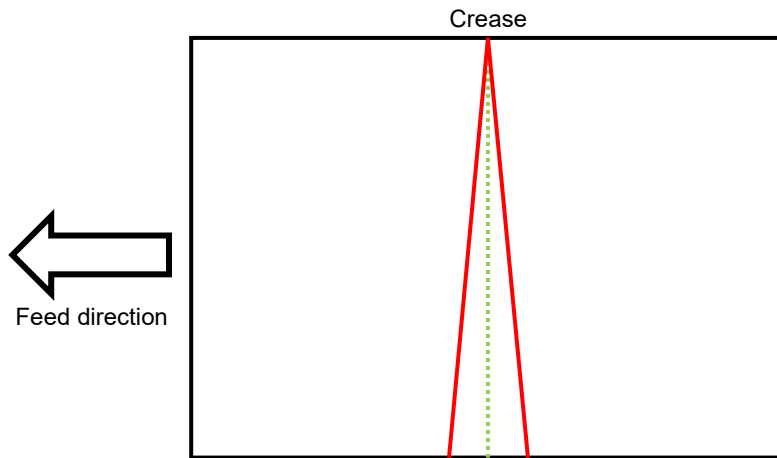

8. To adjust crease skew, loosen the crease adjustment knob by rotating it counterclockwise.

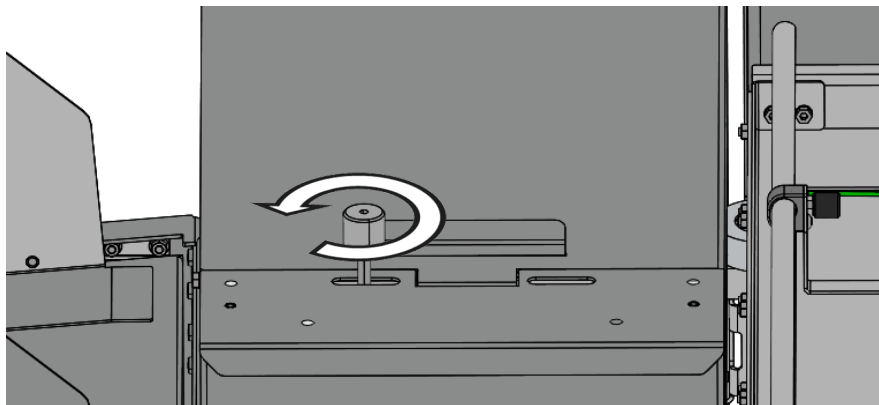

9. Move the knob slightly, either to the left or to the right depending on the direction of the crease skew.

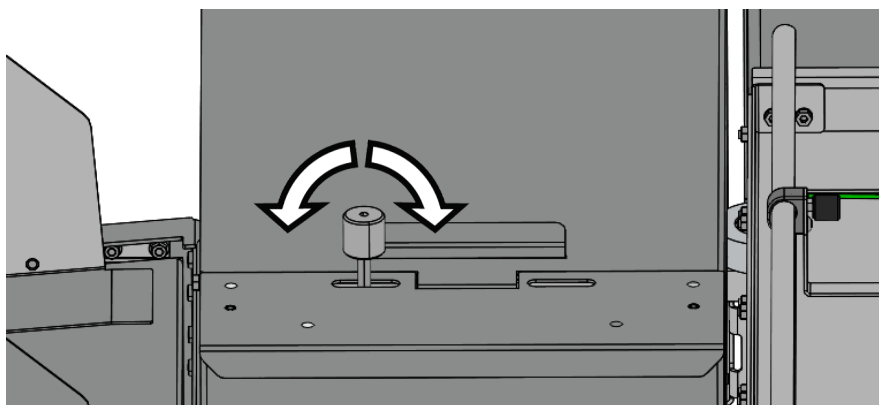

10. Rotate the knob clockwise to secure it.  
11. Run another proof sheet to check if the crease is now perpendicular to sheet edge.  
Repeat steps 6 to 10 if necessary.

---

## Separation Pad Check

---

Rubber separation pads are used in the feeder to prevent several sheets from exiting the feeder table area at the same time. Separation pad position is set at the factory. If frequent misfeeds or double sheets occur the separation pad position may need to be adjusted by the following procedure:

3

1. Use a steel ruler or several stiff sheets of paper to check the gap between the separation pads [B] and the lowest point of the vacuum belt roller is even and around 1 mm (0.04"). If it is, the cause of misfeeds or double feeds is likely feeder parameters.
2. If not, use the included 2.5 mm hex key to loosen 2x bolts [A].
3. The separation pads [B] should now freely move up and down.
4. Use a steel ruler or several stiff sheets of paper to set the gap between the separation pads [B] and the vacuum belts to 1 mm (0.04").
5. Tighten the bolts [A].

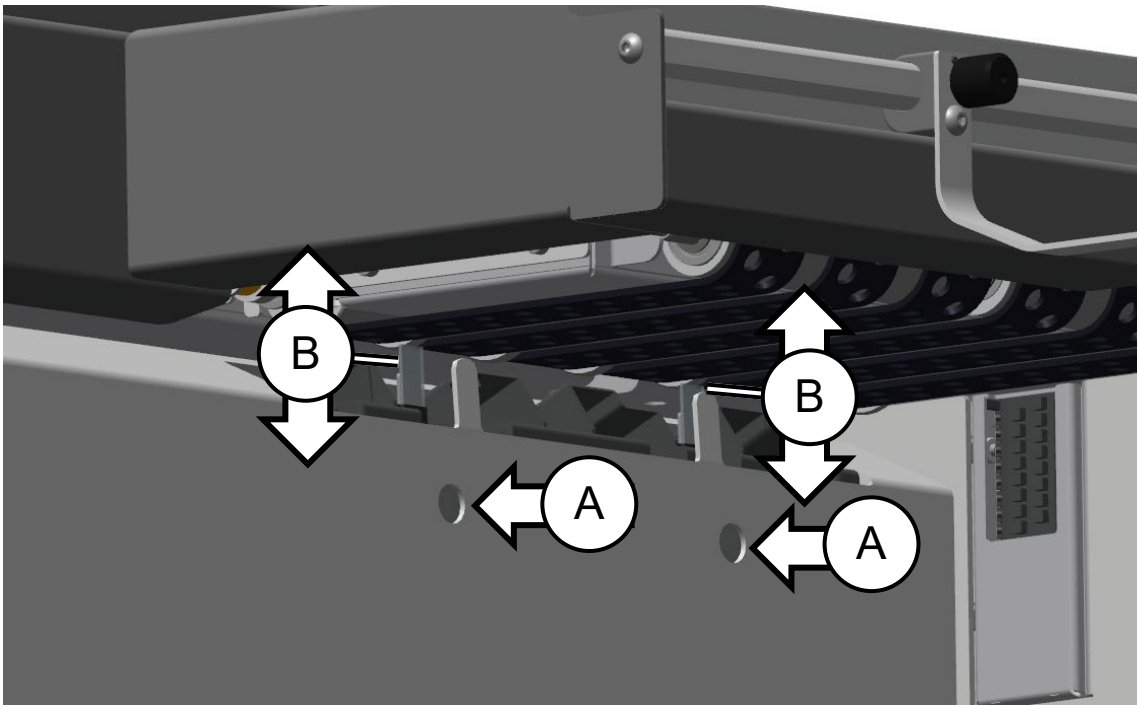

---

## Creaser Calibration Check

---

The creasing position is accurately calibrated at the factory. To check that the machine has not lost its calibration during shipping and handling carry out the following procedure:

1. Run a proof sheet with a half fold pattern.

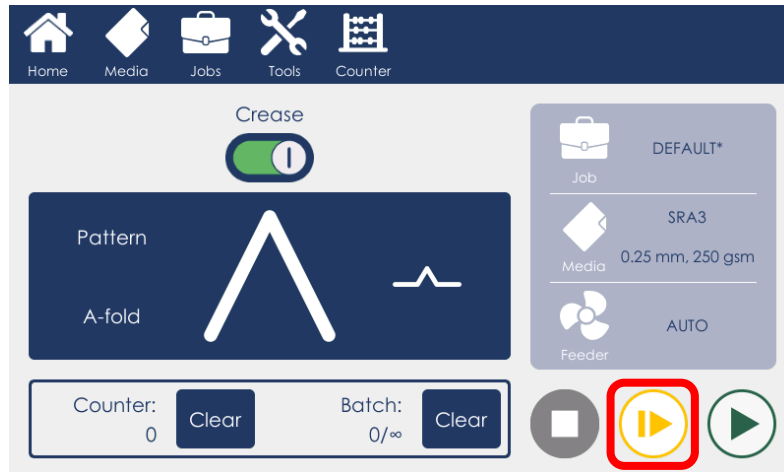

3

2. Measure the distance between the lead edge of the paper and the crease. The measurement should equal to the paper length divided by 2.

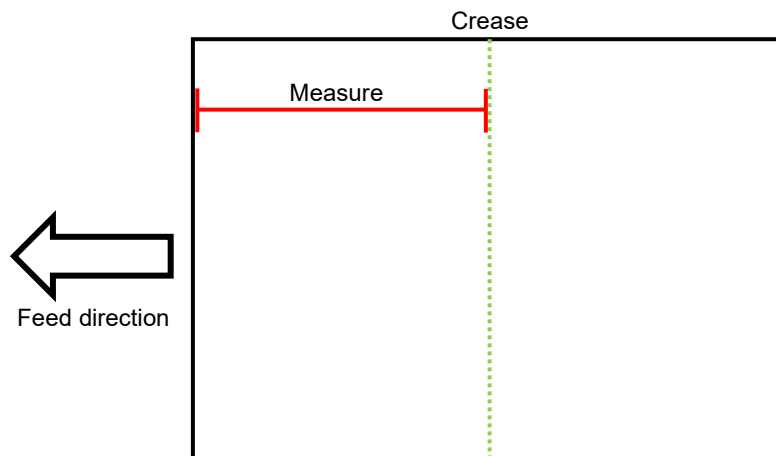

3. If the measurement is not within the machine tolerance ( $\pm 0.25$  mm /  $\pm 0.001$ " ) contact your Dealer to perform machine re-calibration.

---

## How to Get Support

### CAUTION:

*Never attempt any maintenance that is not specifically described in this documentation. Please contact your Dealer for authorized servicing.*

3

If you encounter problems running this machine and you cannot solve them by following the advice given in the Troubleshooting section of this manual, please contact your authorized Dealer for further support.

When contacting your Dealer please provide as much information as possible about the job you are attempting to run, and the problems you encounter.

- What machine do you have?
  - You can find the model name and serial number of your machine on the nameplate in the feeder shelf.
  - You can find the software version your machine by following the instructions in “Checking the installed Software” section of this manual.
- What job are you running?
  - Paper size, thickness and weight (gsm / lbs.)
  - Paper finish – plain / coated / silky / textured
  - Pre-set / custom job
  - Creasing / perforation
- What is the issue?
  - Feeding problems
  - Creasing problems
  - Fault codes displayed by the machine
  - What have you tried already to resolve the issue?

Page intentionally blank.

---

# 4 Remarks

## Do's and Don'ts

4

- Always follow all warnings marked on, or supplied with, the equipment.
- Always exercise care in moving or relocating the equipment.

 **CAUTION:**

*Unplug the power cord from the wall outlet and the machine before you move or relocate the equipment.*

- Do not remove covers or guards that are fastened with screws.
- Do not override or bypass electrical or mechanical interlock devices.
- Do not operate this equipment if you notice unusual noises or odors. Disconnect the power cord from the power source and call a certified service technician to correct the problem.

 **WARNING**

**This is a Class A product. In a domestic environment this product may cause radio interference in which case the user may be required to take adequate measures.**

 **NOTE:**

*The domestic environment is an environment where the use of broadcast radio and television receivers may be expected within a distance of 10 m of the apparatus concerned.*

- Do not switch off the power while the machine is running. Make sure the machine cycle has ended.
- Do not open covers while the machine is running.
- Do not move the machine while the machine is running.
- Do not make arbitrary changes to the machine.

---

# Where to Put Your Machine

---

## Machine Environment

---

- Always locate the equipment on a solid support surface with adequate strength for the weight of the machine.
- Always keep magnets and all devices with strong magnetic fields away from the machine.
- If the place of installation is air-conditioned or heated, do not place the machine where it will be:
  - Directly exposed to cool air from an air-conditioner
  - Subjected to sudden temperature changes
  - Directly exposed to heat from a heater

4

---

## Power Connection

---

- **Always** connect the equipment to a properly grounded power source. If in doubt, have the power source checked by a qualified electrician.

 **WARNING**

**Improper grounding of the equipment can result in electrical shock.**

- **Never** connect the machine to a power source that lacks a ground connection terminal. A missing ground will cause damage to electronics and cause machine malfunctions.

## Access to Machine

Place the machine near a power source, providing clearance as shown.

4

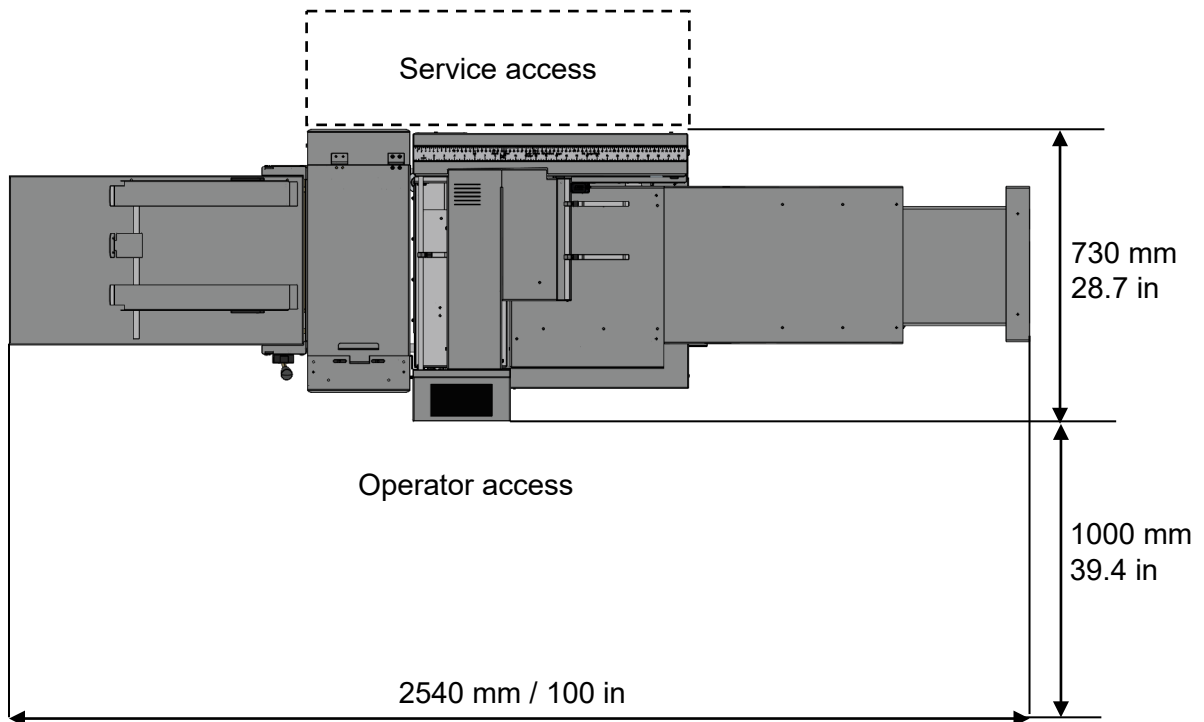
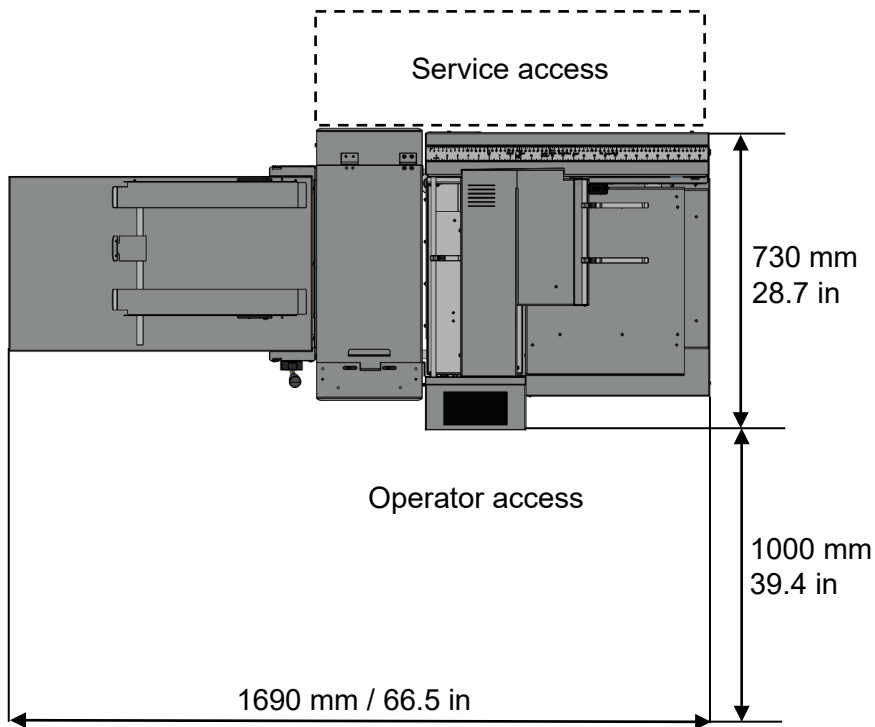

### Actual Product Dimensions (For Reference)

Product	Length	Width	Height
Atlas C150	1690 mm / 66.5 in	730 mm / 28.7 in	1160 mm / 45.7 in
Atlas C150 with feeder table fully extended	2540 mm / 100 in	730 mm / 28.7 in	1160 mm / 45.7 in

---

## Maintaining Your Machine

### CAUTION:

Never attempt any maintenance that is not specifically described in this documentation. Please contact your Dealer for authorized servicing.

---

### Recommended Weekly Operator Maintenance

---

4

To maintain the accuracy and reliability of this machine it is recommended to carry out the following maintenance on a weekly basis:

1. Power off the machine using the main power switch. Remove any remaining paper from the feeder table.
2. Wipe down the feeder table and other paper path surfaces.
3. Check feeder separator pads for damage or wear.
4. Clean vacuum belts and paper feed rollers from any paper or toner dust using the supplied roller cleaning brush [A].
5. Remove the rotary tool carrier to clean its rollers.
6. Remove and clean the creasing blade.

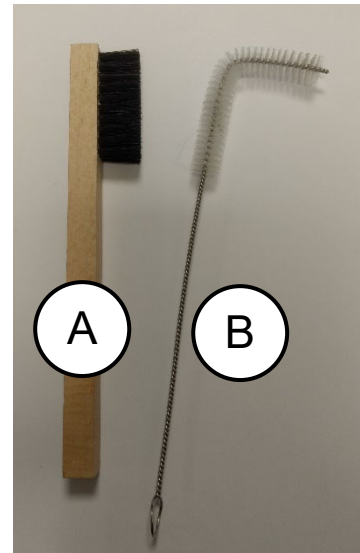

### NOTE:

For instructions on how to remove the creasing blade, see the “Replacing Blade Sets” section within this manual.

7. Clean all sensors using the supplied sensor cleaning brush [B] (see next page).
  - Table empty sensor Q11 [C]
  - Separated paper (SP) sensor Q12 [D]
  - Top down paper sensor Q4 [E]
  - Creaser input sensor Q20 [F]
  - Creaser home sensor(s) Q22 (Q21) [G]
  - Creaser output sensor Q25 [H]

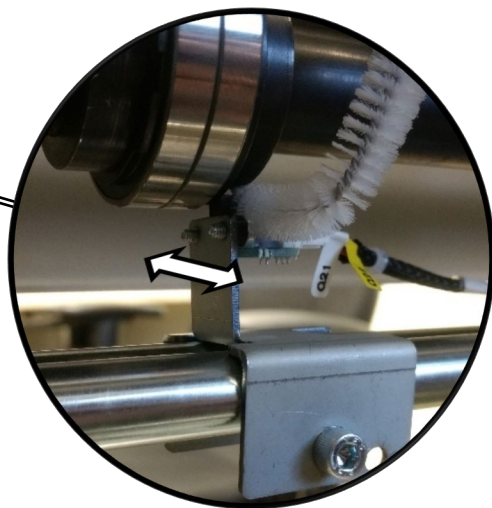
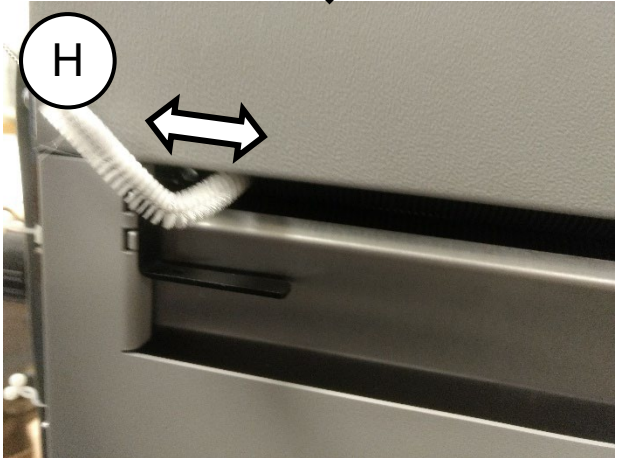
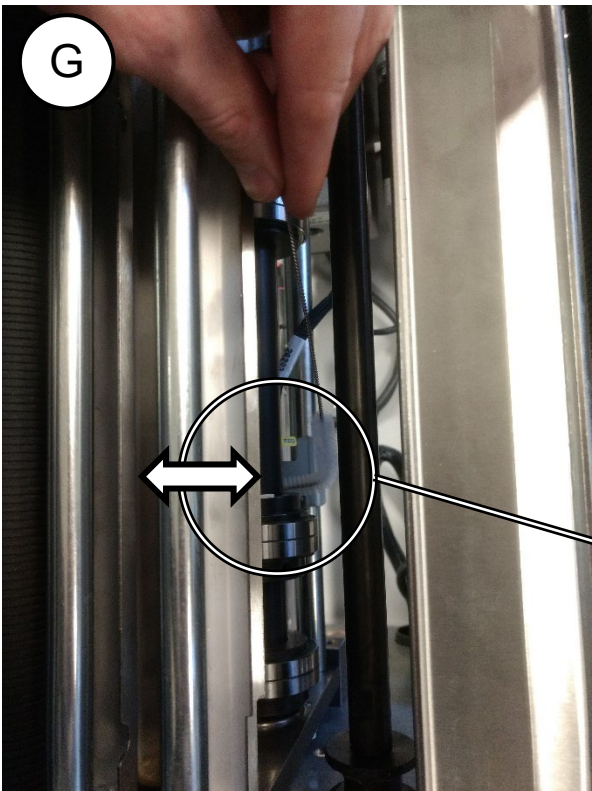
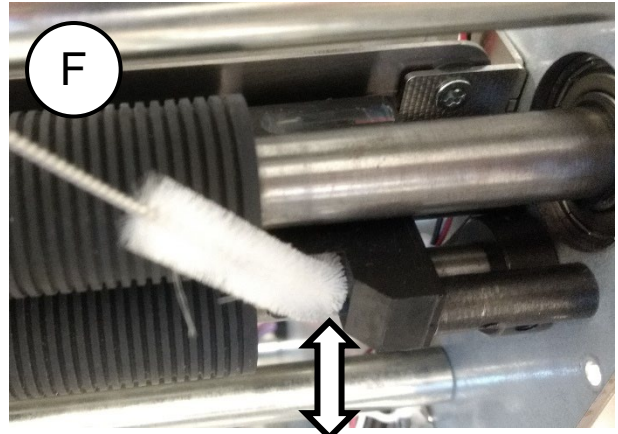
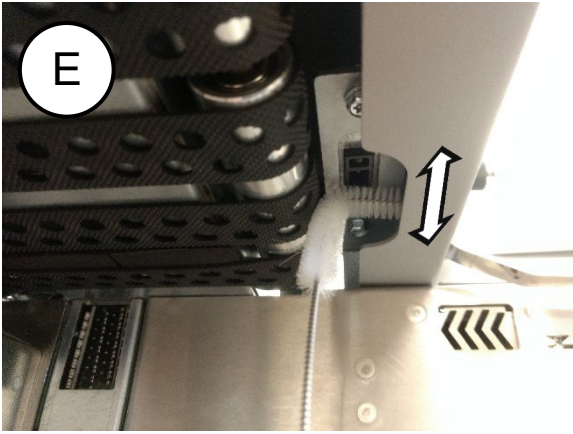
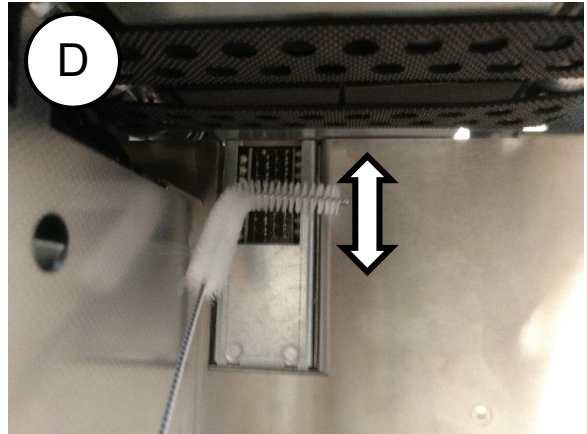
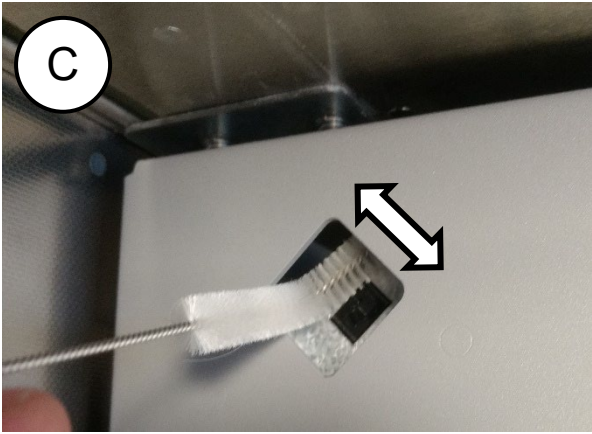

---

## Limitations of the Atlas C150

- The intended average monthly sheet volume for the Atlas C150 is 450k.
- Maximum hourly productivity of this machine is 8500 sheets. This is measured using 200 gsm A4 paper short edge feed with a single crease in the middle of the sheet using the first (optional) creaser.
- Paper quality affects the output quality of this machine. If the sheets entering this machine are not uniform and square, the output will vary accordingly.
- The Shut Down Rate (SDR) of this machine is 1/2000 feeds.
- Feeder paper capacity is limited to:
  - 200 mm (7.9") for sheets up to 700 mm (27.6") in length
  - 100 mm (3.9") for sheets longer than 700 mm (27.6")

# 5 Specifications

## Machine Specification

### General

5

Power source	Voltage: 100-240 V ac (tolerance -10/+6%) Current: 8-4 A Frequency: 50/60 Hz
Power consumption	Standby: 55W Maximum: 750 W
Operating temperature	10-30 °C (50-86 °F)
Humidity	30-80 % RH
Sound emissions	80 dB

### Physical Characteristics

Product	Length	Width	Height	Weight
Atlas C150	1690 mm (66.5")	730 mm (28.7")	1160 mm (45.7")	250 kg (551 lbs)
Atlas C150 with table extension	2540 mm (100")	730 mm (28.7")	1160 mm (45.7")	250 kg (551 lbs)
Packaged	1200 mm (47.2")	800 mm (31.5")	1305 mm (51.4")	305 kg (672 lbs)

### Paper handling

Feeder module	
Max stack:	200 mm (100 mm for sheet lengths above 700 mm) 7.9" (3.9" for sheet lengths above 27.6")
Max paper size W x L:	385 x 700 mm (385 x 1300 mm with table extension) 15.2" x 27.6" (15.2" x 51" with table extension)
Min paper size W x L:	93 x 210 mm 3.7" x 8.3"
Max paper thickness:	0.4 mm (400 gsm) 0.0157"
Min paper thickness:	0.09 mm (80 gsm) 0.0035"
Max paper curl	±6 mm ±0.24"
Creaser module	
Minimum crease to crease distance	0.1 mm 0.004" * *It is recommended to place creases at a minimum distance of 1.5 mm / 0.06" from each other.
Creasing resolution	0.1 mm 0.004"
Stacker capacity	120 mm 4.7"
Stacker max paper size W x L	385 x 1040 mm 15.2" x 41"
Min crease distance from sheet leading edge	5 mm 0.2"

---

Min crease distance from sheet trailing edge
---

5 mm 0.2"
--------------

## Output Quality

Conditions:

- Paper size is assumed to be perfect
- Sheets are assumed to be perfectly 90°
- Tolerances are referring to deviations within one job

	A4 Letter	A3 Ledger
Crease position variation	$\pm 0.20 \text{ mm}$ $\pm 0.008''$	$\pm 0.20 \text{ mm}$ $\pm 0.008''$
Crease skew	$\pm 0.25 \text{ mm}$ $\pm 0.010''$	$\pm 0.40 \text{ mm}$ $\pm 0.016''$

### Quality definitions

Measurements refer to any crease position

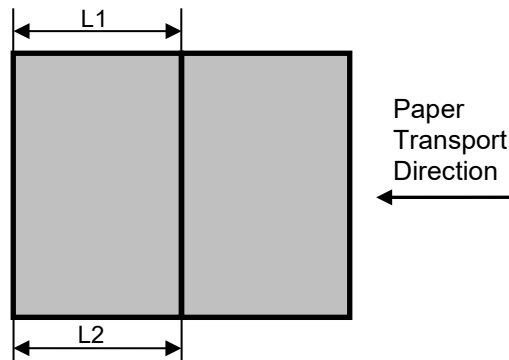

#### Crease position variation

Measurement  $(L1+L2) / 2$  from sheet to sheet

#### Crease skew

Measurement  $L1 - L2$